



REV 00
DATE: JAN 29, 2018

Avid Controls Inc.
41261 Park 290 Drive, Waller, TX 77484, USA
info@avidcontrolsinc.com
(+1) (281) 640-8600

AVID Controls Inc. pursues a policy of continuous product improvement and innovation. This may not be the latest revision of this publication and may not reflect all current product changes. Contact AVID Controls Inc. for the latest revision of this data sheet and information on other product enhancements.

Contents

1. Introduction	3
2. Safety Instructions	3
3. Disposal	3
4. Related Documents.....	4
5. Specifications	4
5.1 Electrical & Fan Specifications	4
5.2 Mechanical Specifications	5
5.3 Environmental Specifications.....	5
5.4 Power and Control Connections	6
6. Mechanical Installation	8
7. Fan Support Bracket.....	10
8. Installation & Commissioning.....	11
8.1 Commissioning	11
8.2 Cabling.....	11
9. Glossary of Terms	12
10. Contact Details for Sales, Service and Support.....	12
11. Document Revision History	12

AVID CONTROLS and the  logo are registered trademarks of Avid Controls Inc.

1. Introduction

- The 31V6900-10-A is manufactured by Avid Controls Inc. of Waller, Texas, USA under license from the General Electric Company.
- The MV3000 High Performance Fan system is used to cool Air Cooled DELTA power modules with one fan required per each DELTA module.
- The fan locates onto the upper cross rail. The inlet duct assembly provides the upper guide rail for the Air-Cooled DELTA. The fan housing is designed to be removed and/or replaced whilst leaving the inlet duct assembly in place.
- This fan is designed as a spares replacement for fans on existing GD and MV Delta installations. It should NOT be used on new installations.

2. Safety Instructions

- Care has been taken with the design of this product to ensure that it is safe. However, in common with all products of this type, misuse can result in injury or death. Therefore, it is very important that the instructions in this technical data sheet and the manual as well as on the product are observed during transportation, commissioning, operation, maintenance and disposal.
- This technical data sheet and the manual must be regarded as part of the product. It should be stored with the product and must be passed on to any subsequent owner or user.
- Local safety laws and regulations must always be observed.
- Persons working on the product must be suitably skilled and should have been trained in that work for these products.
- The product is a component designed for incorporation in installations, apparatus and machines.
- The product must not be used as a single item safety system. In applications where mal-operation of the product could cause danger, additional means must be used to prevent danger to persons.
- Product approvals and certifications will be invalidated if the product is transported, used or stored outside its ratings or if the instructions in the manual are not observed.
- In the European Union:
 - Products within the scope of the Low Voltage Directive, 2006/95/EC are CE marked.
 - The product complies with the essential protection requirements of the EMC directive 2004/108/EC, when installed and used as described in the manual.
 - The requirements of the EMC Directive should be established before any installation, apparatus or machine, which incorporates the product, is taken into service.
 - A machine must not be taken into service until the machine has been declared in conformity with the provisions of the Machinery (Safety) Directive, 2006/42/EC.

3. Disposal

- This equipment or any part of the equipment should be disposed of in accordance with the laws of the country of use.
- Modern high technology materials have been used in the manufacture of the equipment to ensure optimum performance. Care has been taken with the selection of these materials to minimize risks to health and safety. However, some materials require special consideration during the disposal.

4. Related Documents

- This module is one component out of a range of components used for the MVD3000 and PED drive system. This data sheet gives details specifically for the items listed at the start of this document.
- For additional information on the installation, commissioning, operation, maintenance and performance of the complete drive system, please refer to the following documents:
 - T1689EN, Technical Manual for MV3000 Air Cooled DELTA Drive System

5. Specifications

5.1 Electrical & Fan Specifications

Function	Specification
Nominal Input Voltage Range	400V AC RMS, Three Phase, $\pm 10\%$
Nominal Supply Frequency	50 / 60 Hz
Operating Current	1.35A / 1.9A
Starting Current	5.4A / 7.6A
Start Up Time	2 Seconds
Typical max. fan speed	2880 / 3320 RPM
Typical Airflow Characteristics	Approximately 900 m ³ /hour (525 CFM) at a pressure of 900 Pa (3.7 In H ₂ O)
Overall Efficiency	60.1%
Efficiency Grade N	73.8
Power Input	750W / 1250W

5.2 Mechanical Specifications

Function	Specification
Weight	56 lbs. (25.4 kg)
Physical Dimensions approx..	Height 20 in (502 mm) Width 9 in (236 mm) Depth 17 in (435 mm)

5.3 Environmental Specifications

Function	Specification
Operating	
Ambient air temperature range	0 to 50°C (32°F to 122°F)
Relative humidity	5 to 95 % (non-condensing)
Altitude	Normal operating altitude up to 1000 m above sea level. From 1000 m (3280 ft) to a maximum of 2000 m (6551 ft) derate by 7.3% per 1000 m (3280 ft).
Atmosphere	Pollution Degree 2 (IEC 61800-5-1 and IEC 60664-1) i.e. clean, free from dust, condensation and conductive or corrosive gases. If conductive pollution or condensation are expected (Pollution Degree 3), the High Performance Fan must be placed in an enclosure which achieves Pollution Degree 2 by: <ul style="list-style-type: none"> - excluding the conductive pollution e.g. by the use of filtered air; - preventing condensation e.g. by the use of anti-condensation heaters. In extreme environments dual circuit heat exchangers are recommended.
Atmospheric chemicals (max)	15 ppm H ₂ S 25 ppm NO ₂ 25 ppm SO ₂
Storage	
Temperature range	-25°C to +55°C (-13°F to 131°F)
Relative humidity	5 to 95 % (non-condensing)
Transport	
Temperature range	-25°C to +70°C (-13°F to 158°F)
Relative humidity	≤ 95 % (non-condensing)
Altitude	Will withstand air transport
Enclosure Ingress Protection	IP00 Not Protected, unit protected against accident contact only when installed as described in this instruction sheet. Unit must be mounted in an enclosure with restricted access.

5.4 Power and Control Connections

- The fan assembly has a single 9 way connector TB1 which is a two-way removable plug.
- Wire Size Limits: 0.5* - 1.5 mm² (20* - 16 AWG).
- Use consolidating crimp for smaller wires.
- The function of each connection is given below:

Fig.1. Connection Detail TB1

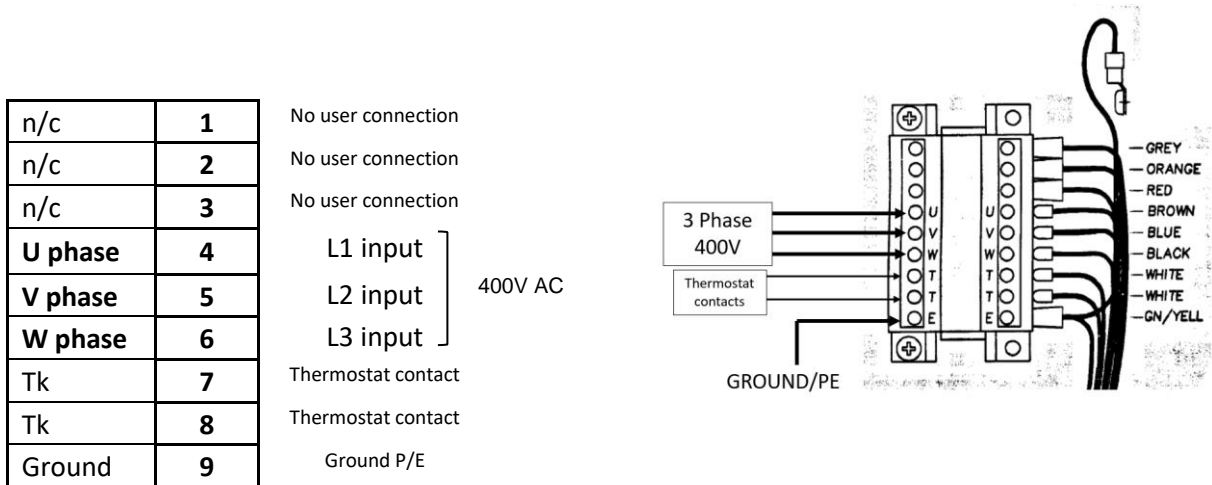

Thermostat contacts, normally closed, to be wired to control system input to remove power if motor overheats and provide warnings etc

WARNING

Failure to comply with the above instructions will result in damage to the equipment and present a safety hazard.

5.4.1 Motor Connections - details

The fan motor has 3 phase windings with each connection brought out to the terminal block. The normal configuration for this fan assembly is that the motor is connected in Star or Wye (Y) mode as shown below.

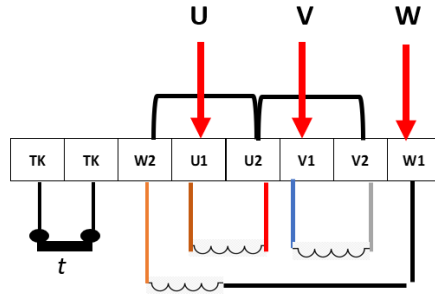

Normal Star/Wye Connection for 400V AC
as supplied

The windings are already connected in this mode via jumper links fitted by Avid. Alternative connection in Delta (Δ) mode is possible by re-wiring the terminal block as shown below.

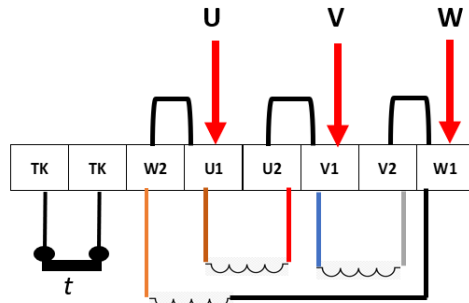

Alternative Connection – Delta Mode

Note that in this mode the fan will now operate on a 230V AC three phase supply.

WARNING

Do not apply 400V AC when configured in this mode as damage will occur.

6. Mechanical Installation

- Box Contents

The fan packing box contains one each of the following:

- High-Performance Fan 31V6900-10-A
- Fan Support Bracket 50Y9742/01
- M5 x 10 Taptite screw
- Data Sheet DTS-01357-ASY-A

WARNING

- **Ensure that access to rotating parts of fans is prevented.**
- **Air used to cool the product is unfiltered. Air ejected from the product may contain foreign particles. Air outlets should be arranged to deflect the air away from the eyes.**
- **The combined audible noise emitted by fans in an installation can be greater than 70dB(A), dependent on the air flow path. Measure the audible noise level in the installation. When the audible noise level exceeds 70dB(A), appropriate warning notices should be displayed.**

- The fan assembly is designed to locate onto the upper cross members of the DELTA mounting frame – refer to the Air Cooled DELTA manual T1689 for full installation details. One fan assembly must be fitted above each Air Cooled DELTA module with four M6 x 15 mm (9/16 in) hexagon headed bolts with plain and spring washers. The fan mounting flange should sit flat against the underside of the two top cross members with the bolts screwing into the threaded inserts in the cross members. Partly screw in the bolts first and then slot the fan into place using the key-holes in the mounting flange as shown in Figure 2 - Installing a Fan Box. Tighten the bolts fully.

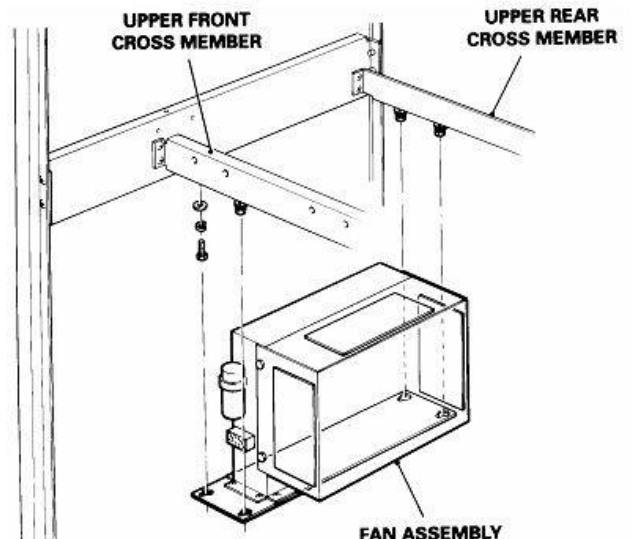

- The fans are heavy and may be awkward to lift into place, each fan may be split into two pieces. The fan duct fitted first, the main body of the fan housing then being added by pushing horizontally into the location tabs at the rear of the assembly and fixing by the two M6 bolts at the front. Care must be

taken to ensure that any wiring disconnected from the terminal block is correctly re-connected and not damaged during fan installation.

- Each fan has a choice of three air outlets; front, top or rear. These are selected by removing the appropriate cover and using this cover to block the unwanted outlet. To keep personnel from the main air and noise path it is recommended that the airflow outlet is through the top or rear of the drive enclosure.
- These fans are normally fitted at the top of the enclosure, outside of the normal accidental finger access range. If they are installed in a position where the fan is accessible, mechanical protection must be provided.
- The air outlet must not be obstructed and should preferably be ducted out of the control enclosure. Figure 3 - Fixing Centers on DELTA Cooling System for Ducting the Outlet shows the six fixing centers on each of the fan outlets for connecting a duct.

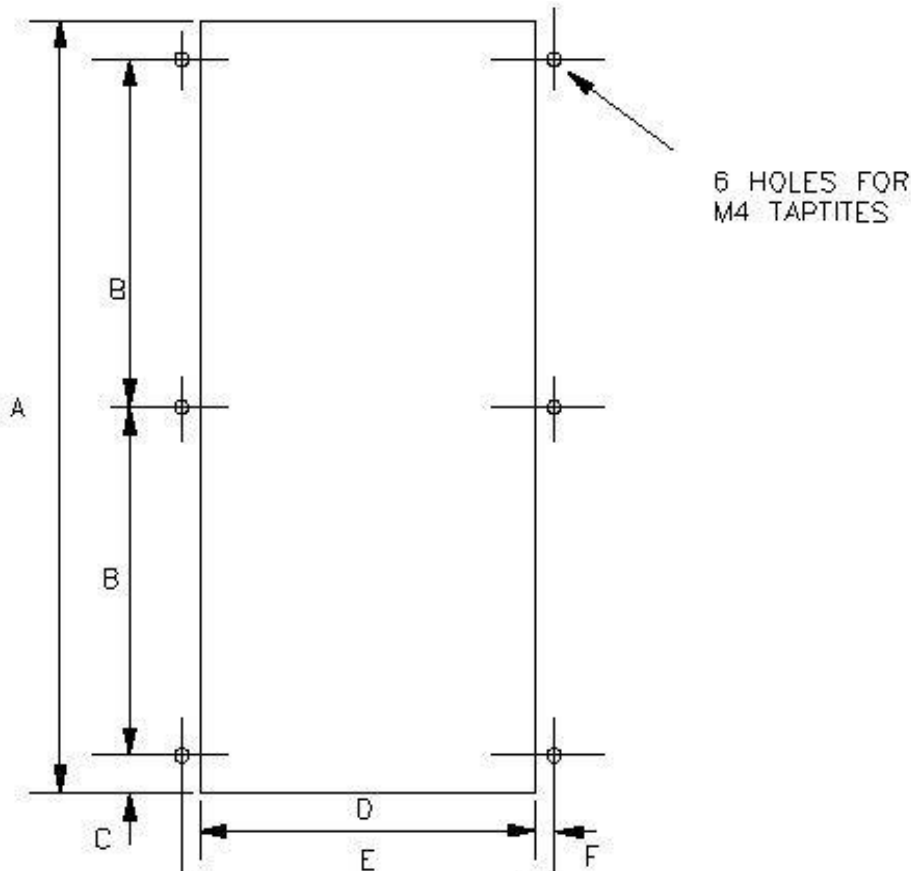

Figure 3 - Fixing Centers on DELTA Cooling System for Ducting the Outlet

7. Fan Support Bracket

- NOTE: The bracket (50Y9743/01) must be fitted to the cubicle to provide support for the high-performance fan.
- Failure to fit this bracket may cause mechanical damage.
- Each bracket should be secured to the Upper Rear Cross Member with an M5 x 10 mm pozi-headed Taptite screw.
- Shown in Figure 4 - Fitting of fan support bracket (50Y9743/01).

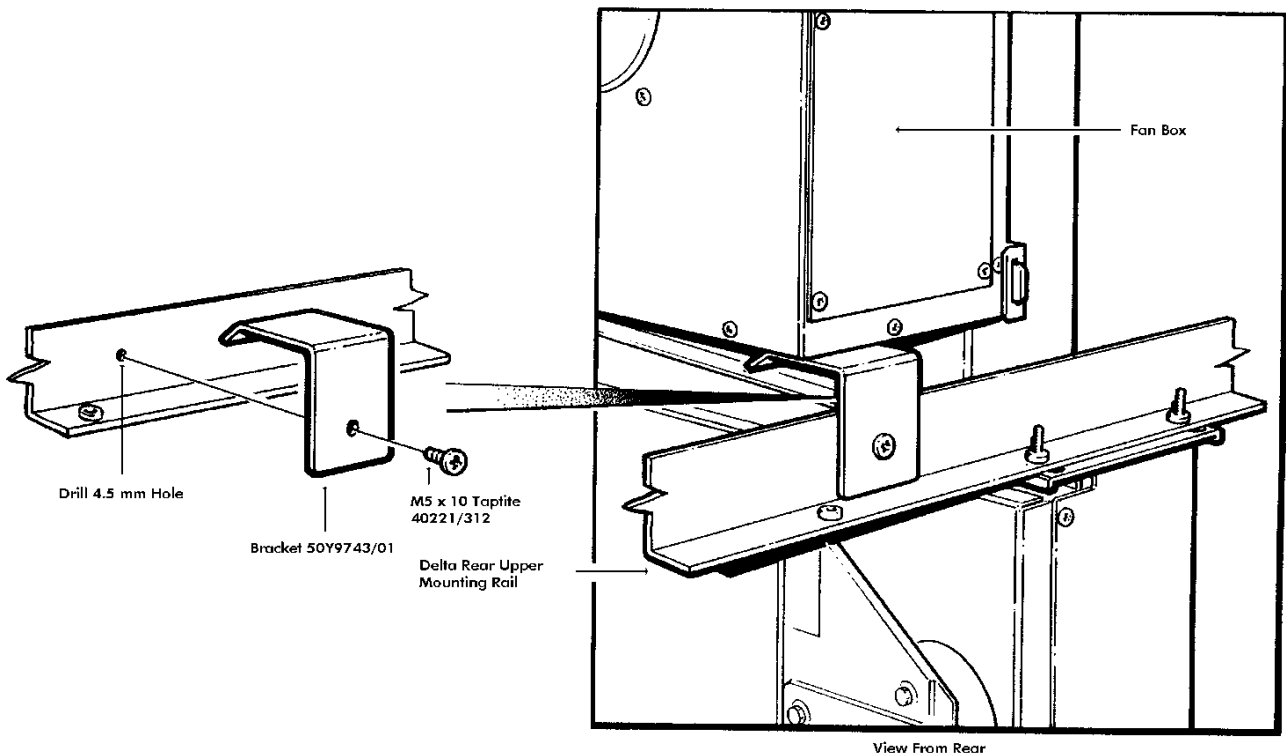

Figure 4 - Fitting of fan support bracket (50Y9743/01)

High Voltages

**Replace all shrouds and close all doors before energizing the equipment.
Connect this equipment to ground (earth) using the ground terminal provided.
The minimum size of the protective conductor must be in accordance with local safety regulations.**

Caution

Ensure all conductors connected to this product are mechanically restrained.

- The single-phase supply input to the fan is through the terminal block (TB1) located on the front of the module - see Figure 1.
- The fan motor is protected from overtemperature by an internal thermal cut-out. This will switch off the internal motor controller and stop the fan. This may lead to the module being cooled by the fan, to trip on overtemperature. Fan re-start is automatic when the fan motor temperature falls below the reset temperature.
- For wiring protection, the fan supply should be fused.

8. Installation & Commissioning

- If it is necessary to perform insulation tests on the converter cubicle, the fan assembly must only be tested at a maximum of 1000 VAC.

8.1 Commissioning

- If the local safety regulations do not permit reliance on direct metal to metal contact to earth this unit, then the earthing connection TB1/9 must be used.
- When the system is being commissioned measure the level of audible noise emitted by the equipment and compare with the legal limits. If the levels are greater than 70dB(A) check all ducting to see if any improvements can be made to reduce the audible noise. If no improvements can be made ensure that the area in which the equipment is located is identified as a restricted area for which appropriate ear protection should be worn.

8.2 Cabling

- Ensure all cables connected to this unit are adequately restrained.

9. Glossary of Terms

AC	Alternating Current
ACD	Air Cooled Delta
DC	Direct Current

10. Contact Details for Sales, Service and Support

- Please refer to your local technical support center if you have any queries about this product.

Avid Controls Inc.
41261 Park 290 Drive, Waller, TX 77484, USA
info@avidcontrolsinc.com
(+1) (281) 640-8600

11. Document Revision History

Rev.	Date	Author	Changes
00	29 th Jan 2018	Mark Woods	Original Issue