



T2034EN Technical Manual Rev 12

MODBUS TCP Ethernet Global Data

Ethernet Interface MVS3012-4001 & MVS3012-4002



DOCUMENT HISTORY

Revision Number	Date Of Revision	Details
Issue 0001	06/2005	Original Issue
Issue 0002	02/2006	Compatibility note paragraph 1.3 added. Cable type revised.
Issue 0003	06/2006	Company name change.
Issue 0004	01/2007	Addition of Ethernet Global Data.
Issue 0005	11/2007	Addition of Ethernet Backup channel mode.
Issue 0006	09/2009	Addition of DHCP.
Issue 0007	11/2009	Addition of note on the use of DHCP.
Issue 0008	07/2011	Menu 35 parameter description added.
Issue 0009	14 May 2012	GE Re-branding, etc.
Rev 0010	April 2013	Company name change, etc.
Rev 0011	April 2013	Note added to Table 5-2 – Ethernet Interface Menu 35 and Section 5.3.23.
Rev 0012	March 2021	Company name change, etc.

DEFINITIONS

- NOTE:** Notes separate important information from the text and give additional information.
- CAUTION** “An instruction that draws attention to the risk of damage to the product, process or surroundings” (BS 4884-1: 1992).
- WARNING** “An instruction that draws attention to the risk of injury or death” (BS 4884-1: 1992).

© COPYRIGHT 2021 All rights reserved. This document and the information it contains is the property of Avid Controls, Inc. under license from General Electric Company and/or its affiliates. It has been provided solely for private use. Copying, reproducing, selling, importing, exporting, displaying, transmitting or distributing this document and any of the information it contains is strictly prohibited except as expressly authorized in writing by Avid Controls, Inc. and/or its affiliates.

SAFETY INSTRUCTIONS

Care has been taken with the design of this product to ensure that it is safe. However, in common with all products of this type, misuse can result in injury or death. Therefore, it is very important that the instructions in this manual and on the product are observed during transportation, commissioning, operation, maintenance and disposal.

This technical manual must be regarded as part of the product. It should be stored with the product and must be passed on to any subsequent owner or user. Local safety laws and regulations must always be observed.

Persons working on the product must be suitably skilled and should have been trained in that work for these products.

The product is a component designed for incorporation in installations, apparatus and machines. The product must not be used as a single item safety system. In applications where maloperation of the product could cause danger, additional means must be used to prevent danger to persons.

Product approvals and certifications will be invalidated if the product is transported, used or stored outside its ratings or if the instructions in this manual are not observed.

Third party approvals to safety standards UL508C and CSA C22.2 No 14 are marked on the product.

In The European Union:

Products within the scope of the Low Voltage Directive, 2006/95/EC are CE marked.

The product complies with the essential protection requirements of the EMC directive 2004/108/EC, when installed and used as described in this manual.

The requirements of the EMC Directive should be established before any installation, apparatus or machine, which incorporates the product, is taken into service. A machine must not be taken into service until the machine has been declared in conformity with the provisions of the Machinery (Safety) Directive, 2006/42/EC.

DISPOSAL

This equipment or any part of the equipment should be disposed of in accordance with the laws of the country of use.

Modern high technology materials have been used in the manufacture of the equipment to ensure optimum performance. Care has been taken with the selection of these materials to minimise risks to health and safety. However, some materials require special consideration during disposal.

In common with all products of this type, the high voltage electrolytic capacitors contain an electrolyte, which must be disposed of as hazardous waste. The electrolytes are solutions of organic and/or boric acid. The major solvents in the capacitors are butyrolactone and ethylene glycol. The electrolyte is non-carcinogenic, but may cause irritation to the skin if contact is prolonged.

Liquid coolant is subject to special considerations during handling, storage and disposal. Refer to the manufacturer's instructions.

SCOPE

This publication should be read in conjunction with the appropriate Standard Product and/or MV3000e Manuals. This publication should be regarded as part of the product; it should be retained for the life of the product and passed on to any subsequent owner or user.

This manual describes the Ethernet facilities supported by the MV3000e Drive and provides detailed descriptions of the related drive parameters, which must be used to configure, monitor and operate the Ethernet Interfaces, MVS3012-4001 & MVS3012-4002.

OVERVIEW

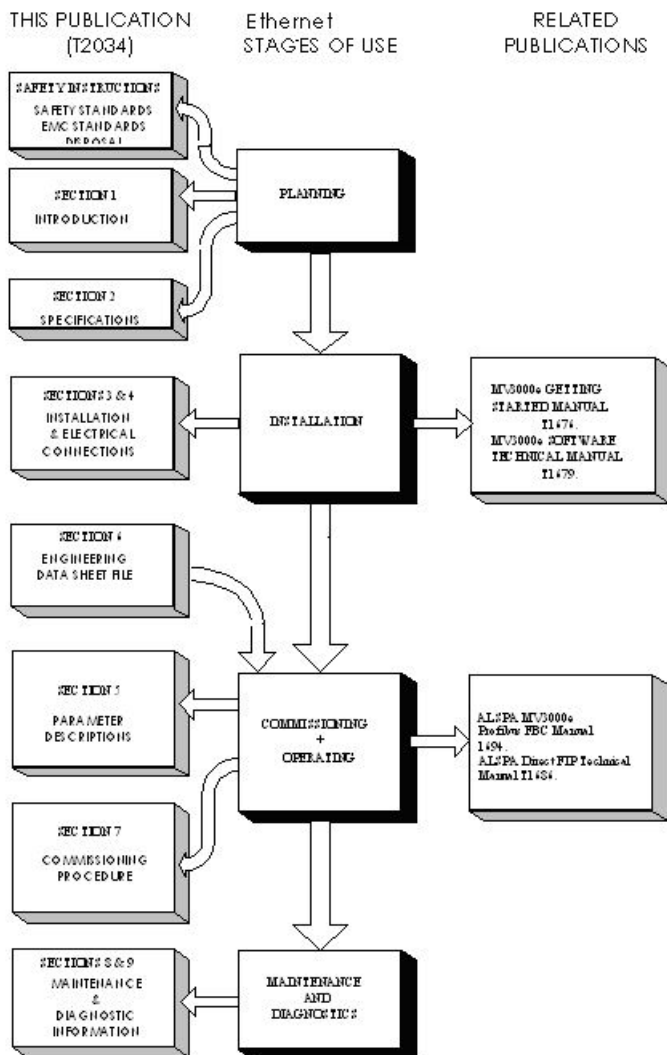

TERMINOLOGY

Acronyms and Definitions

The following definitions, acronyms and terms are used within this manual:

CDC	Common Drive Controller the control boards for the MV3000e range of drives.
CFSRC	A Control Flag Source
CRC	Cyclic Redundancy Check
CW	Control Word
DHCP	Dynamic Host Configuration Protocol
EGD	Ethernet Global Data
FBC	Field Bus Coupler
FS	Full Scale
GND	Ground
H	Used in this manual to indicate a number is hexadecimal
IP	Internet Protocol
MAC-ID	Media Access Controller-Identifier, this is the Ethernet term for a node address
PIB	Power Interface Board, the control board which interfaces the CDC to the output switching devices.
Src	Source
STP	Shielded Twisted Pair
TCP	Transmission Control Protocol
UDP	User Datagram Protocol
VSD	Variable Speed Drive

Protocol Terms & Definitions

Consumer	A device that is a receptor and user of data on a network.
Master Node	A node that controls the communication with a Slave Node.
Node	In a communications network it is a device connected to the network capable of communicating with other network devices. In a more generic sense, it is a connection point on a bus or a network.
Peer-to-peer	Devices at the same level that can talk to each other.
Producer	A device that is a source and transmitter of data on a network.
Producer/consumer Network	A network that is a combination of producers and consumers and in which there is no control of data transfer across the network, all devices having an equal or hierarchical access to the network, other than mechanisms inherently in-built into the network.
Slave Node	A node that responds to instructions from a Master Node.

CONTENTS

DOCUMENT HISTORY	2
DEFINITIONS	2
SAFETY INSTRUCTIONS	3
DISPOSAL	4
SCOPE	4
OVERVIEW	5
TERMINOLOGY	6
1. INTRODUCTION	12
1.1 GENERAL DESCRIPTION	12
1.2 ETHERNET CONFIGURATION	12
1.2.1 Associated Publications	13
1.3 COMPATIBILITY	13
2. SPECIFICATION	14
2.1 ETHERNET INTERFACE SPECIFICATION	14
2.1.1 Supported Protocols	14
2.1.2 Network Speed	14
2.1.3 Data Refresh Rate	14
2.1.4 Connectors & Connections	14
2.2 MODBUS TCP PROTOCOL	15
2.2.1 Overview	15
2.2.2 TCP/IP Port	15
2.2.3 Port Connections	15
2.2.4 IP Sub-net Mask	15
2.2.5 MODBUS TCP Function Codes	15
2.2.6 FBC Fieldbus Compatibility	16
2.3 ETHERNET GLOBAL DATA PROTOCOL	18
2.3.1 Overview	18
2.3.2 UDP Data Port	18
2.3.3 Port Connections	18
2.3.4 IP Sub-Net Mask	18
2.3.5 EGD Exchange Limits	19
2.3.6 FBC Fieldbus Compatibility	19
3. INSTALLATION	20

3.1	GENERAL	20
3.2	PCB HANDLING INFORMATION	20
3.2.1	Receipt Of Equipment On Site	20
3.2.2	Storage	20
3.3	INSTALLATION PROCEDURE FOR MICROCUBICLE™ DRIVES	21
3.4	INSTALLATION PROCEDURE FOR DELTA SYSTEMS	25
4.	NETWORK CONNECTIONS	27
4.1	ETHERNET CABLE.....	27
4.1.1	Connectors & Connections	27
4.2	EXTERNAL WIRING	29
4.3	CABLE SEGREGATION	29
4.4	NETWORK EARTHING.....	29
4.5	EMC STANDARDS	29
4.6	NETWORK SECURITY	29
5.	ETHERNET PARAMETERS	30
5.1	INTRODUCTION	30
5.2	PARAMETER LISTING	30
5.2.1	Attributes	30
5.3	MENU 86 & MENU 35 DESCRIPTION.....	37
5.3.1	Fieldbus Device P86.00	37
5.3.2	Protocol P86.01 (P86.51)	37
5.3.3	IP Address P86.02 to P86.05 (P86.52 to P86.55)	38
5.3.4	Subnet Mask P86.06 to P86.09 (P86.56 to P86.59)	38
5.3.5	MAC-ID P86.10 to P86.12 (P86.60 to P86.62).....	39
5.3.6	Node Address P86.13 (P86.63)	39
5.3.7	Auto Config P86.14 (P86.64).....	40
5.3.8	Configure P86.15 (P86.65)	40
5.3.9	Link Speed & Duplex P86.16 (P86.66).....	41
5.3.10	Loss Action P86.17 (P86.67).....	41
5.3.11	Fallback Action P86.18 (P86.68).....	42
5.3.12	Communications Status P86.19 (P86.69).....	45
5.3.13	Data Errors P86.20 to P86.23 (P86.70 to P86.73).....	46
5.3.14	S/W Version P86.24 (P86.74).....	47
5.3.15	Reference & Control Words P86.25 to P86.28 (P86.75 to P86.78).....	47
5.3.16	Reference & Control Words Fallback P86.29 to P86.32 (P86.79 to P86.82).....	48
5.3.17	Timeout P86.33 (P86.83)	48
5.3.18	Timeout Scope P86.34 (P86.84).....	49
5.3.19	Consume Action P86.35 (P86.85).....	49

5.3.20	Ch1 Gateway Address P86.36 to P86.39 (P86.86 to P86.89)	51
5.3.21	Use DHCP P86.40 (P86.90)	51
5.3.22	IP Address P86.41 (P86.91) to P86.44 (P86.94).....	51
5.3.23	Menu 35	51
5.4	ETHERNET EGD MENU 87	51
5.4.1	Exchange x No. P87.x0.....	54
5.4.2	Exchange x Type P87.x1	54
5.4.3	Exchange x Period P87.x2.....	55
5.4.4	Exchange x IP Address P87.x3 to P87.x6	55
5.4.5	Exchange x Length P87.x7	55
5.4.6	Exchange x Source P87.x8	55
5.5	DATA SPY PARAMETERS P89.00 TO P89.32 (MODBUS TCP ONLY)	56
6.	ENGINEERING DATA SHEET FILE	59
6.1	INTRODUCTION	59
7.	COMMISSIONING	60
7.1	MECHANICAL CHECKS.....	60
7.2	TOOLS & EQUIPMENT.....	60
7.2.1	Ethernet Configuration.....	61
7.3	PROTOCOL SETUP PROCEDURE	64
7.4	ETHERNET RJ45 CONNECTOR INDICATOR LEDS	65
7.5	ETHERNET CHANNEL INDICATOR LEDS.....	66
7.6	VERIFYING DATA CONTENTS	67
8.	MAINTENANCE	68
8.1	GENERAL GUIDANCE	68
8.2	FIRMWARE REVISIONS	68
9.	DIAGNOSTICS	69
9.1	FAULTS.....	69
9.2	ETHERNET WARNING FAULT CODES	69
9.3	ETHERNET TRIP FAULT CODE.....	69
9.4	STATUS FLAGS	70
9.5	PROTOCOL STATUS P86.19 (P86.69)	70
9.6	SPARES & RE-ORDER INFORMATION.....	70
10.	APPENDIX A.....	71
10.1	ETHERNET CONFIGURATION TABLES.....	71
11.	APPENDIX B.....	76

11.1	INDEX	76
12.	APPENDIX C	79
12.1	BLOCK DIAGRAM	79
13.	CONTACT DETAILS FOR SALES, SERVICE & SUPPORT	80

1. INTRODUCTION

This manual describes the Ethernet facilities supported by the MV3000e Drive and provides detailed descriptions of the related drive parameters, which must be used to configure, monitor and operate the Ethernet Interfaces, MVS3012-4001 & MVS3012-4002.

1.1 GENERAL DESCRIPTION

The Ethernet Interface is used to interface to various Fieldbus protocols implemented over an Ethernet network.

The MV3000e Ethernet Interface is available as either a single Ethernet channel or dual Ethernet channel configuration. Each channel is capable of independent operation on the same or separate Ethernet networks. The dual channel configuration additionally allows redundant communication paths to be configured.

The MV3000e Ethernet Interface can be fitted to the range of MV3000e AC drives and allows the drive to be connected to an Ethernet network.

1.2 ETHERNET CONFIGURATION

The board is parameterised and controlled using the same parameter interface as the rest of the drive. The board may also be configured over the drive's serial links, but it is not practical to configure the board over the Ethernet link itself.

Most of the configuration parameters are protocol independent, providing a common configuration interface whatever the Ethernet Fieldbus protocol is in use.

1.2.1 Associated Publications

- T1676 – MV3000e Getting Started Manual
- T1679 – MV3000e Software Technical Manual
- T1689 – MV DELTA (Air Cooled) Technical Manual
- T1693 – MV DELTA (Liquid Cooled) Technical Manual
- T1694 – PROFIBUS Fieldbus Coupler Technical Manual
- T1686 – Direct FIP Technical Manual

1.3 COMPATIBILITY

The MV3000e Ethernet Interface is only compatible with the following controllers and firmware:

- DELTA Controller MVC3001-4003 (20X4341/20C or later)
- MicroCubicle™ Controller 20X4311/10F
- Firmware revision 11.86 or later
- Firmware revision 12.05 or later for EGD

2. SPECIFICATION

2.1 ETHERNET INTERFACE SPECIFICATION

2.1.1 Supported Protocols

- MODBUS TCP
- Ethernet Global Data

2.1.2 Network Speed

Supports automatic network connection at either of the following:

- 10Mbits/s 10 base T network
- 100Mbits/s 100 base TX network

2.1.3 Data Refresh Rate

Acyclic transfers between the Ethernet Interface and the drive's parameters are serviced every 5ms.

Cyclic transfers, using the FBC compatibility mode, are serviced every 10ms.

2.1.4 Connectors & Connections

The Ethernet connection is achieved by connecting to the 8-pin RJ45 connector using a standard Ethernet STP connector. The Ethernet connector socket has integral LEDs to display the network connection status.

The 6-pin RJ11 connector is only used to reprogram the firmware on the Ethernet Interface¹.

Connectors are grouped per channel as shown below.

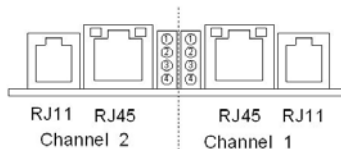

Figure 2-1. – Ethernet Interface Connections

¹ Details of its usage will be provided when a new module firmware version is released for field upgrades

2.2 MODBUS TCP PROTOCOL

2.2.1 Overview

MODBUS is essentially an acyclic transfer protocol. It gains access to the drive's user parameters by issuing a read or write command for a number of parameters starting at address x (x is in the range 0000h to FFFFh, 0 to 65535 decimal). To access the drive's parameters, x is in the range 100 to 9999 decimal to be equivalent to parameters P1.00 through P99.99.

2.2.2 TCP/IP Port

For MODBUS TCP protocol all data packets are sent via a TCP connection with the port number 502.

2.2.3 Port Connections

Two simultaneous MODBUS TCP protocol connections can be supported on port 502. Both of these connections support all the function codes listed in section 2.2.5.

2.2.4 IP Sub-net Mask

The default IP sub-net mask is 255.255.255.0. This means that the client (master) and server have to have IP addresses that have the first 3 fields matching.

2.2.5 MODBUS TCP Function Codes

The following MODBUS function codes are supported

Fn Code	Description	Max. Number of registers
03	Read holding registers	1.. 125 registers
04	Read input registers	1.. 125 registers
06	Write single register	1 register
16	Write multiple registers	1.. 123 registers

Either function code 03 or 04 may be used to read the drive's user parameters.

If an attempt to read/write from/to a non-existent register is made, an exception code is returned. When accessing drive user parameters, all the parameters specified in the register list must exist; otherwise an exception code will be generated.

If an attempt is made to write data that exceeds a drive user parameter's range MODBUS exception code 03 will generated, even though the MODBUS TCP specification excludes this as a usage for this exception code.

2.2.6 FBC Fieldbus Compatibility

The Ethernet interface has been designed to activate the appropriate FBC (Fieldbus Coupler) menus. These menus are for cyclic data transfer only.

Channel present	FBC Menu activated
Ch 1	75
Ch 2	74

This offers access to cyclic data transfer for those protocols that offer this capability.

For the MODBUS TCP protocol, the following addresses are used for the FBC reference and monitor words. These special addresses are:

Addresses 1 to 10 as references, and;

Addresses 11 to 20 as monitor points.

NOTE: The handling of drive parameter read/write via acyclic data transfer is provided by access with MODBUS registers in the address range 40100 to 49999².

In order to use the appropriate FBC Menu, the Ethernet channel must be properly configured using the appropriate Menu 86 parameters. The FBC menu must also be configured in order to activate the FBC features.

The reader is referred to publication T1694 – PROFIBUS Fieldbus Coupler Technical Manual, for details on how to configure and use the FBC menu.

² 30100 to 39999 for read only operation

The following table identifies which FBC pointer parameter is associated with each holding register.

MODBUS Register	Menu 74 Parameter	Description	Menu 75 Parameter	Description
40001	P74.50	FBC1 Rx Word 1 Ptr.	P75.22	CW1 pointer
40002	P74.52	FBC1 Rx Word 2 Ptr.	P75.23	Ref. 1 Pointer
40003	P74.54	FBC1 Rx Word 3 Ptr.	P75.24	Ref. 2 Pointer
40004	P74.56	FBC1 Rx Word 4 Ptr.	P75.25	Ref.3 Pointer
40005	P74.58	FBC1 Rx Word 5 Ptr.	P75.26	Ref. 4 Pointer
40006	P74.60	FBC1 Rx Word 6 Ptr.	P75.27	CW2/Ref. 5 Pointer
40007	P74.62	FBC1 Rx Word 7 Ptr.		
40008	P74.64	FBC1 Rx Word 8 Ptr.		
40009	P74.66	FBC1 Rx Word 9 Ptr.		
40010	P74.68	FBC1 Rx Word 10 Ptr.		
40011	P74.70	FBC1 Tx Word 1 Ptr.	P75.30	Status Word Source
40012	P74.72	FBC1 Tx Word 2 Ptr.	P75.31	FBC1 Tx Word 1 Ptr.
40013	P74.74	FBC1 Tx Word 3 Ptr.	P75.32	FBC1 Tx Word 2 Ptr.
40014	P74.76	FBC1 Tx Word 4 Ptr.	P75.33	FBC1 Tx Word 3 Ptr.
40015	P74.78	FBC1 Tx Word 5 Ptr.	P75.34	FBC1 Tx Word 4 Ptr.
40016	P74.80	FBC1 Tx Word 6 Ptr.	P75.35	FBC1 Tx Word 5 Ptr.
40017	P74.82	FBC1 Tx Word 7 Ptr.		
40018	P74.84	FBC1 Tx Word 8 Ptr.		
40019	P74.86	FBC1 Tx Word 9 Ptr.		
40020	P74.88	FBC1 Tx Word 10 Ptr.		

2.3 ETHERNET GLOBAL DATA PROTOCOL

2.3.1 Overview

Ethernet Global Data (EGD) is essentially a cyclic transfer protocol using previously defined EGD data exchanges. It gains access to the drive's user parameters by performing a read or write to parameters defined by the EGD exchange definition. A produced (from the drive's viewpoint) exchange reads drive parameters and a consumed exchange writes drive parameters.

EGD communicates using the UDP transport layer, which is a connectionless protocol over IP. Data sent via UDP is not acknowledged, so there is no means of detecting or recovering lost packets. However, the cyclic nature of EGD means that the next data exchange is transmitted before user-configured time-outs expire.

The EGD protocol is not intended for one-shot event notification, or for applications with critical data that cannot withstand loss of packet delays.

2.3.2 UDP Data Port

For the EGD protocol all data packets are sent via UDP with the port number 18246 (0x4746, which is equivalent to GF, denoting the GE Fanuc origins).

2.3.3 Port Connections

One bi-directional EGD protocol connection can be supported on port 18246.

2.3.4 IP Sub-Net Mask

The default IP sub-net mask is 255.255.255.0. This means that the client (master) and server have to have IP addresses that have the first 3 fields matching.

2.3.5 EGD Exchange Limits

Each Ethernet channel can support one produced exchange and one consumed exchange. Each EGD exchange can transfer up to 30 words of 16 bits.

If an attempt to read/write from/to a drive parameter in an illegal manner, the relevant drive error parameter is updated but this is not reported via the EGD protocol.

2.3.6 FBC Fieldbus Compatibility

The Ethernet interface has been designed to activate the appropriate FBC (Fieldbus Coupler) menus.

Channel present	FBC Menu activated
Ch 1	75
Ch 2	74

This offers access to cyclic data transfer for those protocols that offer this capability.

These menus have no meaning for the EGD protocol and no attempt should be made to use these menus to transfer data.

3. INSTALLATION

3.1 GENERAL

The Ethernet Interface is one of a range of MV3000e Expansion Bus boards. It is only possible to fit one Expansion Bus board to a standard drive module.

3.2 PCB HANDLING INFORMATION

CAUTION

- **This equipment contains solid state devices which may be affected by electrostatic discharge. Observe static handling precautions.**

NOTE: An anti-static wristband, which is connected to earth, must be worn when handling the Ethernet Interface board.

3.2.1 Receipt Of Equipment On Site

Where the Ethernet Interface board is shipped separate to the general drive assembly, the equipment should be carefully unpacked and inspected for any signs of damage. Check the complete consignment against the packing slip for any loss in transit. If any damage or loss has occurred, contact your local supplier immediately giving the following details:

- A list of damaged or missing items.
- A description of the damage.
- The order number or packing slip details.

3.2.2 Storage

If the equipment delivered to site is not to be installed immediately:

- Re-pack it in its original packing material.
- Store it in a clean dry atmosphere, preferably at room temperature.

3.3 INSTALLATION PROCEDURE FOR MICROCUBICLE™ DRIVES

WARNING

- **This equipment may be connected to more than one live circuit. Disconnect ALL supplies before working on the equipment.**
- **Wait at least 6 minutes after isolating supplies and check that the voltage between DC+ & DC- has reduced to safe level before working on this equipment.**

- a) Switch off the main supply to the drive and ensure that the drive is fully isolated.
- b) Refer to Figure 3-1 and fully open the drive doors as follows:
 - i) Open the left hand yellow plastic door beneath the Keypad harbour by carefully pulling the bottom of the door and/or the depression at the top.
 - ii) Open the right hand door by releasing the two screws I.
- c) Release the screw (A) securing the plastic terminal shroud.
- d) Remove and retain the two screws and washers (B) securing the CDC cassette to the drive chassis.

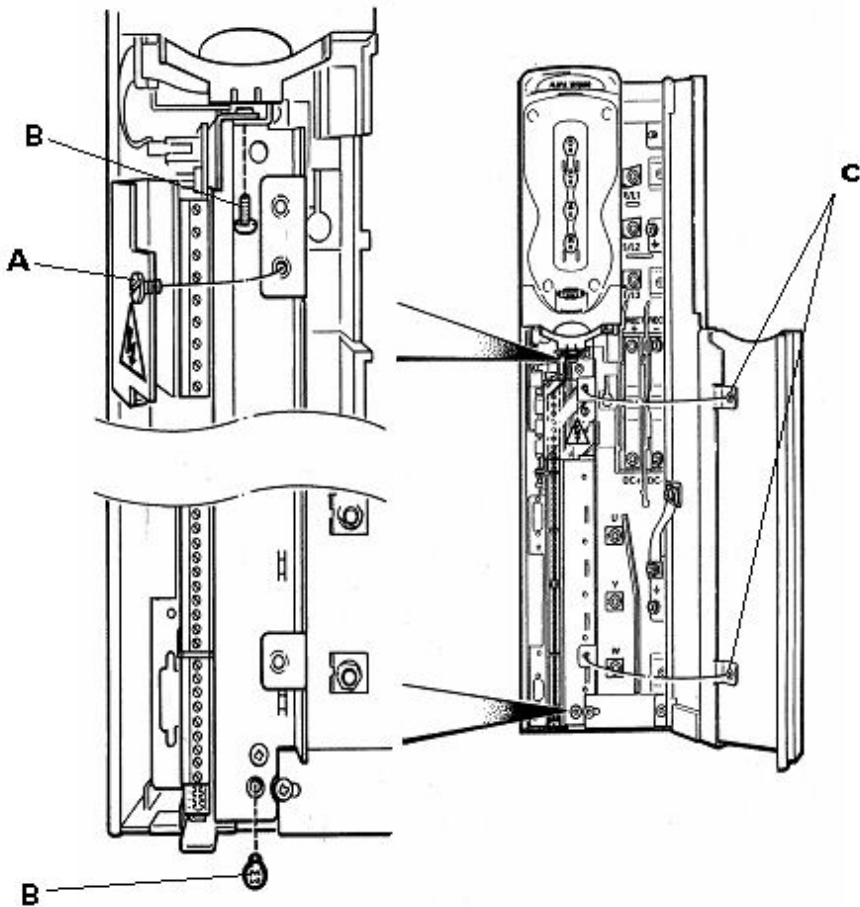

Figure 3-1. – Drive Module: Access & Release the CDC Cassette

- e) Slide the CDC cassette completely forward out of the drive, disconnecting any ribbon connectors located at the top of the board, (see Figure 3-2), and noting their positions for ease of re-connecting.

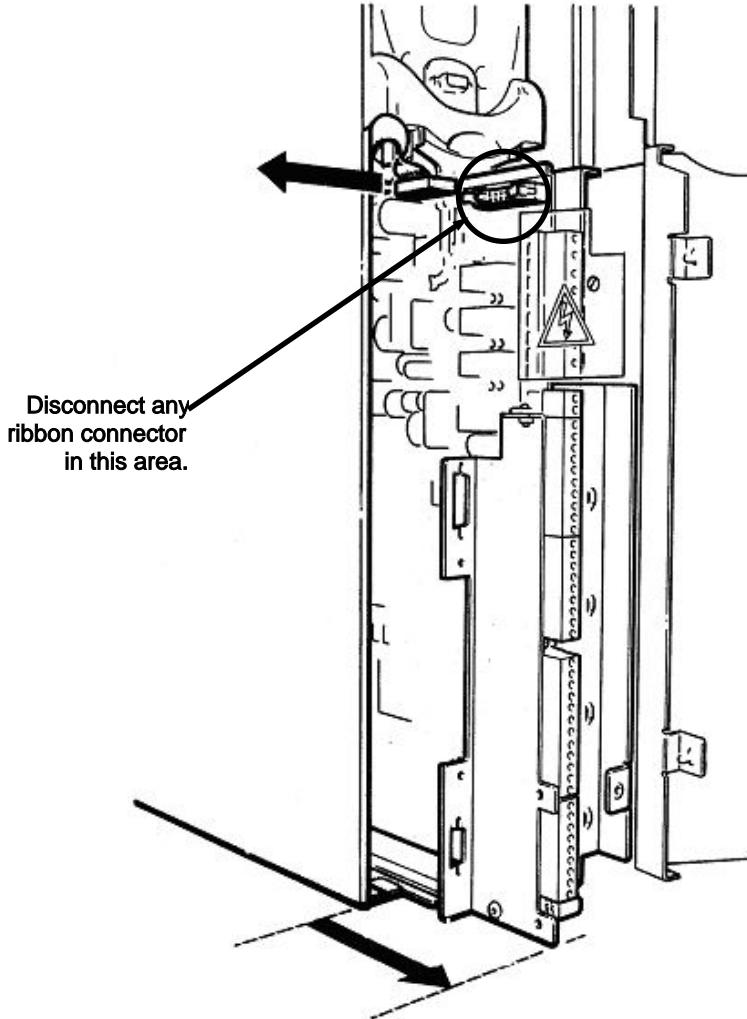

Figure 3-2. – Drive Module: Removing the CDC Cassette

CAUTION

- This equipment contains solid state devices which may be affected by electrostatic discharge. Observe static handling precautions.

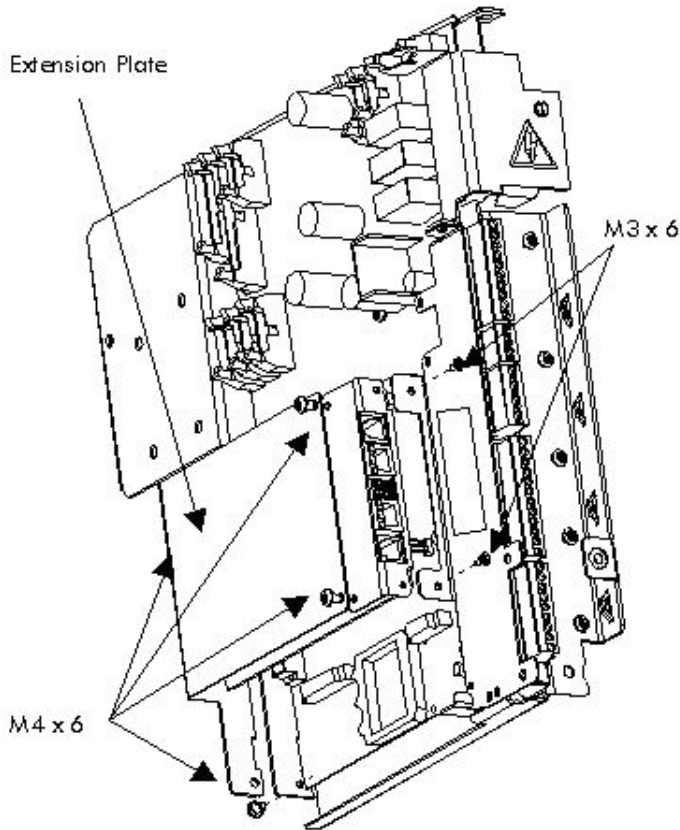

Figure 3-3. – Drive Module: Fitting the Ethernet Interface Module

- f) Fit the Ethernet Interface Module into the 96-way socket at the back of the CDC cassette, as shown in Figure 3-3. Secure it to the steel front plate with the two M3 x 6 screws provided.

- g) Attach the Extension Plate to the rear of the CDC cassette and to the Ethernet Interface Module front plate using the four M4 x 6 screws supplied.
- h) Attach the label to the CDC cassette steelwork.
- i) Slide the CDC cassette back into the drive and re-connect the ribbon connectors that were disconnected at step 4.
- j) Secure the CDC cassette to the drive chassis using the two screws and washers removed at step 3. Close the plastic terminal shroud and secure with the retained screw, then close and secure the drive doors.

3.4 INSTALLATION PROCEDURE FOR DELTA SYSTEMS

- a) Switch off the main supply to the drive and ensure that the drive is fully isolated.

WARNING

- **This equipment may be connected to more than one live circuit. Disconnect ALL supplies before working on the equipment.**
- **Wait at least 6 minutes after isolating supplies and check that the voltage between DC+ & DC- has reduced to safe level before working on this equipment.**

- b) Referring to Figure 3-4 , remove the five M4 screws (E), securing the steel cover plate (G) covering the control board.

NOTE: If this is difficult due to restricted access, remove the MV3000e controller as described in T1689 (Air cooled) or T1693 (Liquid cooled).

CAUTION

- **This equipment contains solid state devices which may be affected by electrostatic discharge. Observe static handling precautions.**

- c) Slide the Ethernet Interface Module over the main control board.

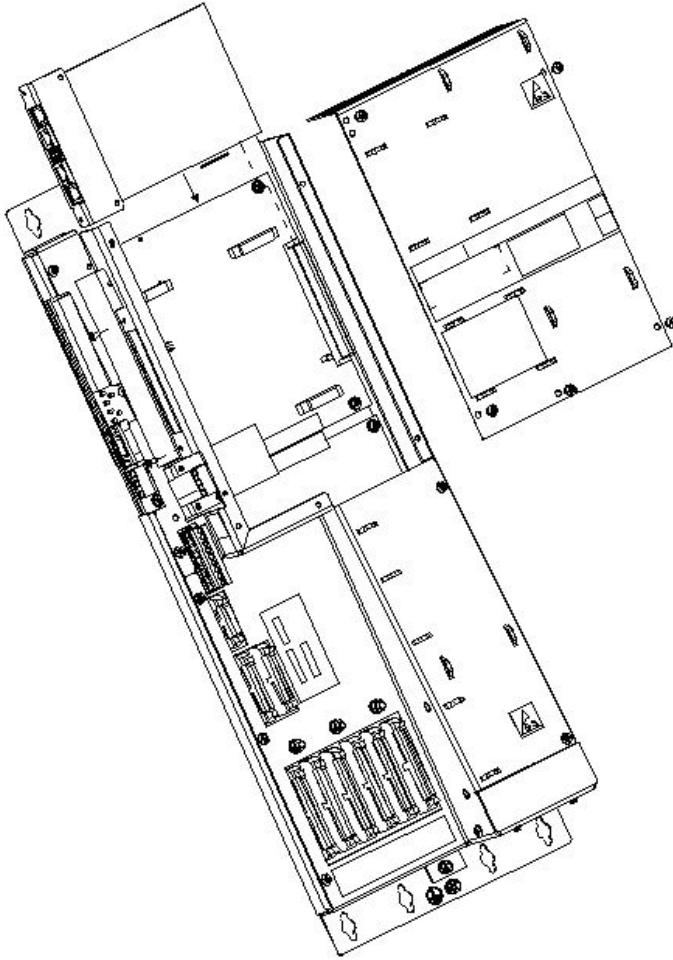

Figure 3-4. – DELTA Systems: Fitting the Ethernet Interface Module

- d) Locate the 96-way connector on the Ethernet Interface Module into the socket (A) at the back of the control board. Secure the front panel of the Ethernet module using two M3 screws (C).
- e) Attach the label (F) if supplied.
- f) Re-fit the cover plate over the control board, using the five screws removed at step 2.

4. NETWORK CONNECTIONS

WARNING

- **This equipment may be connected to more than one live circuit. Disconnect ALL supplies before working on the equipment.**
- **Wait at least 6 minutes after isolating supplies and check that the voltage between DC+ & DC- has reduced to safe level before working on this equipment.**

4.1 ETHERNET CABLE

The connection between an MV3000e AC Drive and other devices using Ethernet is made via a Category 5 (CAT5) Ethernet Shielded Twisted Pair (STP) cable. It is important that the correct cable and connectors are used for the Ethernet network cable. This cable consists of 4 shielded twisted pairs. One pair receives data signals; a second pair transmits data signals³.

4.1.1 Connectors & Connections

The Ethernet connection is achieved by connecting to the 8-pin RJ45 connector using a standard Ethernet STP connector. The Ethernet connector socket can be distinguished as the one that has integral LEDs, which display the network connection status.

The other 6-pin RJ11 connector is used to reprogram the firmware on the Ethernet Interface. Details of how to reprogram the firmware will be provided with the new firmware release.

³ The other 2 pairs are unused

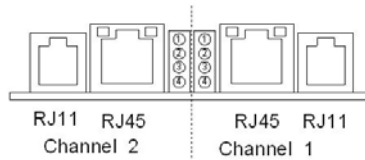

Figure 4-1. – Ethernet Interface Connections

Of the eight pins of the RJ45, only 4 pins are used, these are:

Pin	Use
1	Tx+
2	Tx-
3	Rx+
6	Rx-

The TX (transmitter) pins are connected to corresponding RX (receiver) pins, '+' to '+' and '-' to '-'.

Twisted-pair Ethernet employs two principle means for combating noise. The first is the use of balanced transmitters and receivers within the circuitry of the Ethernet interface. The second is to use twisted pairs for transmit and receive signals. It is very important that a twisted pair is used for Tx and Rx signal pairs.

The Ethernet Interface is wired as a NIC (Network Interface Card). You must use a crossover cable to connect units with identical interfaces. Typically, this is the case for a point-to-point connection between two units without using a network Hub or Switch. Most STP Ethernet networks will make use of Network Hubs/Switches. Network Hubs and Switches invariably require the use of a straight-through cable between the Hub and the unit.

Two wire colour-code standards apply EIA/TIA 568A and EIA/TIA 568B. These two standards use the green and orange pairs for the above transmit and receive signals. The blue and brown pairs are not used in either standard. Cables manufactured to either standard will work, so long as the RJ45 connections at each end of the cable use the same standard.

4.2 EXTERNAL WIRING

It is wise to strain relieve the Ethernet cable before it is connected to the drive. Strain relief helps to prevent damage to the Ethernet connection or the cable becoming unexpectedly unplugged.

Do not run STP cable outside a building without appropriate lightning protection barriers.

4.3 CABLE SEGREGATION

Electrical noise and electromagnetic interference can be introduced into a microelectronics system via the cables and wires connected to it.

Segregation requirements for the wiring and cables connected to a drive, including those for Ethernet, should be implemented to minimise any possibility of interference being introduced into the drive system.

Implementation of segregation requirements involves separating that wiring which could carry electrical noise referred to as 'dirty' wiring, from that which is free from electrical noise, referred to as 'clean' wiring. Wiring that falls into the same group (i.e. 'dirty' or 'clean') can be run together, while wiring from different groups should be kept apart, though paths may cross at right angles. All connections for Ethernet are considered to be clean.

4.4 NETWORK EARTHING

The use of STP Ethernet cable and RJ45 connectors removes the need for additional network cable earthing.

4.5 EMC STANDARDS

In order to meet the required EMC standards the Ethernet Interface Module must be installed as directed in this manual. In addition the Ethernet Interface needs to be connected to an Ethernet switch⁴ that in itself meets the EMC standards when properly installed.

4.6 NETWORK SECURITY

NOTE: It is the responsibility of the user to install this equipment correctly and to ensure the LAN, which it is connected to, is secure.

⁴ The use of Ethernet Hubs is not recommended.

5. ETHERNET PARAMETERS

5.1 INTRODUCTION

This lists the Ethernet user parameters.

5.2 PARAMETER LISTING

5.2.1 Attributes

All parameters have attributes that specify how they may be accessed. The types of attributes used in this manual are:

R	=	Read Only
E	=	Engineer Accessible
O	=	Operator Accessible
L	=	List Parameter
N	=	Enter Parameter
S	=	Stop To Edit

Par No	Name	Default	Range	Attrib.	Comment
P86.00	Fieldbus Device		6=Ethernet I/F 7=Dual Ethernet I/F	R	
P86.01	Ch1 Protocol	0	0 = None 1=MODBUS TCP 2=EGD	E.L.N	Re-configure if changed
P86.02	Ch1 IP Addr 1	0	0 to 255	E	Manually set
P86.03	Ch1 IP Addr 2	0	0 to 255	E	Manually set
P86.04	Ch1 IP Addr 3	0	0 to 255	E	Manually set
P86.05	Ch1 IP Addr 4	0	0 to 255	E	Manually set
P86.06	Ch1 Subnet Mask 1	255	0 to 255	E	Manually set
P86.07	Ch1 Subnet Mask 2	255	0 to 255	E	Manually set
P86.08	Ch1 Subnet Mask 3	255	0 to 255	E	Manually set
P86.09	Ch1 Subnet Mask 4	0	0 to 255	E	Manually set
P86.10	MAC-ID 1&2	0	0000h to FFFFh	R	
P86.11	MAC-ID 3&4	0	0000h to FFFFh	R	
P86.12	MAC-ID 5&6	0	0000h to FFFFh	R	
P86.13	Ch1 Node Address	0	0 to 255	E	
P86.14	Ch1 Auto Config.	0	0=Disable 1=Enable	E.L.N	
P86.15	Configure Ch1	0	0=Disable 1=Enable 2=Reset	E.L.N	
P86.16	Ch1 Link Speed & Duplex	0	0= Auto Negotiate 1= 10Mbits/s HD 2= 10Mbits/s FD 3= 100Mbits/s HD 4= 100Mbits/s FD		HD = Half Duplex FD = Full Duplex
P86.17	Ch1 Loss Action	1	0=Ignore 1=Warn 2=Trip 3= Ignore, trip both 4= Warn, trip both	E.L	Options 3 and 4 are only available if a dual channel interface is fitted.
P86.18	Ch1 Fallback Action	1	0= Freeze 1= Fallback 2= Use other channel	E.L.S	Option 2 is only available if a dual channel

Par No	Name	Default	Range	Attrib.	Comment
					interface is fitted
P86.19	Ch1 Comms. Status	Monitor point	0=On-line 1=Not configured 2=Network not found 3=Not communicating 4=Unknown Protocol 5=Promptness Error 6=Freshness Error 7=Synchronize Error 8=Config. Fault 9=Internal Error 10=Sched. Build Error 11=Scaling Fault 12=Drive Fault	R	Some of these status values will not apply to MODBUS over TCP/IP.
P86.20	Ch1 Tx Error Word	Monitor point	0000h to FFFFh	R.	
P86.21	Ch1 Tx Error Count	Monitor point	0-65535	R	
P86.22	Ch1 Rx Error Word	Monitor point	0000h to FFFFh	R.	
P86.23	Ch1 Rx Error Count	Monitor point	0-65535	R	
P86.24	Ch1 S/W Version	Monitor point	xx.yy where xx = major version, yy = minor version	R	
P86.25	Ch1 Reference 1	0	0.00 to ±100.00		
P86.26	Ch1 Reference 2	0	0.00 to ±100.00		
P86.27	Ch1 Control Word 1	0	0000h to FFFFh	R	Hex / Binary
P86.28	Ch1 Control Word 2	0	0000h to FFFFh	R	Hex / Binary
P86.29	Ch1 Ref 1 Fallback	0	0.00 to ±200.00	E	
P86.30	Ch1 Ref 2 Fallback	0	0.00 to ±200.00	E	
P86.31	Ch1 CW 1 Fallback	0	0000h to FFFFh	E	Hex / Binary

Par No	Name	Default	Range	Attrib.	Comment
P86.32	Ch1 CW 2 Fallback	0	0000h to FFFFh	E	Hex / Binary
P86.33	Ch1 Timeout	10.0	0.0 to 99.9 seconds	E	
P86.34	Ch1 Timeout scope	1	0=disabled 1=All messages 2=Menu 75 Refs only	E.L	
P86.35	Ch1 Consume Action	0	0=Normal	E.L	
P86.36	Ch1 Gateway Addr 1	0	0 to 255	E	Manually set
P86.37	Ch1 Gateway Addr 2	0	0 to 255	E	Manually set
P86.38	Ch1 Gateway Addr 3	0	0 to 255	E	Manually set
P86.39	Ch1 Gateway Addr 4	0	0 to 255	E	Manually set
P86.40	Use DHCP on Ch1	0	0 to 1	E.L	
P86.41	Ch1 IP Address 1	0	0 to 255	R	DHCP set
P86.42	Ch1 IP Address 2	0	0 to 255	R	DHCP set
P86.43	Ch1 IP Address 3	0	0 to 255	R	DHCP set
P86.44	Ch1 IP Address 4	0	0 to 255	R	DHCP set
P86.45	Reserved for future use				
:					
P86.50	Reserved for future use				
P86.51	Ch2 Protocol	0	0 = None 1=MODBUS TCP 2=EGD	E.L.N	
P86.52	Ch2 IP Addr 1	0	0 to 255	E	Manually set
P86.53	Ch2 IP Addr 2	0	0 to 255	E	Manually set
P86.54	Ch2 IP Addr 3	0	0 to 255	E	Manually set
P86.55	Ch2 IP Addr 4	0	0 to 255	E	Manually set
P86.56	Ch2 Subnet Mask Addr 1	255	0 to 255	E	Manually set
P86.57	Ch2 Subnet Mask Addr 2	255	0 to 255	E	Manually set
P86.58	Ch2 Subnet Mask Addr 3	255	0 to 255	E	Manually set
P86.59	Ch2 Subnet Mask Addr 4	0	0 to 255	E	Manually set
P86.60	MAC-ID 1&2	0	0000h to FFFFh	R	
P86.61	MAC-ID 3&4	0	0000h to FFFFh	R	
P86.62	MAC-ID 5&6	0	0000h to FFFFh	R	
P86.63	Ch2 Node Address	0	0 to 255	E	
P86.64	Ch2 Auto Config.	0	0=Disable 1=Enable	E.L.N	
P86.65	Configure Ch2	0	0=Disable 1=Enable	E.L.N	

Par No	Name	Default	Range	Attrib.	Comment
			2=Reset		
P86.66	Ch1 Link Speed & Duplex	0	0= Auto Negotiate 1= 10Mbits/s HD 2= 10Mbits/s FD 3= 100Mbits/s HD 4= 100Mbits/s FD		HD = Half Duplex FD = Full Duplex
P86.67	Ch2 Loss Action	1	0=Ignore 1=Warn 2=Trip 3= Ignore, trip both 4= Warn, trip both	E.L	
P86.68	Ch2 Fallback Action	1	0= Freeze 1= Fallback 2= Use other channel	E.L.S	
P86.69	Ch2 Comms. Status	Monitor point	0=On-line 1=Not configured 2=Network not found 3=Not communicating 4=Unknown Protocol 5=Promptness Error 6=Freshness Error 7=Synchronize Error 8=Config. Fault 9=Internal Error 10=Sched. Build Error 11=Scaling Fault 12=Drive Fault	R	Some of these status values will not apply to MODBUS over TCP/IP.
P86.70	Ch2 Tx Error Word	Monitor point	0000h to FFFFh	R.	
P86.71	Ch2 Tx Error Count	Monitor point	0-65535	R	

Par No	Name	Default	Range	Attrib.	Comment
P86.72	Ch2 Rx Error Word	Monitor point	0000h to FFFFh	R.	
P86.73	Ch2 Rx Error Count	Monitor point	0-65535	R	
P86.74	Ch2 S/W Version	Monitor point	xx.yy where xx = major version, yy = minor version	R	
P86.75	Ch2 Reference 1	0	0.00 to ±100.00		
P86.76	Ch2 Reference 2	0	0.00 to ±100.00		
P86.77	Ch2 Control Word 1	0	0000h to FFFFh	R	Hex / Binary
P86.78	Ch2 Control Word 2	0	0000h to FFFFh	R	Hex / Binary
P86.79	Ch2 Ref 1 Fallback	0	0.00 to ±200.00	E	
P86.80	Ch2 Ref 2 Fallback	0	0.00 to ±200.00	E	
P86.81	Ch2 CW 1 Fallback	0	0000h to FFFFh	E	Hex / Binary
P86.82	Ch2 CW 2 Fallback	0	0000h to FFFFh	E	Hex / Binary
P86.83	Ch2 Timeout	10.0	0.0 to 99.9 seconds	E	
P86.84	Ch2 Timeout scope	1	0=disabled 1=All messages 2= Menu 74 Refs only	E.L	
P86.85	Ch2 Consume Action	0	0=Normal 1=Backup channel	E.L	
P86.86	Ch2 Gateway Addr 1	0	0 to 255	E	Manually set
P86.87	Ch2 Gateway Addr 2	0	0 to 255	E	Manually set
P86.88	Ch2 Gateway Addr 3	0	0 to 255	E	Manually set
P86.89	Ch2 Gateway Addr 4	0	0 to 255	E	Manually set
P86.90	Use DHCP on Ch2	0	0 to 1	E.L	
P86.91	Ch2 IP Address 1	0	0 to 255	R	DHCP set
P86.92	Ch2 IP Address 2	0	0 to 255	R	DHCP set
P86.93	Ch2 IP Address 3	0	0 to 255	R	DHCP set
P86.94	Ch2 IP Address 4	0	0 to 255	R	DHCP set

Table 5-1. – Ethernet Interface Menu 86

NOTE: The parameter list in Table 5-2 – Ethernet Interface Menu 35 is not currently available on the keypad and is reserved for future use/updates.

Par No	Name	Default	Range	Attrib.	Comment
P35.50	Ch1 Gateway Addr 1	0	0 to 255	R	Allocated manually or by DHCP
P35.51	Ch1 Gateway Addr 2	0	0 to 255	R	Allocated manually or by DHCP
P35.52	Ch1 Gateway Addr 3	0	0 to 255	R	Allocated manually or by DHCP
P35.53	Ch1 Gateway Addr 4	0	0 to 255	R	Allocated manually or by DHCP
P35.54	Ch1 Subnet Mask 1	0	0 to 255	R	Allocated manually or by DHCP
P35.55	Ch1 Subnet Mask 2	0	0 to 255	R	Allocated manually or by DHCP
P35.56	Ch1 Subnet Mask 3	0	0 to 255	R	Allocated manually or by DHCP
P35.57	Ch1 Subnet Mask 4	0	0 to 255	R	Allocated manually or by DHCP
P35.58	Ch2 Gateway Addr 1	0	0 to 255	R	Allocated manually or by DHCP
P35.59	Ch2 Gateway Addr 2	0	0 to 255	R	Allocated manually or by DHCP
P35.60	Ch2 Gateway Addr 3	0	0 to 255	R	Allocated manually or by DHCP
P35.61	Ch2 Gateway Addr 4	0	0 to 255	R	Allocated manually or by DHCP
P35.62	Ch2 Subnet Mask 1	0	0 to 255	R	Allocated manually or by DHCP
P35.63	Ch2 Subnet Mask 2	0	0 to 255	R	Allocated manually or by DHCP
P35.64	Ch2 Subnet Mask 3	0	0 to 255	R	Allocated manually or by DHCP
P35.65	Ch2 Subnet Mask 4	0	0 to 255	R	Allocated manually or by DHCP
P35.66	Ch1 IP Address 1	0	0 to 255	R	Allocated manually or by DHCP
P35.67	Ch1 IP Address 2	0	0 to 255	R	Allocated manually or by DHCP
P35.68	Ch1 IP Address 3	0	0 to 255	R	Allocated manually or by DHCP
P35.69	Ch1 IP Address 4	0	0 to 255	R	Allocated manually or by DHCP
P35.70	Ch2 IP Address 1	0	0 to 255	R	Allocated manually or by DHCP
P35.71	Ch2 IP Address 2	0	0 to 255	R	Allocated manually or by DHCP
P35.72	Ch2 IP Address 3	0	0 to 255	R	Allocated manually or by DHCP
P35.73	Ch2 IP Address 4	0	0 to 255	R	Allocated manually or by DHCP

Table 5-2. – Ethernet Interface Menu 35

5.3 MENU 86 & MENU 35 DESCRIPTION

Menu 86 becomes visible when an Ethernet interface expansion bus device is detected as being present. In the following sections, Channel 1 parameters are detailed; the equivalent channel 2 parameter is displayed in parenthesis.

5.3.1 Fieldbus Device P86.00

The Fieldbus device parameter is a read only value that indicates the type of Expansion bus board bus fitted to the system. Valid values for the Ethernet interfaces are:

- Ethernet I/F
- Dual Ethernet I/F

If a dual channel Ethernet interface is detected, parameters for the second channel become visible, otherwise only the parameters for the first channel are visible.

5.3.2 Protocol P86.01 (P86.51)

This displays the list of available protocols for this channel. The available protocols are:

- MODBUS TCP
- EGD

EGD requires that the Ethernet channel software version (see P86.24 (P86.74)) is 2.00 or greater.

Other values are reserved for future application protocols over Ethernet transport protocol standards.

5.3.3 IP Address P86.02 to P86.05 (P86.52 to P86.55)

These four parameters are used to set up the IP address of the Ethernet channel. This is equivalent to the node address for the channel.

The Ethernet Interface channel requires that a specific and network-unique IP address be assigned to each connected channel. When setting up the client connection (e.g. the PLC), knowledge of the IP address will be required.

The subnet mask is 255.255.255.0. This means that the client and server have to be in the same subnet. In this case the first 3 IP address fields must match.

There are recognised standards for the allocation of IP addresses. Consult with the Network Administrator to select a suitable range of IP addresses for use with the Ethernet network configuration.

Example

For IP Address 192.168.1.201 on Channel 1

P86.02 = 192; P86.03 = 168; P86.04 = 1; P86.05 = 201

For IP Address 192.168.1.202 on Channel 2

P86.52 = 192; P86.53 = 168; P86.54 = 1; P86.55 = 202

5.3.4 Subnet Mask P86.06 to P86.09 (P86.56 to P86.59)

These four parameters are used to set up the Subnet Mask for the Ethernet channel.

The default subnet mask is 255.255.255.0. This means that the client and server have to be in the same subnet. In this case the first 3 IP address fields must match. The default values are compatible with Ethernet module firmware versions 2.02 and earlier; and with controller firmware versions 13 and earlier.

5.3.5 MAC-ID P86.10 to P86.12 (P86.60 to P86.62)

Used to display the Ethernet MAC Address allocated to the channel.

The MAC Address is shown as zero until the Ethernet channel is configured using P86.15 (P86.65 for channel 2).

The MAC Address of any Ethernet unit has to be unique for the Ethernet transport protocol to function.

The MAC Address is displayed in hexadecimal format, corresponding to the normal Ethernet MAC-ID format. Each parameter contains two of the MAC Address fields. P86.10 displays the two most significant MAC Address fields.

The MAC Address will be in the range 00:80:6C:00:00:00 through to 00:80:6C:FF:FF:FF. The first 3 MAC Address fields identify the manufacturer and will be common to all Ethernet Interface boards. The last 3 MAC Address fields will differ depending upon order of manufacture. A MAC Address of 00:80:6C:FF:FF:FF denotes the first Ethernet channel to be configured, channels manufactured later have a MAC Address with a lower value. Dual channel versions of the Ethernet Interface are expected to have consecutive MAC Address numbers.

5.3.6 Node Address P86.13 (P86.63)

Normally the unit identifier is set to 0 or 255 and plays no part in the addressing, as the IP address is sufficient. Not all protocols require this parameter; however, there are special cases where the unit identifier is necessary. The following table details whether this parameter needs setting-up.

Protocol	Action	Range
MODBUS TCP	Not required to be set	0-255
EGD	Not required to be set	0-255

Table 5-3. – Node Address

5.3.7 Auto Config P86.14 (P86.64)

WARNING

- **The user should be aware that allowing the Ethernet link to automatically configure and run on power up, could represent a possible safety hazard, as the data from the network will be acted on by the Drive.**

Many users may require the Ethernet link to be automatically configured and run as the drive powers up. This option is available by setting P86.14 to a 1. This would normally be the last step during commissioning of the link.

For safety reasons the value of P86.14 is set to a default value of zero.

5.3.8 Configure P86.15 (P86.65)

Once the protocol, IP address and other parameters have been entered, it is necessary to instruct the firmware to update the Ethernet Interface's channel configuration. Setting P86.15 to 1 does this. The firmware automatically rewrites this value to a zero when configuration is complete. Only after this occurs will any changes to the interface's configuration take effect.

Option 2 (Reset) allows the user to perform a reset of the Ethernet channel. After a reset, the channel is in the not configured state. This also applies to the associated cyclic data FBC menus 74 and 75. The protocol and IP address can only be configured once after each reset event.

NOTE: **A reset event occurs at power up. Thus, if the IP address needs changing, the new IP address must be programmed and then the channel must be reset (option 2) and configured (option 1). Option 2 is also useful when performing an Ethernet channel firmware update via the serial port. Details of this procedure will be provided if a firmware update is necessary.**

5.3.9 Link Speed & Duplex P86.16 (P86.66)

This parameter is used to configure the Ethernet link speed and duplex/half duplex operation. Normally the channel is set to auto-negotiate this requirement. The remaining options are to set the link to fixed 10Mbits/s or 100Mbits/s operation at either full or half duplex. When using one of the fixed settings, the equipment at the other end of the link must be configured identically.

NOTE: Any change to this parameter's value will require a channel re-configure i.e. P86.15 (86.65) set = 2 and then set = 1. Until that time, the channel will be in auto-negotiate mode.

5.3.10 Loss Action P86.17 (P86.67)

A loss of reference may be declared if the Ethernet link detects a loss of communications with the master (client). When a loss of reference is declared, one of a number of things can happen, depending upon the setting.

Valid Values:

0. ignore loss of reference errors and carry on running.
1. upon a loss of reference set a warning and continue running.
2. upon a loss of reference trip the drive.
3. ignore loss of reference errors and carry on running until the other channel also fails then trip the drive.
4. upon a loss of reference set a warning and carry on running until the other channel also fails then trip the drive.⁵

Generating a warning alerts the user to the fault while allowing the drive to continue running. Generating a trip causes the drive to stop. Two further options allow the drive to be configured to trip when both channels become unhealthy, optionally warning when the channel fails. Used in conjunction with the Fallback Action parameter, a redundant-path data communications system can be configured.

The warning code for loss of communications is 143 (144 for channel 2), and the trip code is 220 (221 for channel 2.)

Status flag 87 (88 for channel 2) indicates whether Field Bus communications are healthy or not. Status flags 87 and 88 can be viewed using parameter P11.42.

⁵ Options 3 and 4 are intended for use when configuring a redundant path network and are only available if a dual channel interface is fitted.

5.3.11 Fallback Action P86.18 (P86.68)

In the event of a failure of the channel 1 communications, the drive can be configured to do one of the following:

Option	Meaning	Comment
0	Freeze	The current values in the reference and control word parameters remain unchanged.
1	Fallback	The current values in the reference and control word parameters are replaced by the relevant reference and control word fallback values.
2	Use Other Channel	The current values in the reference and control word parameters are replaced by the relevant reference and control word values from the other channel.

Table 5-4. – Fallback Action

Option 0 allows the drive to continue running with the last good set of data from the Ethernet network.

Option 1 allows the user to define a default mode of operation.

Option 2 allows the other channel to be used as a backup channel.

With option 2, a redundant-path communications configuration is possible. Various reference pointers (Pointers 8, 21 and 22 can be used for the selection of Ethernet as Torque or Speed Reference sources) are used to select the primary channel (i.e. channel 1 or channel 2). The other channel then becomes the secondary (backup) channel. If the primary channel is healthy, the other channel's data is not used. If the primary channel goes unhealthy, then the other channel's data is used. In the event of both channels being unhealthy, the secondary channel could even be configured to use its fallback values.

Channel 1, P86.18 set = 2 – ‘Use Other Channel Data’			
Channel 2, P86.68 set = 2 – ‘Use Other Channel Data’			
Data Used	Ch1 State	Ch2 State	Data Used
Channel 1 uses Channel 1 Incoming Data	HEALTHY	HEALTHY	Channel 1 uses Channel 1 Incoming Data
Channel 1 uses Channel 2 Data	FAULT	HEALTHY	Channel 2 uses Channel 2 Incoming Data
Channel 1 uses Channel 1 Fallback Values	FAULT	FAULT	Channel 2 uses Channel 2 Fallback Values
Channel 1 uses Channel 1 Incoming Data	HEALTHY	HEALTHY	Channel 2 uses Channel 2 Incoming Data
Channel 1 uses Channel 1 Incoming Data	HEALTHY	FAULT	Channel 2 uses Channel 1 Data
Channel 1 uses Channel 1 Fallback Values	FAULT	FAULT	Channel 2 uses Channel 2 Fallback Values

Table 5-5. – Operating Setup 1

Channel 1, P86.18 set = 2 – ‘Use Other Channel Data’			
Channel 2, P86.68 set = 1 – ‘Fallback’			
Data Used	Ch1 State	Ch2 State	Data Used
Channel 1 uses Channel 1 Incoming Data	HEALTHY	HEALTHY	Channel 2 uses Channel 2 Incoming Data
Channel 1 uses Channel 2 Data	FAULT	HEALTHY	Channel 2 uses Channel 2 Incoming Data
Channel 1 uses Channel 1 Fallback Values	FAULT	FAULT	Channel 2 uses Channel 2 Fallback Values
Channel 1 uses Channel 1 Incoming Data	HEALTHY	HEALTHY	Channel 2 uses Channel 2 Incoming Data
Channel 1 uses Channel 1 Incoming Data	HEALTHY	FAULT	Channel 2 uses Channel 2 Fallback Values
Channel 1 uses Channel 1 Fallback Values	FAULT	FAULT	Channel 2 uses Channel 2 Fallback Values

Table 5-6. – Operating Setup 2a

Channel 1, P86.18 set = 1 – ‘Fallback’			
Channel 2, P86.68 set = 2 – ‘Use Other Channel Data’			
Data Used	Ch1 State	Ch2 State	Data Used
Channel 1 uses Channel 1 Incoming Data	HEALTHY	HEALTHY	Channel 2 uses Channel 2 Incoming Data
Channel 1 uses Channel 1 Fallback Values	FAULT	HEALTHY	Channel 2 uses Channel 2 Incoming Data
Channel 1 uses Channel 1 Fallback Values	FAULT	FAULT	Channel 2 uses Channel 2 Fallback Values
Channel 1 uses Channel 1 Incoming Data	HEALTHY	HEALTHY	Channel 2 uses Channel 2 Incoming Data
Channel 1 uses Channel 1 Incoming Data	HEALTHY	FAULT	Channel 2 uses Channel 1 Incoming Data
Channel 1 uses Channel 1 Fallback Values	FAULT	FAULT	Channel 2 uses Channel 2 Fallback Values

Table 5-7. – Operating Setup 2b

Channel 1, P86.18 set = 2 – ‘Use Other Channel Data’			
Channel 2, P86.68 set = 0 – ‘Freeze’			
Data Used	Ch1 State	Ch2 State	Data Used
Channel 1 uses Channel 1 Incoming Data	HEALTHY	HEALTHY	Channel 2 uses Channel 2 Incoming Data
Channel 1 uses Channel 2 Incoming Data	FAULT	HEALTHY	Channel 2 uses Channel 2 Incoming Data
Channel 1 uses Channel 1 Fallback Values	FAULT	FAULT	Channel 2 Freezes On Last Received Valid Data
Channel 1 uses Channel 1 Incoming Data	HEALTHY	HEALTHY	Channel 2 uses Channel 2 Incoming Data
Channel 1 uses Channel 1 Incoming Data	HEALTHY	FAULT	Channel 2 Freezes On Last Received Valid Data
Channel 1 uses Channel 1 Fallback Values	FAULT	FAULT	Channel 2 Freezes On Last Received Valid Data

Table 5-8. – Operating Setup 3a

Channel 1, P86.18 set = 0 – ‘Freeze’			
Channel 2, P86.68 set = 2 – ‘Use Other Channel Data’			
Data Used	Ch1 State	Ch2 State	Data Used
Channel 1 uses Channel 1 Incoming Data	HEALTHY	HEALTHY	Channel 2 uses Channel 2 Incoming Data
Channel 1 Freezes On Last Received Valid Data	FAULT	HEALTHY	Channel 2 uses Channel 2 Incoming Data
Channel 1 Freezes On Last Received Valid Data	FAULT	FAULT	Channel 2 Uses Channel 2 Fallback Values
Channel 1 uses Channel 1 Incoming Data	HEALTHY	HEALTHY	Channel 2 uses Channel 2 Incoming Data
Channel 1 uses Channel 1 Incoming Data	HEALTHY	FAULT	Channel 2 Uses Channel 1 Incoming Data
Channel 1 uses Channel 1 Fallback Values	FAULT	FAULT	Channel 2 Uses Channel 2 Fallback Values

Table 5-9. – Operating Setup 3b

5.3.12 Communications Status P86.19 (P86.69)

This parameter displays one of the values shown in Table 5-10, depending upon the state of the Ethernet channel.

Value	State	Meaning
0	On-line	The Ethernet channel is communicating correctly.
1	Not configured.	The Ethernet channel has not yet been configured with a valid node address.
2	Network not found	The Ethernet channel has been configured, but no network messages have been detected.
3	Not communicating	The Ethernet channel has been configured, the network baud rate deduced from the presence of traffic, but either this slave address is not being polled from the master, or the Ethernet channel does not support the type of data packet the master is configured for.

Table 5-10. – Communication Statuses

5.3.13 Data Errors P86.20 to P86.23 (P86.70 to P86.73)

When transferring data between the Ethernet link and the Drive parameters, several possible errors could occur. If an error does occur then it is logged in P86.20 or P86.22. Parameters P86.20 and P86.22 log the errors that occurred transferring the data and P86.21 and P86.23 log the total number of errors. The error format is as follows:

- Bit 0 Attempt to write to non-existent parameter.
- Bit 1 Parameter 'write' access denied, parameter has 'R' attribute set.
- Bit 2 Data clamped to lower limit before being written.
- Bit 3 Data clamped to upper limit before being written.
- Bit 4 Data below bit parameter range and not written.
- Bit 5 Data above bit parameter range and not written.
- Bit 6 Attempt to write to read-only parameter.
- Bit 7 Attempt to write to a stop to edit parameter when running, data ignored.
- Bit 8 Attempt to read from a non-existent parameter.
- Bit 9 Parameter read access denied.
- Bit 10 to Bit 15 Reserved.

For each transfer all the data errors are flagged, and a counter is incremented for each transfer error. The error counter is allowed to rollover and is reset when the Ethernet channel is configured.

When writing data outside the normal range of a parameter, the data is clamped to the maximum or minimum value. Bit parameter values outside the normal range are ignored.

For example if the following information was viewed:

P86.20 = 0300h (0000 0011 0000 0000 binary)

P86.21 = 21

This indicates that one of the monitor parameters configured attempted to read from a non-existent parameter, and another parameter attempted to read a parameter that did not have Field Bus read access. The error counter indicates that 21 errors had occurred since the last Ethernet configuration.

5.3.14 S/W Version P86.24 (P86.74)

Displays the Ethernet channel software version in 'Major.Minor' format. This parameter is to allow determination of the version of software within the Ethernet interface itself. There is no requirement for both channels to be at the same software version.

5.3.15 Reference & Control Words P86.25 to P86.28 (P86.75 to P86.78)

These are arranged to be contiguous parameters to allow efficient access by the MODBUS protocol when using the write-multiple function code.

5.3.15.1 Ch 1 Control Word 1 P86.27

Control flags in the Ch1 control word 1 are selected by specifying a control flag source (CFSRC) value in the range 5.300 to 5.315 that corresponds to control word 1 bits 0 to 15 respectively.

5.3.15.2 Ch 1 Control Word 2 P86.28

Control flags in the Ch1 control word 2 are selected by specifying a control flag source (CFSRC) value in the range 5.316 to 5.331 that corresponds to control word 2 bits 0 to 15 respectively.

5.3.15.3 Ch 2 Control Word 1 P86.77

Control flags in the Ch2 control word 1 are selected by specifying a control flag source (CFSRC) value in the range 5.332 to 5.347 that corresponds to control word 1 bits 0 to 15 respectively.

5.3.15.4 Ch 2 Control Word 2 P86.78

Control flags in the Ch2 control word 2 are selected by specifying a control flag source (CFSRC) value in the range 5.348 to 5.363 that corresponds to control word 2 bits 0 to 15 respectively.

5.3.16 Reference & Control Words Fallback P86.29 to P86.32 (P86.79 to P86.82)

These values are programmed by the user to specify the fallback value of the corresponding reference in the event of an unhealthy communications state. The fallback values are only copied to the reference values if the fallback option is selected.

The default value of these parameters is zero. This results in a default fallback-to-zero configuration.

5.3.17 Timeout P86.33 (P86.83)

The channel will go unhealthy when no protocol message has been received for a time greater than this period. A value of zero disables the time-out. Selecting a value of zero is equivalent to ignoring the unhealthy state together with 'freeze' on unhealthy. In this case, the healthy status flag will always remain healthy.

A time-out event will not disable the Ethernet channel as a control or reference source, but it will cause the freeze/fallback event to be executed. It will optionally generate a warning or trip as programmed by the user. It will clear the channel healthy flag to zero.

An understanding of the nature of the protocol selected will allow the value of this parameter to be optimised. In the case of MODBUS TCP, there is no absolute requirement to continuously transmit messages. However, it is likely that the MODBUS master unit will be transmitting messages periodically.

This value has to be non-zero to activate the loss of communications logic.

5.3.18 Timeout Scope P86.34 (P86.84)

The timeout can be reset on receipt of any valid Ethernet message or just on receipt of a valid reference write message.

Option	Meaning	Comment
0	Disable	'Loss of Communication' logic inactive.
1	All messages	The link is healthy provided it has received any valid messages within the time set in P86.33 (P86.83).
2	Reference only	The link is healthy provided it has received a valid reference write message within the time set in P86.33 (P86.83).

Table 5-11. – Time Scope Options

A reference write message is defined as a write to at least one of the FBC cyclic registers. The following table identifies the relevant registers depending upon the protocol selection.

Protocol	Reference Register
MODBUS TCP	Holding register 1 to 10
EGD	Not Applicable

Table 5-12. – Reference Register Addresses

For more details see section 2.2.6 FBC Fieldbus Compatibility.

5.3.19 Consume Action P86.35 (P86.85)

The Consume Action only applies to channel 2, P86.85. P86.35 is limited to a setting of P86.35 = 0 only.

Channel 2 can be set to act as a backup to channel 1. In this mode, the backup channel will only consume data transmitted via Ethernet if the other channel is unhealthy (or not present or not configured). The channel will produce data when asked and will appear to consume the data from the Ethernet perspective.

Option	Meaning	Comment
0	Normal	Channel consumes data no matter what the state of the other channel.
1	Backup Channel	Channel consumes data only when the other channel is unhealthy, not present/not configured.

Table 5-13. – Consume Action Options

In MODBUS TCP mode, the destination registers (i.e. drive parameters) of the consume data is specified in the Modbus message. There is no further 'consume packet' configuration to do in the drive.

In EGD mode, the destination registers are defined in the Exchange packet (see menu 87), and the consume data packet only contains the data for that exchange number. When an Ethernet channel is configured as a backup channel, the exchange data definitions (at the time of configuration) that are allocated to the other channel are used. Any exchanges allocated to this Ethernet channel are not used when the channel is set as the backup channel.

Table 5-14 defines the action while the backup channel is inactive i.e. when the main consume channel is healthy.

Protocol	Consume action when Backup channel is inactive
MODBUS TCP	Incoming data (preset single/multiple registers) is not written to the registers. Modbus master is sent a success code. Chx Rx Error Word is set to 0x0001 to indicate data is not written but the Chx Rx Error Count does not increment. Where x is the backup channel number.
EGD	Incoming data (contained in the other channel's consumed exchange packets) is not written to the registers. Chx Rx Error Word is set to 0x0001 to indicate data is not written but the Chx Rx Error Count does not increment.

Table 5-14. – Consume action When The Backup Channel Is Inactive

WARNING

- **If the Ethernet reference parameters (P86.25 to P86.28 and P86.75 to P86.78) are used as consume data destinations and backup channel consume action is selected, be aware that Chx Fallback Action parameter settings other than Freeze will still be active and will continually overwrite the reference parameters while the other channel is unhealthy. It is therefore strongly recommended that the Chx Fallback Action parameters be set to freeze when Backup Channel mode is selected.**

5.3.20 Ch1 Gateway Address P86.36 to P86.39 (P86.86 to P86.89)

These four parameters are used to set up the Default Gateway Address for the Ethernet channel. The default Gateway Address is 0.0.0.0. The all zeros means the Default Gateway is not configured within the Ethernet card and thus is compatible with Ethernet module firmware versions 2.02 and earlier; and with controller firmware versions 13 and earlier.

5.3.21 Use DHCP P86.40 (P86.90)

P86.40 (P86.90) is the DHCP Enable parameter, enabling this causes the DHCP request function to be activated when the channel is configured - P86.15 (P86.65). When DHCP is enabled the manually assigned IP Address specified in P86.02 (P86.52) to P86.05 (P86.55) will be ignored. The channel IP address, the subnet mask and the gateway address will all be obtained from the external DHCP server and displayed in P35.50 to P35.73.

5.3.22 IP Address P86.41 (P86.91) to P86.44 (P86.94)

These parameters are used to display the allocated IP address and can be used to indicate that DHCP allocation has succeeded, but will also show the static IP address if DHCP is not enabled.

5.3.23 Menu 35

Parameters P35.50 to P35.73 are used to display all the allocated address. These values will be a copy of either the manually assigned addresses or the DHCP assigned addresses, see Table 5-2.

NOTE: The parameter list in Table 5-2 – Ethernet Interface Menu 35 is not currently available on the keypad and is reserved for future use/updates.

5.4 ETHERNET EGD MENU 87

Menu 87 is only for use when the EGD protocol is selected for one or more of the two Ethernet channels.

Table 5-15 Ethernet EGD Menu 87

Par No	Name	Default	Range	Attrib.	Comment
P87.00	Exchange 0 No.		0 to 16383	E	
P87.01	Exch. 0 Type	0	0 Produced by Ch 1 1 Consumed by Ch 1 2 Produced by Ch 2 3 Consumed by Ch 2	E.L.N	
P87.02	Exch. 0 Period	0	0 to 60000 ms	E	
P87.03	Exch. 0 IP Address 1	0	0 to 255	E	
P87.04	Exch. 0 IP Address 2	0	0 to 255	E	
P87.05	Exch. 0 IP Address 3	0	0 to 255	E	
P87.06	Exch. 0 IP Address 4	0	0 to 255	E	
P87.07	Exch. 0 Length	0	0 to 32	E	
P87.08	Exch. 0 Source	0	0 VCOM0 (p) 1 VCOM1 (c) 2 VCOM2 (p) 3 VCOM3 (c) 4 VCOM4 (p) 5 VCOM5 (c) 6 VCOM6 (p) 7 VCOM7 (c)	E.L.N	See menus 83, 84 and 85.
P87.09	Reserved for future use.				Not displayed
P87.10	Exchange 1 No.		0 to 16383	E	
P87.11	Exch. 1 Type	0	0 Produced by Ch 1 1 Consumed by Ch 1 2 Produced by Ch 2 3 Consumed by Ch 2	E.L.N	
P87.12	Exch. 1 Period	0	0 to 60000 ms	E	
P87.13	Exch. 1 IP Address 1	0	0 to 255	E	
P87.14	Exch. 1 IP Address 2	0	0 to 255	E	
P87.15	Exch. 1 IP Address 3	0	0 to 255	E	
P87.16	Exch. 1 IP Address 4	0	0 to 255	E	
P87.17	Exch. 1 Length	0	0 to 32	E	

Table 5-15 Ethernet EGD Menu 87

Par No	Name	Default	Range	Attrib.	Comment
P87.18	Exch. 1 Source	0	0 VCOM0 (p) 1 VCOM1 (c) 2 VCOM2 (p) 3 VCOM3 (c) 4 VCOM4 (p) 5 VCOM5 (c) 6 VCOM6 (p) 7 VCOM7 (c)	E.L.N	See menus 83, 84 and 85.
P87.19	Reserved for future use.				Not displayed
P87.20	Exchange 2 No.		0 to 16383	E	
P87.21	Exch. 2 Type	0	0 Produced by Ch 1 1 Consumed by Ch 1 2 Produced by Ch 2 3 Consumed by Ch 2	E.L.N	
P87.22	Exch. 2 Period	0	0 to 60000 ms	E	
P87.23	Exch. 2 IP Address 1	0	0 to 255	E	
P87.24	Exch. 2 IP Address 2	0	0 to 255	E	
P87.25	Exch. 2 IP Address 3	0	0 to 255	E	
P87.26	Exch. 2 IP Address 4	0	0 to 255	E	
P87.27	Exch. 2 Length	0	0 to 32	E	
P87.28	Exch. 2 Source	0	0 VCOM0 (p) 1 VCOM1 (c) 2 VCOM2 (p) 3 VCOM3 (c) 4 VCOM4 (p) 5 VCOM5 (c) 6 VCOM6 (p) 7 VCOM7 (c)	E.L.N	See menus 83, 84 and 85.
P87.29	Reserved for future use.				Not displayed
P87.30	Exchange 3 No.		0 to 16383	E	
P87.31	Exch. 3 Type	0	0 Produced by Ch 1 1 Consumed by Ch 1 2 Produced by Ch 2 3 Consumed by Ch 2	E.L.N	

Table 5-15 Ethernet EGD Menu 87

Par No	Name	Default	Range	Attrib.	Comment
P87.32	Exch. 3 Period	0	0 to 60000 ms	E	
P87.33	Exch. 3 IP Address 1	0	0 to 255	E	
P87.34	Exch. 3 IP Address 2	0	0 to 255	E	
P87.35	Exch. 3 IP Address 3	0	0 to 255	E	
P87.36	Exch. 3 IP Address 4	0	0 to 255	E	
P87.37	Exch. 3 Length	0	0 to 32	E	
P87.38	Exch. 3 Source	0	0 VCOM0 (p) 1 VCOM1 (c) 2 VCOM2 (p) 3 VCOM3 (c) 4 VCOM4 (p) 5 VCOM5 (c) 6 VCOM6 (p) 7 VCOM7 (c)	E.L.N	See menus 83, 84 and 85.
P87.39	Reserved for future use.				Not displayed

Up to 4 EGD exchanges may be defined for the drive. This allows for one produced and consumed exchange per Ethernet channel. If only one channel is in use, all 4 exchanges can be allocated to the one EGD channel.

Each exchange is defined by 9 parameters, conveniently arranged to start on a parameter decade boundary.

In the following definitions x can have a value between 0 and 3.

5.4.1 Exchange x No. P87.x0

This defines the EGD exchange number to be associated with this exchange definition. EGD allows exchange number up to 16383. A value of 0 disables the exchange.

5.4.2 Exchange x Type P87.x1

This defines which Ethernet channel the exchange is allocated to, and whether it is a producer or consumer. The definition of producer/consumer is from the drive's viewpoint.

5.4.3 Exchange x Period P87.x2

This defines the production period for produced exchanges. For consumed exchanges, the value is not used. The channel timeout parameter (P86.33 or P86.83) should be used instead. The channel timeout period should be set to be greater than two times the production period for that exchange.

5.4.4 Exchange x IP Address P87.x3 to P87.x6

This defines the IP address to send a produced exchange to or to receive a consumed exchange from. Only Unicast point-to-point addressing is supported. Multicast addressing is not supported.

5.4.5 Exchange x Length P87.x7

This defines the length of the exchange, in words, range 0 to 32. EGD reserves the first 2 words of the exchange for status information. So to produce/consume one drive parameter requires an exchange length of 3 and for 30 parameters it requires an exchange length of 32. The number of exchange data bytes is twice this number. This fact is important when configuring other equipment, e.g. a PLC, as they may be working in units of bytes.

5.4.6 Exchange x Source P87.x8

This defines which VCOM list of parameters is to be used to define the parameters referenced by the exchange data. These VCOMs are held in menus 83, 84 and 85 and were originally used for a similar purpose with the FIP protocol. A full description of these VCOM menus is provided in the associated FIP manual. There is no requirement to use the (p) VCOM for produced exchanges and (c) VCOM for consumed exchanges, but it is recommended that they are so as to act as a memory aid.

NOTE: The first 2 words of the VCOM will not be transmitted/received as EGD uses them for status information. It is suggested that parameters such as unused CANopen references/control words are used for this function.

5.5 DATA SPY PARAMETERS P89.00 TO P89.32 (MODBUS TCP ONLY)

The Data Spy parameters are used to help debug and commission the Ethernet network as well as monitoring data transactions during normal operation. Using the spy area of Menu 89 it is possible to monitor the data packet in its unmodified form. **An understanding of the protocol being used is essential.** The data is available in parameters P89.01 to P89.32 and corresponds to the first thirty-two 16-bit words of data being monitored.

If P89.00 contains a parameter number anywhere in the range 86.22 to 86.23, the contents of the received message will be displayed. Similarly the transmitted message will be displayed by setting P89.00 to a value in the range 86.20 to 86.21.

Channel 2 data is accessed using parameter numbers 86.70 to 86.73.

The values are displayed in hexadecimal with no scaling and should be exactly what is being transferred over the Ethernet network. This is to overcome the potential difficulty in being able to decode the received or transmitted data bytes.

The meanings of the display parameters are:

- P89.01, Protocol type (0100h = MODBUS);
- P89.02 to P89.05, MODBUS message header;
- P89.06 to P89.32, first 52 bytes of MODBUS message data.

P89.01 does not appear in the MODBUS message, it is used to identify the type of packet being transferred between the CDC and the Ethernet expansion bus board.

The MODBUS header format remains the same for transmit and receive messages.

The MODBUS data format differs between transmit and receive messages as well as being dependent upon the function code displayed in the low byte of P89.05.

The receive data bytes align on word boundaries, meaning that the data word does not span a parameter, i.e. a received data word is contained in exactly one P89.xx parameter.

The transmit data bytes do not always align with word boundaries, because, in the case of function codes 03 and 04, the first byte of the data response contains the number of bytes of data (P89.06 High).

After that, the words being read appear as the low byte of one parameter and the high byte of the next.

By displaying in hexadecimal, it is much easier to combine these byte pairs to form the contents of the register being read. See tables below.

Field	P-No.	Description	Length	Example
	P89.01	Protocol type (0100h = MODBUS)	2 bytes	
Header	P89.02	Transaction identifier	2 bytes	
	P89.03	Protocol identifier	2 bytes	
	P89.04	Length	2 bytes	
	P89.05 Hi	Unit identifier	2 bytes	
F ^d Code	P89.05 Lo	Function code	2 bytes	
Receive data	P89.06	Starting Address	2 bytes	
	P89.07	Quantity of registers	2 bytes	
	P89.08	Optional data for write function codes	2 bytes	
		Optional data for write function codes	2 bytes	
	P89.32	Optional data for write function codes	2 bytes	

Table 5-16. – Receive Data Format

Field	P-No.	Description	Length	Example	
	P89.01	Protocol type (0100h = Modbus)	2 bytes	0100h	
Header	P89.02	Transaction identifier	2 bytes	D750h	
	P89.03	Protocol identifier	2 bytes	0000h	
	P89.04	Length	2 bytes	0007h	
	P89.05 Hi	Unit identifier	1 byte	01h	
F ^d Code	P89.05 Lo	Function code	1 byte	03h	
Transmit data for F ^d Codes 03 & 04	P89.06 Hi	Data length	1 byte	04h	
	P89.06 Lo	Upper byte of register word 1	1 byte	27h	
	P89.07 Hi	Lower byte of register word 1	1 byte	10h	
	P89.07 Lo	Upper byte of register word 2	1 byte	27h	
	P89.08 Hi	Lower byte of register word 2	1 byte	10h	
				1 byte	
				1 byte	
	P89.0x Lo	Upper byte of register word n	1 byte		
	P89.0y Hi	Lower byte of register word n	1 byte		

Table 5-17. – Response Data Format

Only MODBUS messages that attempt to access addresses in the range 100 to 9999 will be captured.

The MODBUS start address is one less than the menu parameter being accessed e.g. MODBUS address 899 (383 hex) is used to access drive parameter P9.00, this being 900-1⁶.

When viewing the data spy parameters that represent the protocol packet data, it is likely that the displayed data will be constantly changing. In the case where the same protocol message is being transmitted, and no other protocol messages are occurring, this will be because the contents of the protocol message data is changing.

If parameter P9.01 is being monitored (speed feedback), the value displayed will change while the speed is changing. However, if multiple parameters are being monitored, using different protocol requests for each of the monitored parameters, then the response messages will contain different data values for each of the responses.

For example, if, using MODBUS, parameters P9.01 (speed feedback %) and P11.00 (Active Current %) are monitored using separate MODBUS messages, the response messages will be identical except for the two bytes representing the value of the parameter being monitored.

Even in this simple example, to determine the value of the parameter being monitored requires viewing of two adjacent spy parameters to extract the high and low bytes. Clearly there will be uncertainty as to which high and low byte pairs belong together.

In the case of multiple messages containing multiple parameter reads it is impossible to determine the correct values monitored with any degree of certainty. To overcome this uncertainty, a spy freeze capability has been implemented to allow the capturing of spy data to be suspended.

⁶ The above sum is usually transparent to the user; i.e. the MODBUS master will refer to address 900 when accessing parameter P9.00.

To freeze the display, set P89.00 to be any value in the range 86.00 to 86.99 (except the values in the range 86.20 to 86.23 and 86.70 to 86.73). In order to capture data, P89.00 must have been one of the values 86.20 to 86.23 or 86.70 to 86.73 before freezing. Be aware that the frozen data may consist of parts of two consecutive MODBUS messages.

It is recommended that the unfreeze-freeze process be repeated until the MODBUS message of interest is captured.

The user's knowledge of the protocol in use, together with some expectation of the likely response, is relied upon to determine whether the captured data is that of one or two messages.

6. ENGINEERING DATA SHEET FILE

6.1 INTRODUCTION

Some protocol master units require an electronic data sheet in order to determine the capabilities of the slave unit. These capabilities are described in a file provided by the unit's manufacturer known as a EDS (Electronic Data Sheet) file, this is usually a simple text format file. The table below details the type of EDS file required for each supported protocol.

Protocol	File	Extension
MODBUS TCP	None required	Not applicable
EGD	None required	Not applicable

Table 6-1. – EDS File

Ensure the correct EDS file is used for the appropriate protocol.

7. COMMISSIONING

WARNING

- **This equipment may be connected to more than one live circuit. Disconnect ALL supplies before working on the equipment.**
- **Wait at least 6 minutes after isolating supplies and check that the voltage between DC+ & DC- has reduced to safe level before working on this equipment.**

7.1 MECHANICAL CHECKS

Check that the Ethernet Interface board has been installed in accordance with the instructions given in Section 4.. Check particularly for the following:

- correct connector and cable types;
- suitable cable length;
- segregation of wiring to minimise electromagnetic interference;

7.2 TOOLS & EQUIPMENT

The only equipment required for commissioning the Ethernet link is either an Drive Data Manager™ (Keypad) MVS3000-4001 or Drive Coach MVS3004-4001 with an associated host PC.

No special tools are required to commission the Ethernet link.

7.2.1 Ethernet Configuration

The MV3000e drives are configured, controlled and monitored by reading and writing drive parameter values. This principle extends to the Ethernet Interface Module when it is fitted. Drive parameters are accessed by either:

- using the Drive Data Manager™ (Keypad);

OR

- The PC programming package Drive Coach using Serial Link communications.

Use of the Drive Data Manager™ (Keypad) and serial links for the drive is explained in the MV3000e Technical Manuals.

Section 5 of this manual describes how to configure and control the Ethernet connection, using the drive parameters. To aid configuration of the Ethernet connection, working sheets are provided in Appendix A.

The following flow charts show the recommended sequence for commissioning the Ethernet Interface for a MODBUS protocol application.

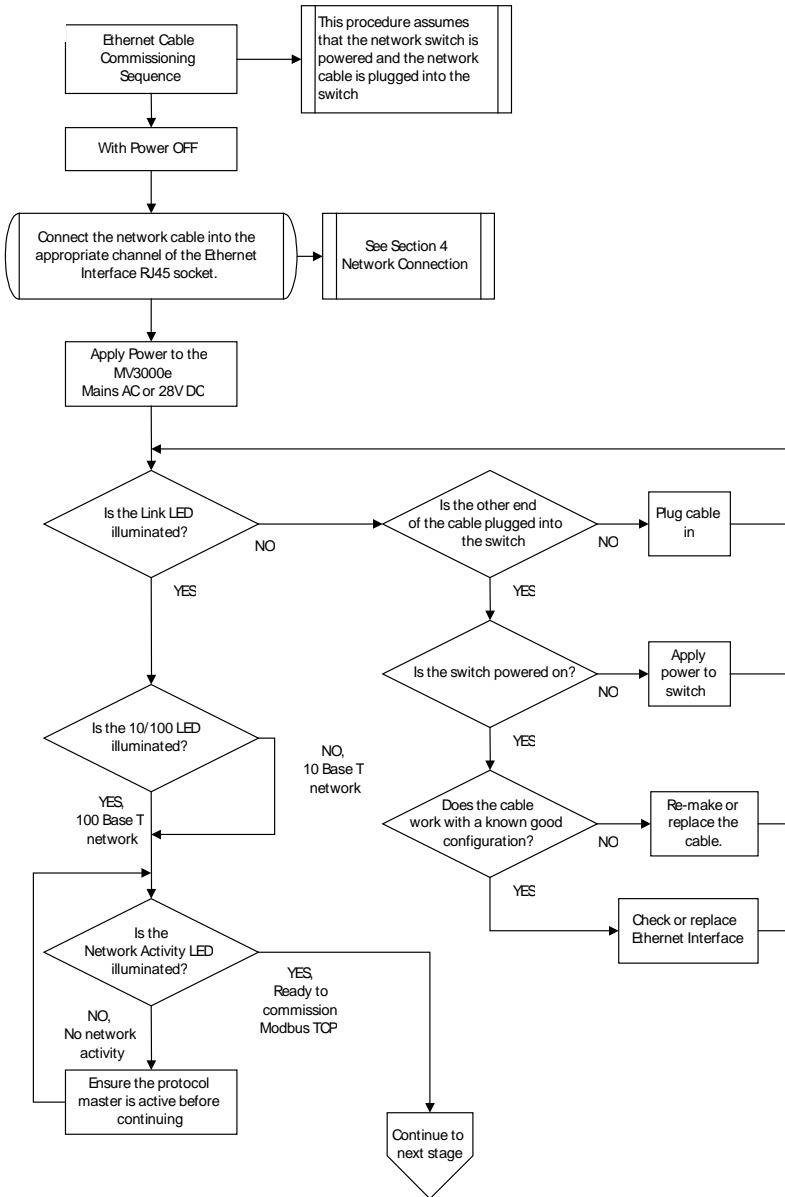

Figure 7-1. – Commissioning Sequence for Ethernet Connection

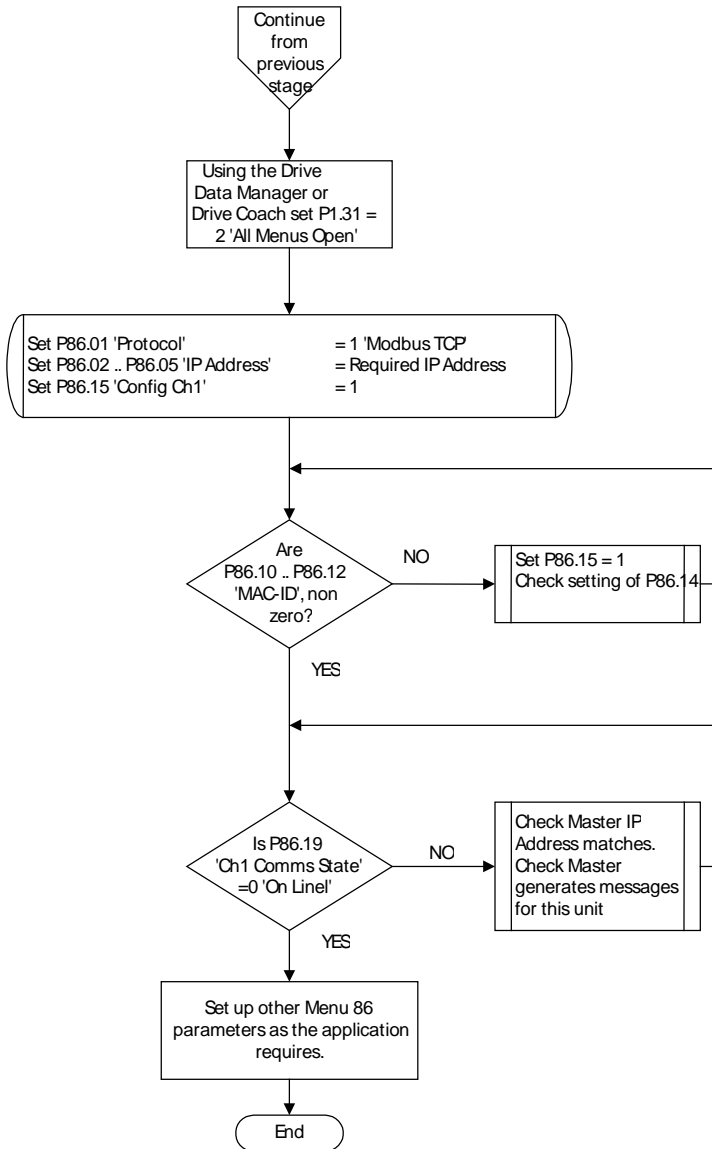

Figure 7-2. – Commissioning Sequence for MODBUS TCP

7.3 PROTOCOL SETUP PROCEDURE

Commissioning of the selected Ethernet protocol requires that the Ethernet cable is connected and active. Refer to Figure 7-2 for an overview of the protocol commissioning sequence.

Perform the following steps:

- a) Ensure P1.31 contains a value of 2.

Menu 86 should now be visible, signifying that the Drive has detected the presence of the Ethernet Interface. The presence of parameters P86.51 onward signifies the presence of a Dual Channel Ethernet Interface.

- b) Set P86.01 to the desired protocol, e.g. 1 for MODBUS TCP.
- c) Set P86.02 through to P86.05 to the IP address that matches the IP address expected by the protocol master. Set P86.15 to 1 to configure the Ethernet channel. The parameter will return to zero after completing the configuration.
- d) Check P86.10 through P86.12 display a MAC-ID of the form 0080h, 6Cxxh, xxxh, where xx signifies a unique value for that Ethernet channel.
- e) Check P86.19 displays 'On Line'. If not, use the commissioning flow chart to investigate why not.
- f) Once P86.19 displays 'On Line', set the other parameters as required for the application.

7.4 ETHERNET RJ45 CONNECTOR INDICATOR LEDs

The Ethernet board uses a RJ45 connector with integral status LEDs. These are not visible from the outside of the drive, but are visible on the edge of the board when the Drive control door is open. They are viewed end-on as shown in Figure 7-3 and have meanings as shown in Table 7-1.

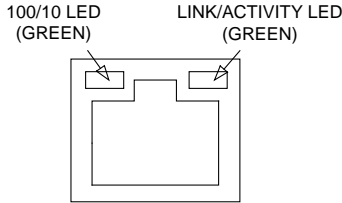

Figure 7-3. – RJ45 Status LEDs On The Ethernet Board

LED	State	Description
Link/Activity	Off	Disconnected cable or no link
	On	Link Established
	Flashing	Network traffic present
100/10	Off	10Mbps Communication speed or no link
	On	100Mbps Communication speed

Table 7-1. – LED Indication Meaning

Parameter P86.19 (P86.69) displays the state of the communications without opening the drive to view the LEDs, see Section ????.

7.5 ETHERNET CHANNEL INDICATOR LEDs

The Ethernet board uses a 4 LED indicator module to provide status indication of each Ethernet channel. These are not visible from the outside of the drive, but are visible on the edge of the board when the Drive control door is open. They are viewed end-on as shown in Figure 7-4 and have meanings as shown in Table 7-2.

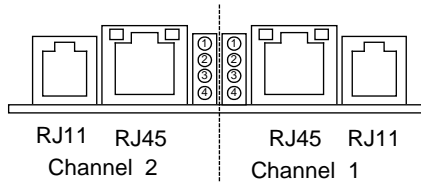

Figure 7-4. – Channel Status LEDs On The Ethernet Board

For approximately one second after power-on, whilst the Ethernet Interface is initialising, the meaning of the status LEDs is given in Table 7-2. – LED Indication Meaning During Bootstrap.

After initialisation of the Ethernet Interface, the meaning of the status LEDs is given Table 7-3. – LED Indication Meaning After Bootstrap.

State	LED1	LED2	LED3	LED4	Description
1	Off	Off	Off	Off	No power
2	Off	Off	On	On	Channel held in reset
3	Off	On	On	On	Bootng performing ram test (0.1 seconds).
4	On	Off	On	On	Bootng, polling serial port (0.5 seconds).
5	On	On	On	On	Bootng
6	On	Blink	On	On	Bootng complete, polling serial port, no firmware loaded
7	Off	Blink	On	On	Bootng from serial port
8	Off	On	On	On	Erasing or programming FLASH memory
9	Off	Off	Off	Blink	Booted and software healthy
10	Off	Off	Off	X	Calling DHCP server
11	On	Off	Off	Blink	Healthy & protocol configured
12	On	On	Off	Blink	Healthy, configured & connected
13	X	X	On	X	Software fault detected

Table 7-2. – LED Indication Meaning During Bootstrap

The normal sequence is states 1, 2, 3, 4, 5 and 9. State 9 indicates the firmware has completed its boot-up procedure and is healthy and ready to accept commands from the CDC software.

State 10 indicates that a DHCP Server call is being made. State 11 indicates the channel has had a successful protocol configuration command from the CDC software. State 12 occurs when a protocol connection has been made.

State 6 indicates that there is no firmware loaded.

States 7 and 8 will occur during a firmware update, i.e. when a connection is made between a PC and the RJ11 connector, and special firmware update software is running on the PC.

State 13 may occur if a firmware update has failed, or if there is a fault on the board. ['X' = 'any state'.]

LED	Description
1	A protocol has been configured
2	Protocol connection established ⁷
3	Firmware Fault
4	Flashing indicates firmware operational

Table 7-3. – LED Indication Meaning After Bootstrap

7.6 VERIFYING DATA CONTENTS

Once the Ethernet protocol has been commissioned, the next step should be to verify the data being sent to or from the protocol master.

For simple applications, viewing the data item on the drive (e.g. a reference) or the master (e.g. a monitor point) may be sufficient to confirm correct data.

For more complex applications, the use of the data spy (see Section 5.5) is a way of confirming the data values at the point of entry or exit to or from the drive. These should correspond to the producer or consumer at the source or destination end of the Ethernet network.

Note: As the data spy values are displayed in hexadecimal, it may be useful to have a hex to decimal utility, such as a scientific calculator.

⁷ This is only true for MODBUS TCP. For EGD this LED is not illuminated as UDP is a 'connectionless' protocol.

8. MAINTENANCE

8.1 GENERAL GUIDANCE

When the Ethernet Interface is utilised in an MV3000e Drive, its maintenance requirements are included with maintenance of the drive, described in the T1676 MV3000e Getting Started Manual.

The drive maintenance consists generally of checking for ingress of dust and moisture, and checking for security of electrical connections. The latter checks should include all the cables and connectors used for Ethernet connections.

8.2 FIRMWARE REVISIONS

Firmware revisions for the Ethernet Interface software used in the MV3000e Drive are available from GE Power Conversion. Contact GE Power Conversion for details at the Customer Support telephone number listed at the end of this manual.

9. DIAGNOSTICS

9.1 FAULTS

If a link, that was previously working, stops working then one of the two error codes may be displayed depending upon the setting of P86.17 (P86.67).

9.2 ETHERNET WARNING FAULT CODES

Table 9-1 shows the warning fault codes displayed in the drive warnings table, if the Ethernet link is not healthy, and P86.17 (P86.67), Ch1 (Ch2) loss action has been set to "warning".

Fault Code	Name	Description
143	Ethernet Ch1 Loss	Channel 1 has not received the appropriate protocol message (see P86.34) within the time-out specified by P86.33.
144	Ethernet Ch2 Loss	Channel 1 has not received the appropriate protocol message (see P86.84) within the time-out specified by P86.83.

Table 9-1. – Warning Fault Codes

9.3 ETHERNET TRIP FAULT CODE

Table 9-2 shows the trip fault code displayed in the drive trip tables when the Ethernet link is not healthy, and P86.17 (P86.67), action on loss, has been set to "trip".

Fault Code	Name	Class	Description
220	Ethernet Ch1 Loss	R	Channel 1 has not received the appropriate protocol message (see P86.34) within the time-out specified by P86.33.
221	Ethernet Ch2 Loss	R	Channel 1 has not received the appropriate protocol message (see P86.84) within the time-out specified by P86.83.

Table 9-2. – Trip Fault Code

A = Auto re-settable trip

R = Manually re-settable trip

S = System trip

N = Non re-settable trip

9.4 STATUS FLAGS

Two status flags are available, if required, for use within the drive's control logic:

Status Flag Number	Value to be used as CF or DIGOUT Source	Description
SF87	2.087	Ethernet Interface Channel 1 Healthy
SF88	2.088	Ethernet Interface Channel 2 Healthy

Table 9-3. – Status Flags

9.5 PROTOCOL STATUS P86.19 (P86.69)

This parameter displays the state of the communications; see Table 5-9.

9.6 SPARES & RE-ORDER INFORMATION

The interface does not contain any user replaceable parts and must be returned to the manufacturer for repair. Whole units should be kept for spares.

Please contact customer support, or your local agent for details.

The order numbers for the Ethernet Interface Modules are:

- Single Channel MVS3012-4001
- Dual Channel MVS3012-4002

10. APPENDIX A

10.1 ETHERNET CONFIGURATION TABLES

This appendix includes a set of tables (Table 10-1 to Table 10-9) which enable a Fieldbus over Ethernet network to be configured. Each table includes an example of a typical configuration shown in the shaded rows of the table.

It is suggested that a user copies all the pages from this appendix and uses them to configure the required network.

It is also recommended that the completed tables are copied and retained safely as records of the network configuration.

No.	Param.	Fallback Value	Description
Ch 1 1	P86.25	0	Used for speed reference
Ch 1 1	P86.25		
Ch 1 2	P86.26		
Ch 2 1	P86.75		
Ch 2 2	P86.76		

Table 10-1. – Reference Word Usage

No.	Param.	Fallback Value	Description
Ch 1 1	P86.27	0000 0000 0000 0000	Used for speed reference
Ch 1 1	P86.27		
Ch 1 2	P86.286		
Ch 2 1	P86.77		
Ch 2 2	P86.78		

Table 10-2. – Control Word Usage

No.	Param.	Points To Param.	Scale	Function
1	P42.00	86.25	10000	Speed Reference
1	P42.00			Speed Reference
2	P42.02			Speed Reference
3	P42.04			Reference Sequencer
4	P42.06			PID Set-point
5	P42.08			PID Feedback
6	P42.10			Trim Reference
7	P42.12			Speed Trim Reference
8	P42.14			Torque Reference
9	P42.16			Torque Limits
10	P42.18			Torque Limits
11	P42.20			Temperature Compensation Scale
12	P42.22			Flux Limit
13	P42.24			Current Limit
14	P42.26			Torque/Magnet. Current
15	P42.28			Torque/Magnet. Current
16	P42.30			Position Reference
17	P42.32			Position Reference
18	P42.34			Tacho Feedback
19	P42.36			Variable Volts Boost
20	P42.38			Reference Shaper
21	P42.40			AEM V dc Reference
22	P42.42			AEM Active Current Reference
23	P42.44			AEM Active Current Negative Limit
24	P42.46			AEM Active Current Positive Limit
25	P42.48			AEM Reactive Current Reference
26	P42.50			AEM Reactive Current Positive Limit
27	P42.52			AEM Reactive Current Negative Limit
28	P42.54			Proportional DB Reference
29	P42.56			P PID Setpoint
30	P42.58			P PID Feedback
31	P42.60			Feed Forward Source
32	P42.62			Positive Limit Source
33	P42.64			Negative Limit Source
34	P42.66			Q PID Setpoint
35	P42.68			Q PID Feedback
36	P42.70			Feed Forward Source
37	P42.72			Positive Limit Source
38	P42.74			Negative Limit Source

Table 10-3. – Menu 42: Reference Pointers

Bit	Control Flag Number	Fallback Value	Description
0	5.300	0	Bit 0 mapped to Stop flag
0	5.300		
1	5.301		
2	5.302		
3	5.303		
4	5.304		
5	5.305		
6	5.306		
7	5.307		
8	5.308		
9	5.309		
10	5.310		
11	5.311		
12	5.312		
13	5.313		
14	5.314		
15	5.315		

Table 10-4. – Ch1 Control Word 1 Bit Usage: P86.27

Bit	Control Flag Number	Fallback Value	Description
0	5.316	0	Bit 0 mapped to Stop flag
0	5.316		
1	5.317		
2	5.318		
3	5.319		
4	5.320		
5	5.321		
6	5.322		
7	5.323		
8	5.324		
9	5.325		
10	5.326		
11	5.327		
12	5.328		
13	5.329		
14	5.330		
15	5.331		

Table 10-5. – Ch1 Control Word 2 Bit Usage: P86.28

Bit	Control Flag Number	Fallback Value	Description
0	5.332	0	Bit 0 mapped to Stop flag
0	5.332		
1	5.333		
2	5.334		
3	5.335		
4	5.336		
5	5.337		
6	5.338		
7	5.339		
8	5.340		
9	5.341		
10	5.342		
11	5.343		
12	5.344		
13	5.345		
14	5.346		
15	5.347		

Table 10-6. – Ch 2 Control Word 1 Bit Usage: P86.77

Bit	Control Flag Number	Fallback Value	Description
0	5.348	0	Bit 0 mapped to Stop flag
0	5.348		
1	5.349		
2	5.350		
3	5.351		
4	5.352		
5	5.353		
6	5.354		
7	5.355		
8	5.356		
9	5.357		
10	5.358		
11	5.359		
12	5.360		
13	5.361		
14	5.362		
15	5.363		

Table 10-7. – Ch 2 Control Word 2 Bit Usage: P86.78

Bit	Param. No.	Control Flag No.	Description
0	P41.00	2.001	Bit 0 mapped to Stopped flag
0	P41.00		
1	P41.01		
2	P41.02		
3	P41.03		
4	P41.04		
5	P41.05		
6	P41.06		
7	P41.07		
8	P41.08		
9	P41.09		
10	P41.10		
11	P41.11		
12	P41.12		
13	P41.13		
14	P41.14		
15	P41.15		

Table 10-8. – Programmable Status Word 0

Bit	Param. No.	Control Flag No.	Description
0	P41.16	2.001	Bit 0 mapped to Stopped flag
0	P41.16		
1	P41.17		
2	P41.18		
3	P41.19		
4	P41.20		
5	P41.21		
6	P41.22		
7	P41.23		
8	P41.24		
9	P41.25		
10	P41.26		
11	P41.27		
12	P41.28		
13	P41.29		
14	P41.30		
15	P41.31		

Table 10-9. – Programmable Status Word 1

11. APPENDIX B

11.1 INDEX

This subject index applies to the English Edition of the T2034EN Technical Manual Technical Manual for the MV3000e Ethernet Interface for MV3000e Drives.

The indexes are prepared with word-by-word alphabetisation and are presented with page numbers for subject location.

A			
acronyms.....	6		
attribute(s)			
for drive parameters	31		
B			
Backup Channel	50		
C			
cable(s)			
clean.....	30		
dirty.....	30		
segregation	30		
strain relief.....	30		
CAT5.....	28		
CDC.....	6		
CFSRC	6		
clean wiring.....	30		
commissioning	65		
Communications loss	42		
Communications Status	46		
Configuration	41		
Configuration tables			
Ethernet	72		
connection diagrams.....	29		
Consume Action	50		
control flag			
source.....	6		
Control Words.....	48		
customer support	69		
Cyclic Redundancy Check.....	6		
		D	
Data errors	47		
Data refresh rate	15		
data spy	68		
menu	57		
Data spy.....	57		
definitions	6		
DHCP	6, 52		
diagnostics.....	70		
Ethernet trip fault code.....	70		
Ethernet warning fault code	70		
faults.....	70		
dirty wiring	30		
Drive scan rates.....	15		
		E	
earthing			
for Ethernet.....	30		
EDS			
File	60		
EGD Data Port	19		
electrical noise	30		
electromagnetic			
interference.....	30		
Error Reporting.....	47		
Ethernet connector	15, 28		
Ethernet Global Data.....	19		
External Wiring.....	30		

F	
Fallback Action	43
Fallback Control Words.....	49
Fallback Reference Words	49
Fieldbus device	38
firmware	69
firmware revisions	69
FS6	
G	
Gateway address	52
General description	13
GND.....	6
ground.....	6
H	
h 6	
Hardware identifier.....	38
I	
Installation	21
Installation procedure	
DELTA systems	26
Microcubicle™ drives	22
IP address.....	39, 52
L	
LED descriptions.....	66, 67
Loss of reference.....	42
M	
MAC-ID.....	6, 40
maintenance	69
firmware revisions	69
general guidance.....	69
Master Node	7
Menu 86 description.....	38
menu(s)	
89 – Data Spy	57
Modbus Function Codes	16
Modbus TCP/IP Port.....	16, 39
N	
Node address	40

P	
parameter(s)	
attributes	31
Parameters.....	31
peer-to-peer.....	7
PIB	6
producer/consumer network.....	7
Protocol.....	38
Protocol terms	7
R	
Receipt of equipment	21
Reference Words	48
Run on power up.....	41
S	
segregation	30
Slave Node	7
Spares.....	71
Src	6
Storage	21
Subnet mask.....	39
T	
terminology.....	6
Timeout	49
Timeout Scope	50
trip	
fault code	70
Trip and warning codes	42
V	
VSD	6
W	
warning(s)	
energy discharge	28
fault codes.....	70
in drive tables.....	70
multiple circuits.....	28

12. APPENDIX C

12.1 BLOCK DIAGRAM

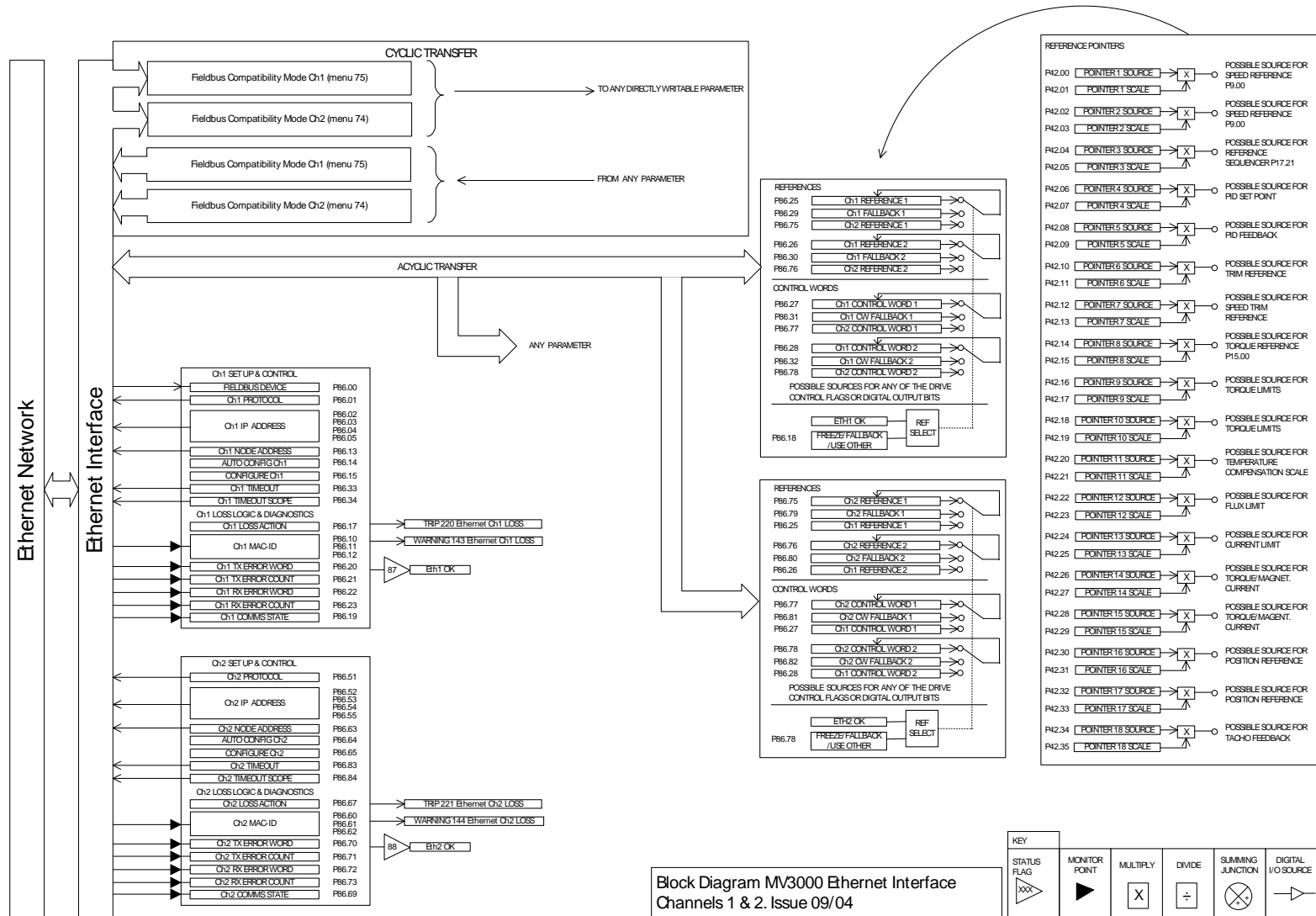

Figure 12-1. – Block Diagram

13. CONTACT DETAILS FOR SALES, SERVICE & SUPPORT

www.avidcontrolsinc.com

Please refer to your local technical support centre if you have any queries about this product.

Technical Support Centre

USA

Avid Controls, Inc.
41261 Park 290 Dr
Waller, TX 77484 USA
Tel: +1(281)640-8600
Fax: +1(281)640-8605

For all parts enquiries:

Email: info@avidcontrolsinc.com