

Screened Ribbon Cables for MV DELTA's

Part Number : MVC3007-4001, MVC3007-4002 & MVC3007-4003

Features / Specifications :

- Provides a screened ribbon cable between the MV3000e Controller and the DELTA Transistor Bridge for improved noise immunity.
- Allows fitting to existing applications.
- Simple to fit.

Box Contents

	Item	Description	Quantity per assembly		
			MVC3007-4001	MVC3007-4002	MVC3007-4003
1)	41Y8215/10	Short, screened ribbon cable	1	1	1
2)	41Y8215/20	Medium, screened ribbon cable	0	1	1
3)	41Y8215/30	Long, screened ribbon cable	0	0	1
4)	51Y1771/01	Controller earthing plate	1	1	1
5)	40001/300	M5 Nut	6	6	6
6)	40065/300	M5 spring washer	6	6	6
7)	40221/250	M4 × 6 Taptite screw	1	2	3
8)	DPL0448/XX	Label for ribbon cables	2	4	12
9)	T1943EN	Instruction sheet	1	1	1

Related Documents

Failure to comply with any of the general requirements for installation, operation and maintenance provided in the technical manuals will significantly increase the risk of maloperation, fire or electric shock.

Refer to T1689, MV3000e Delta Technical Manual or T1693 MV3000e Liquid Cooled DELTA Manual for information on the connections between the DELTA Transistor Bridge and the MV3000e Controller.

Introduction

This Instruction Sheet shows how to fit and earth screened ribbon cables between the MV3000e Controller and DELTA transistor bridges.

MV3000e Controllers have three earth studs incorporated into the steelwork to allow earthing of the screened ribbon cables. As older versions of the MV3000e Controller do not have these earth studs, an earthing plate is provided in the kit.

Screened Ribbon Cables for MV DELTA's

Tool Requirements

Medium sized Pozi Drive (Cross head) screwdriver.

M5 Socket Drive or Spanner.

1 MV3000e Controller (MVC3001-4001) connections

1.1 If the MV3000e Controller is not fitted with earth studs similar to those shown in Figure 1 :

- (i) Remove and retain the two quantity, M4 × 6 long 'Taptite' screws from the positions adjacent to PL8 and PL DELTA 1. These are labelled as "A" and "B" in Figure 1.
- (ii) Locate the metal bracket supplied as indicated in Figure 1, and fix using the two screws removed in section 1.1 (i).

Remove and retain the two M4 x 6 long "Taptite" screws at the positions marked "A" and "B". On some models a third screw may be fitted between these positions – this should be removed and discarded.

Locate the metal plate (with the six studs) onto the control assembly as shown.

Refit two "Taptite" screws at positions "A" and "B" to secure the plate.

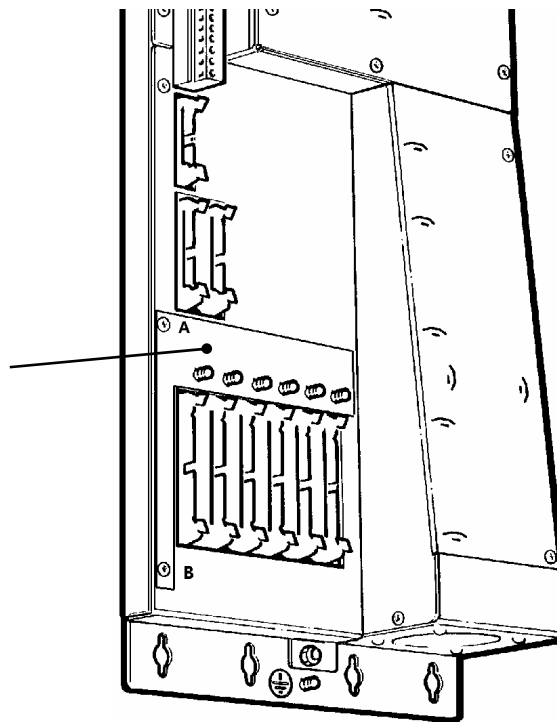

Figure 1 : Assembly of earthing plate to early model MV3000e Controller

- 1.2 If not already done, install the MV3000e Controller following the guidelines in the relevant instruction manual.
- 1.3 Fit the screened ribbon cable(s) into the correct connector(s), PL2 to PL7 as applicable. Ensure that the end of the ribbon cable that is connected to the controller has the black jacket all the way up to the connector, as shown in Figure 2.
- 1.4 Locate the M5 ring crimp on the flying lead over the stud and secure using the spring washer and nut supplied loose in the bag.

See Figure 2 for a fully fitted MV3000e Controller.

Screened Ribbon Cables for MV DELTA's

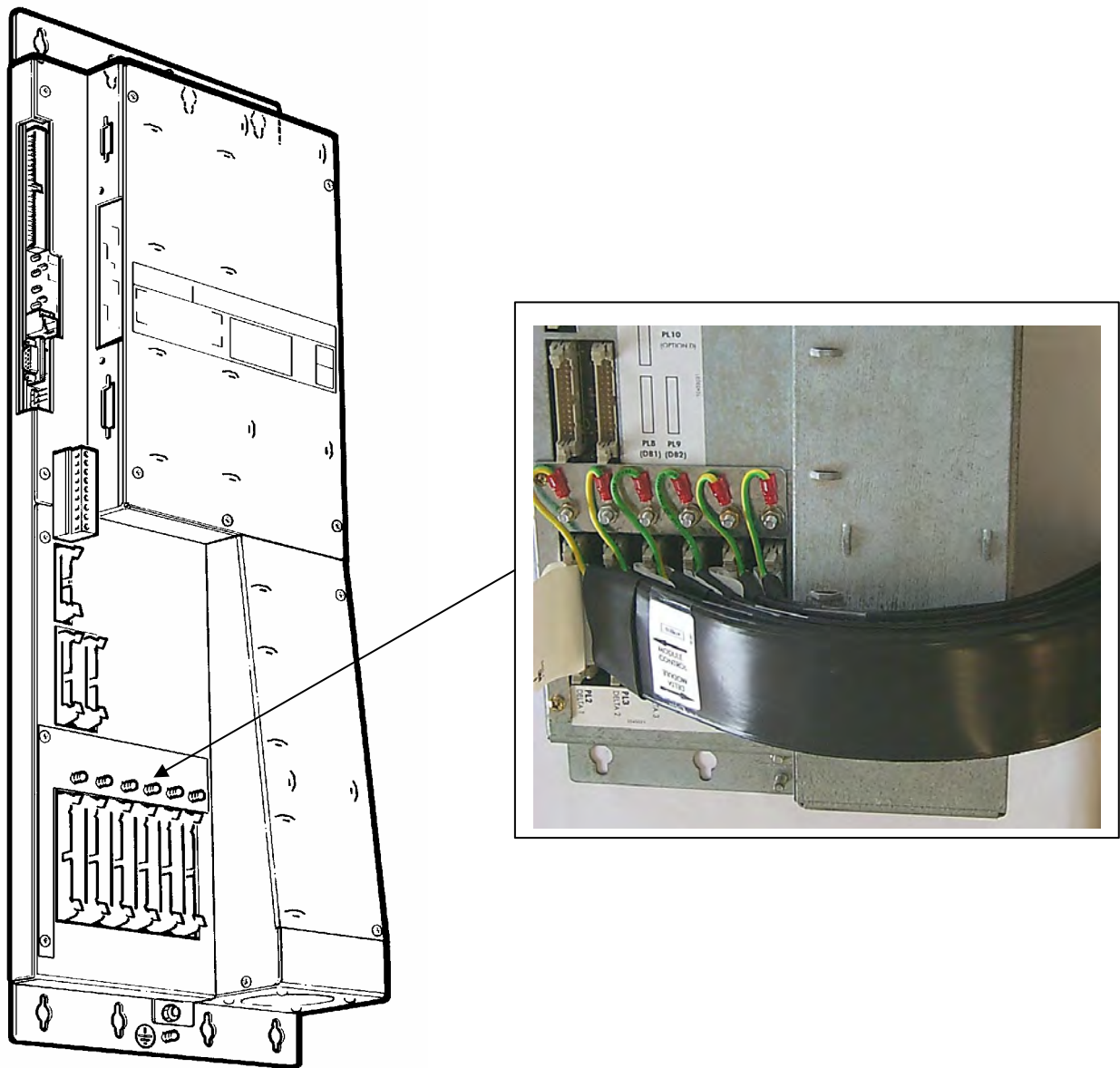

Figure 2 : Completed assembly of 6 screened ribbon cables into MV3000e Controller
(and showing use of the earthing plate)

Screened Ribbon Cables for MV DELTA's

2 Connections for MV3000e Air Cooled DELTA Transistor Bridge.

(MVD282–4501, MVD300–4601, MVD377–4501)

Note: These fitting instructions apply to the transistor bridge when fitted into a suitable enclosure, following the recommended guidelines.

- 2.1 Refer to Figure 3 and fit the screened ribbon cable into PL1 on the DELTA Transistor Bridge Interface Board. Ensure that this end of the screened ribbon cable has approximately 280 mm of ribbon cable un-screened. Route the ribbon around onto the outside face of the insulating cover, and up towards the top of the cubicle using the retaining clips to hold the cable.
- 2.2 Locate the M4 ring crimp on the flying lead to the earthing point, at the position indicated in Figure 3. Secure using the M4 × 6 "Taptite" screw supplied loose with the screened ribbon cables.
- 2.3 Using the ribbon cable labels provided, attach the relevant labels to either end of the screened ribbon cable. These labels will indicate the Plug Number (on the DELTA Controller) and the DELTA Bridge Number (of the transistor bridge).

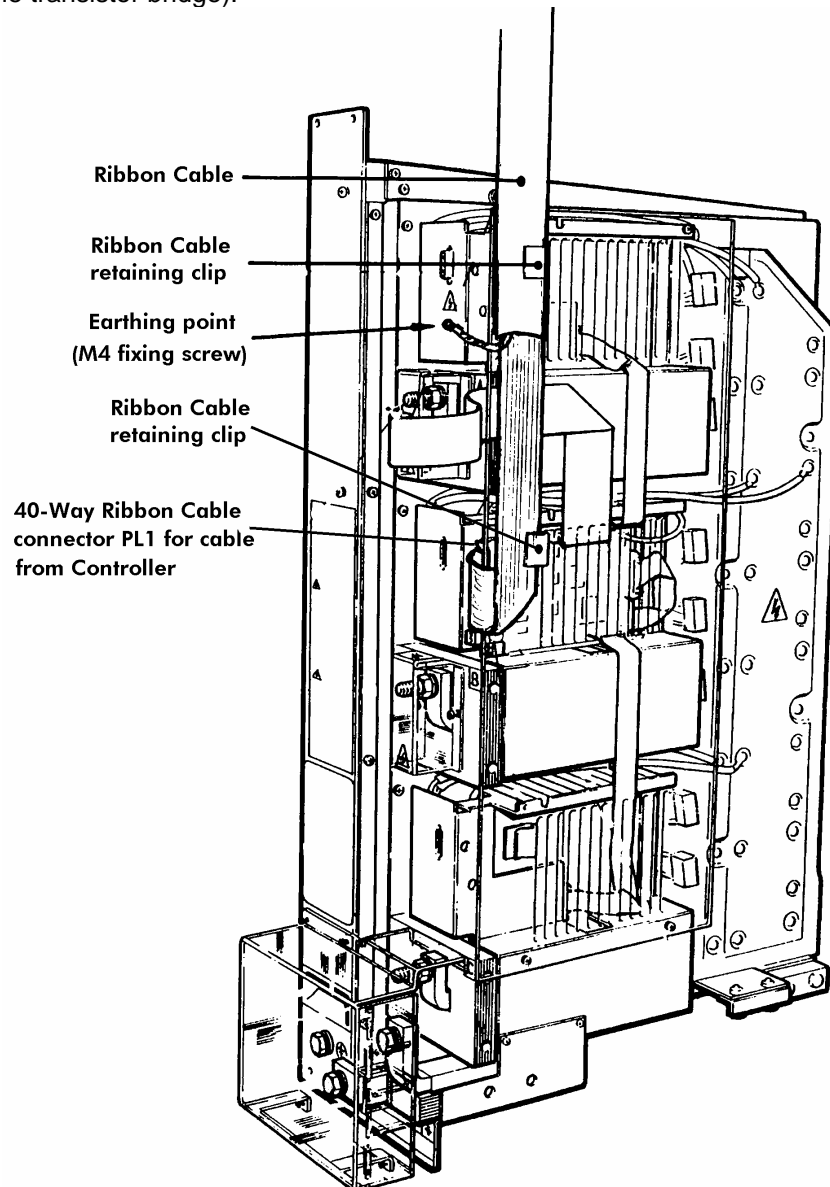

Figure 3 : Routing and fitting of Screened Ribbon Cable to an Air Cooled DELTA Module

Screened Ribbon Cables for MV DELTA's

3 Connections for MV3000e Liquid Cooled DELTA Transistor Bridge.

(MVDL643–4701, MVDL771–4501)

Note: These fitting instructions apply to the transistor bridge when fitted into a suitable enclosure, following the recommended guidelines.

- 3.1 Remove and retain the M4 × 10 long screw that holds the SMPS mounting plate onto the vertical support. Labelled as 'C' in Figure 4.
- 3.2 Fit the screened ribbon cable into PL1 on the Liquid Cooled DELTA Transistor Bridge Interface Board. Ensure that this end of the screened ribbon cable has approximately 280 mm of ribbon cable un-screened. Route the ribbon cable up the metal-work and towards the top of the cubicle.
- 3.3 Locate the M4 ring crimp on the flying lead at the fixing indicated as 'C'. Secure using the M4 × 10 screw.
- 3.4 Using the ribbon cable labels provided, attach the relevant labels to either end of the screened ribbon cable. These labels will indicate the Plug Number (on the MV3000e Controller) and the DELTA Bridge Number (of the transistor bridge).

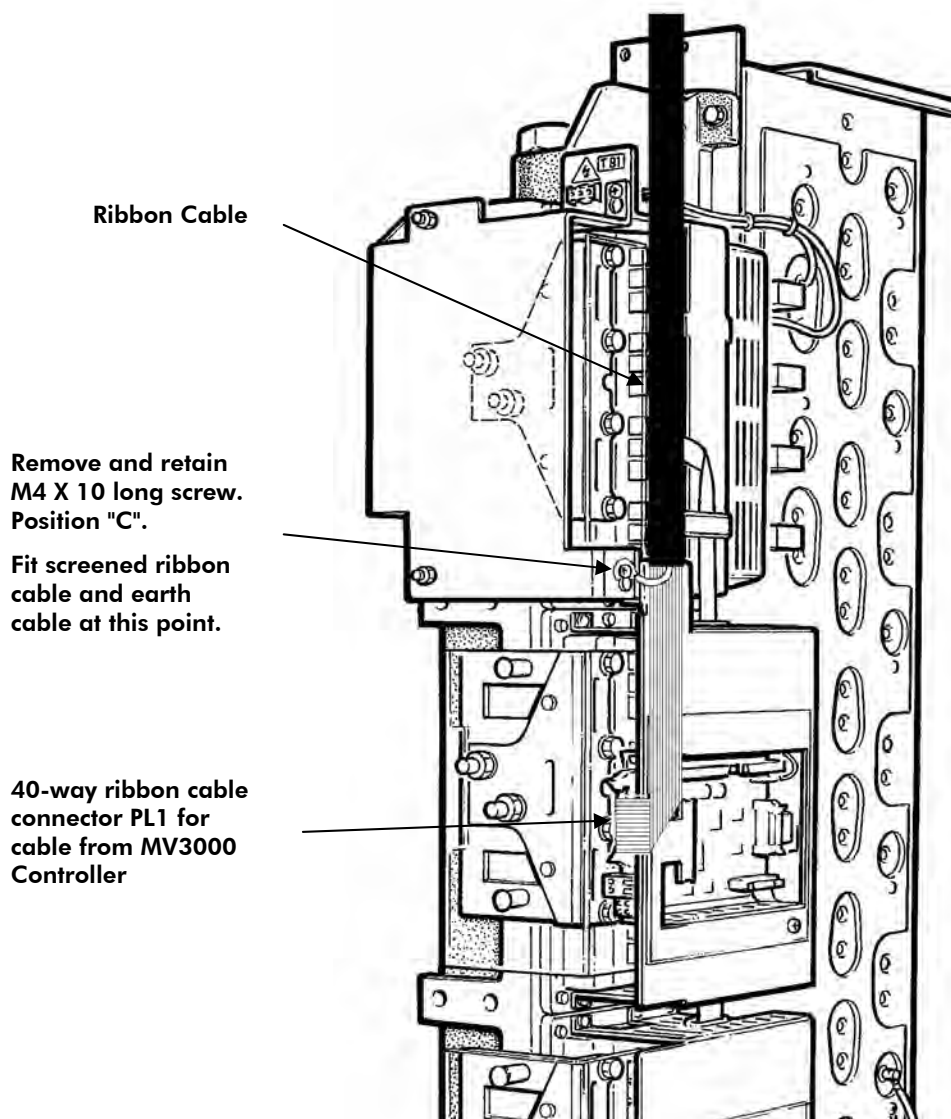

Figure 4 : Routing and fitting of Screened Ribbon Cable to MV Liquid Cooled DELTA Module

Screened Ribbon Cables for MV DELTA's

Avid Controls, Inc.
41261 Park 290 Dr
Waller, TX 77484
+1 (281) 640-8600
Fax +1 (281) 640-8605
info@avidcontrolsinc.com
www.avidcontrolsinc.com

Customer Support and Training

Please refer to your local technical support centre if you have any queries about this product. Contact telephone numbers are shown on this page.