

REV 14
September 25th, 2023

Avid Controls Inc.
41261 Park 290 Drive, Waller, TX 77484, USA
info@avidcontrolsinc.com
(+1) (281) 640-8600

AVID Controls Inc. pursues a policy of continuous product improvement and innovation. This may not be the latest revision of this publication and may not reflect all current product changes. Contact AVID Controls Inc. for the latest revision of this data sheet and information on other product enhancements.

Intentionally Blank

Contents

| | |
|--|----|
| 1. Introduction | 4 |
| 2. WARNINGS | 4 |
| 3. Specification..... | 5 |
| 3.1 Model Numbers | 5 |
| 3.2 Electrical – Power Section..... | 6 |
| 3.3 Electrical – Control & Interface Section | 7 |
| 3.4 Cooling | 8 |
| 3.5 Environmental..... | 10 |
| 3.6 Mechanical..... | 11 |
| 4. High Voltage / Power Connections..... | 12 |
| 5. Low Voltage / Control Connections..... | 12 |
| 5.1 Overview..... | 12 |
| 5.2 Plugs for TB3, TB4 & TB5 | 13 |
| 5.3 Shipping/Handling Protector for 40-Way Ribbon, PL2 | 14 |
| 5.4 TB3 – Auxiliary Power Supply | 15 |
| 5.5 TB4 – Analog Outputs..... | 15 |
| 5.6 TB5 – Solid State Relays..... | 16 |
| 5.7 TB6 – RS485 | 16 |
| 5.8 PL2 – Controller Connection..... | 17 |
| 6. User Selectable Options | 18 |
| 6.1 Overview..... | 18 |
| 6.2 Over-volts Trip Mode (SW1 to SW4)..... | 18 |
| 6.3 Analog Output Mode (SW5 and SW6)..... | 19 |
| 6.4 Compatibility Rating Mode (SW7) | 20 |
| 6.5 MODBUS Address Setup Switches..... | 21 |
| 6.6 MODBUS Sample Mode (Newer Units Only)..... | 21 |
| 6.7 Unused Switches..... | 21 |
| 7. LED’s and Fault Indication | 22 |
| 7.1 Discrete RED & GREEN LED’s..... | 22 |
| 7.2 Discrete YELLOW LED (Newer Units Only) | 22 |
| 7.3 Program Version Display | 22 |
| 7.4 LED Feedback Indication..... | 23 |
| 7.5 Fault Codes | 24 |
| 7.6 Internal Cooling Fan Fault..... | 26 |
| 8. MODBUS Communications..... | 27 |
| 8.1 Introduction..... | 27 |
| 8.2 MODBUS_TIMER..... | 27 |
| 8.3 Diagnostic Data | 27 |
| 8.4 MODBUS Sample Mode..... | 30 |
| 9. Document Revision History | 30 |

AVID CONTROLS and the  logo are registered trademarks of Avid Controls Inc.
MODBUS is a registered trademark of Schneider Automation Inc.

1. Introduction

- The AEI900L/AEI1000L/AEI1250L and AEI1400L inverter modules are high reliability liquid cooled inverter modules with nominal ratings from 900A to 1250A at 690Vac and 1400A at 600Vac for use with MV3000 AC drives, controlled by the Common Drive Controller (CDC).
- The AEI900L can also be operated at a nominal rating of 800A for compatibility purposes.
- Its significant technical attributes are:
 - Sintered solder-free IGBT modules for extended life operation
 - Ruggedized IGBT die for improved environmental robustness
 - Reduced internal voltage overshoot
 - More robust, fully digital gate driver
 - IGBT modules are fully sealed for protection from condensation
 - Continuous, accurate monitoring of IGBT silicon temperature under all operating conditions

2. WARNINGS

- This equipment may be connected to more than one live circuit.
- Wait at least 8 minutes after isolating supplies and check that the voltage between DC+ and DC- has reduced to a safe level before working on the equipment.
- Surfaces on the coolant pipes can reach high temperatures and remain hot for some time after power is removed.
- Ensure that all coolant has cooled to a safe temperature and the equipment is suitably drained and isolated before the external pipework is disconnected from the equipment.
- Unit is heavy: 105kg (231 lb.) for the AEI900L / AEI1000L and 125kg (276 lb.) for the AEI1250L/AEI1400L

3. Specification

3.1 Model Numbers

- All Avid Extreme Inverter products use a consistent Model Number scheme:

AEI xxx c – 000000 – mm – g

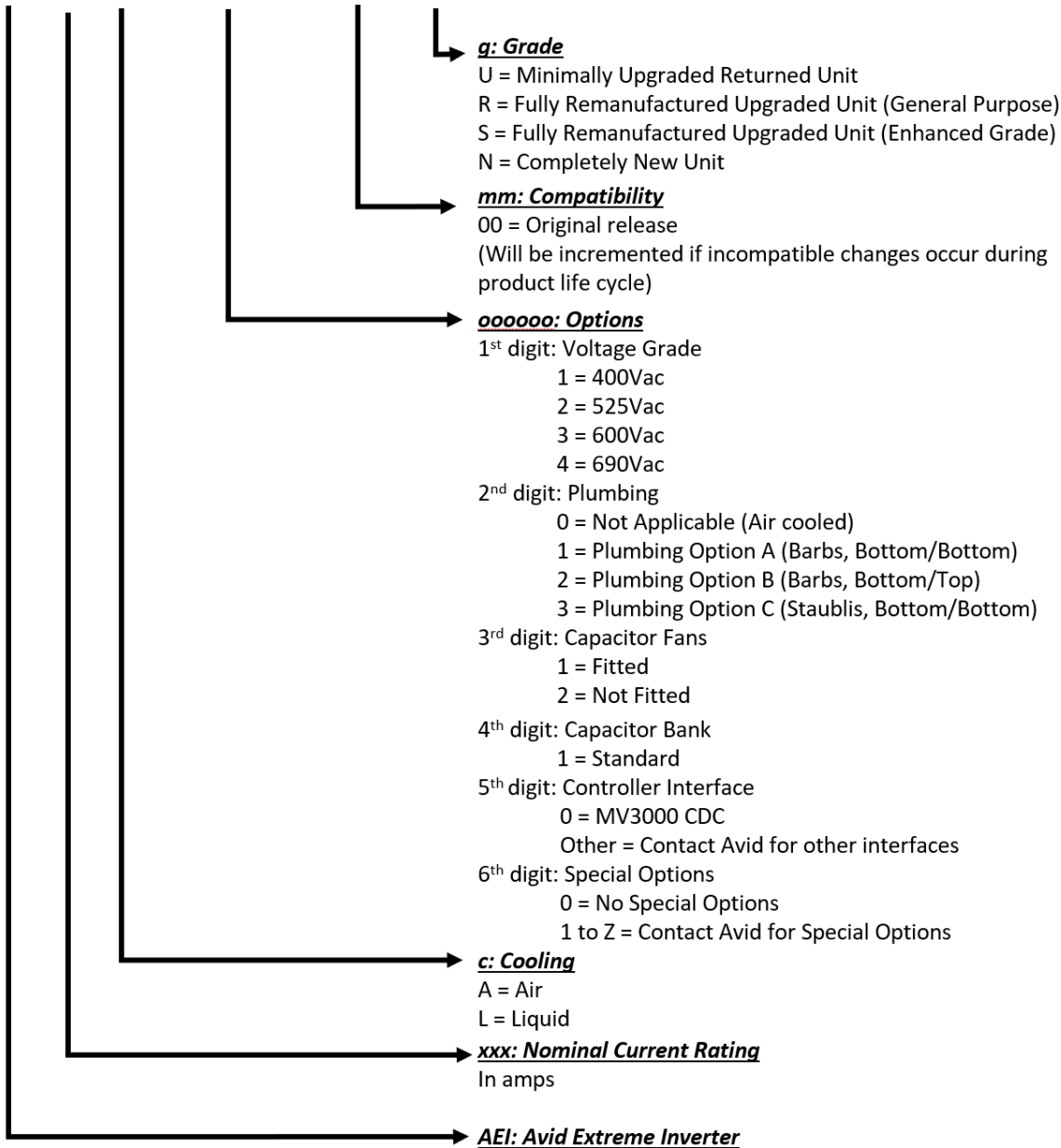

- Unless otherwise stated, this data sheet is applicable to all CDC interfaced Avid Extreme Inverter models beginning AEI900L, AEI1000L, AEI1250L and AEI1400L.
- Note that not all options that can be defined by this scheme are actual products – contact Avid Controls for specific product availability.

3.2 Electrical – Power Section

| Specification | AEI900L | AEI1000L | AEI1250L | AEI1400L | Notes & Applicable Conditions |
|---|----------|----------|-----------------------|--------------|---|
| Continuous Current, 690V Renewable Energy Applications* | 900A | 1000A | Contact Avid Controls | | 60s Overload = 110% once per 10 minutes DC Link Voltage = 1100V Coolant Temp. = 60°C PWM Frequency = 1.8kHz (Generator) = 2.5kHz (Network) Generator Power Factor = -0.89 Network Power Factor = 1.00 Generator & Mains Freq. > 20Hz |
| Continuous Current, 600V Pump Applications* | 900A | 1000A | 1250A | 1400A | 60s Overload = 110% once per 10 minutes DC Link Voltage = 850V Coolant Temp. = 60°C 50°C for AEI1400L PWM Frequency = 2.5kHz Motor Power Factor = 0.85 Motor Frequency > 20Hz |
| Continuous Current, 690V Pump Applications* | 900A | 1000A | 1250A | Contact Avid | 60s Overload = 110% once per 10 minutes DC Link Voltage = 975V Coolant Temp. = 60°C 50°C for AEI1250L PWM Frequency = 2.5kHz Motor Power Factor = 0.85 Motor Frequency > 20Hz |
| Continuous Current, 600V Hoist Applications* | 660A | 733A | 916A | 1026A | 60s Overload = 150% once per 10 minutes DC Link Voltage = 820V Coolant Temp. = 60°C PWM Frequency = 2.5kHz Motor Power Factor = 0.85 Motor Frequency > 1Hz |
| Continuous DC Link Operating Voltage | 1188 V | | | | |
| Short Term (7.5s) DC Link Operating Voltage | 1262 V | | | | |
| Non-Operating DC Link Withstand Voltage | 1350 V | | | | |
| DC Link Capacitance | 11600 µF | 16800 µF | 16433 µF | 23800 µF | +20/-10 % |
| Maximum PWM Frequency | 2.5 kHz | | | | In some circumstances, higher frequencies may be used with de-rating – contact Avid Controls if this is required. |

*For other applications contact AVID Controls Inc.

3.3 Electrical – Control & Interface Section

| Specification | <i>AEI900L / AEI1000L</i> | <i>AEI1250L / AEI1400L</i> | Notes |
|-----------------------------------|--|--|--|
| Control Power Source | Avid Auxiliary Power Unit (APU) Model Numbers: AEI-APU-B AEI-APU-C AEI-APU-D AEI-APU-E AEI-APU-F | Avid Auxiliary Power Unit (APU) Model Number: AEI-APU-C AEI-APU-D AEI-APU-E | Customers wishing to provide their own auxiliary power <u>MUST</u> contact Avid Controls for further information. Models AEI-APU-B & -C are legacy items no longer produced by Avid Controls. See Avid Data Sheet DTS-MID0124 for complete data on the -D,-E & -F models. |
| Analog Outputs | 4 Channels +/-10V | | Optional indication for phase currents, temperatures etc. DIP switch function selection See section 6.3 for more details |
| Fault Indication | <ul style="list-style-type: none"> • Fault Codes indicated by controller for all compatible faults • Two-digit LED display for additional diagnostic codes • Two 24V Solid-State relay outputs for indication of fault status | | See section 7.5 for definition of fault codes. |
| Operational Indication | Two-digit LED display for display of DC link voltage, currents and temperatures | | See section 7.4 for details. |
| Remote Monitoring | Two wire RS485 (non-isolated on earlier units, fully isolated on later units) MODBUS RTU Protocol | | See section 8 for details. |
| DC Link Voltage Feedback Accuracy | +/- 4V @ 1000V DC | | Measured internally within inverter unit |

3.4 Cooling

| Specification | <i>Value</i> |
|-----------------------------------|---|
| Coolant Type | Water / Ethylene Glycol Maximum 50% Ethylene Glycol With suitable corrosion inhibitors |
| Minimum Coolant Flow | 25 liters/min (6.6 US-GPM) |
| Maximum Coolant Inlet Pressure | 300kPa (45psi) |
| Maximum Coolant Inlet Temperature | 60°C (50°C for maximum current rating of AEI1250L & AEI1400L) |
| Minimum Coolant Inlet Temperature | 0°C |
| Coolant Strainer | Coolant must be strained to remove particles Maximum recommended strainer mesh is 0.7mm (0.028") Inspect and clean strainer every six months |
| Coolant Lifetime | Check coolant constituent concentration every six months Remove coolant, flush system with de-ionized water and refill with new coolant every 24 months. |
| Coolant Connection Options | <ul style="list-style-type: none"> • 2x hose-barb at bottom of unit (Option A) • 1x hose-barb top, 1x hose-barb bottom (Option B) • 2x Quick-Disconnect at bottom of unit (Option C) |

| Specification | <i>Value</i> | | | | |
|---|--------------|---------------------|-----------------|--------------|----------------------------|
| Typical heat loads to coolant (allow 33% more than quoted values when designing cooling system) | DC Link V | PWM Freq. kHz | Power Factor | Current A | Typical Heat Load kW |
| | 1100 | 2.5 | 1.0 | 800 | 8.7 |
| | | | | 900 | 10.0 |
| | | | | 1000 | 11.5 |
| | | | | 1250 | 14.8 |
| | | 1.8 | -0.89 | 800 | 7.0 |
| | | | | 900 | 8.0 |
| | | | | 1000 | 9.1 |
| | | | | 1250 | 11.8 |
| | 976 | 1.25 | 0.90 | 900 | 6.3 |
| | | | | 1000 | 7.2 |
| | | | | 1250 | 9.4 |
| | 850 | 1.25 | 0.90 | 900 | 5.9 |
| | | | | 1000 | 6.7 |
| | | | | 1400 | 10.3 |
| | | 2.5 | 0.90 | 900 | 8.1 |
| | | | | 1000 | 9.1 |
| 1400 | | | | 14.0 | |

3.5 Environmental

| Specification | Value |
|---|---|
| Ambient Temperature (Internal cabinet temperature) | 0 to 50°C |
| Cabinet air | Pollution Degree 2 as per IEC60664-1, UL 840 & CSA C22.2 No. 0.2-93 i.e. clean, free from dust, condensation and conductive or corrosive gases. Maximum chemicals 15ppm H ₂ S, 25ppm NO ₂ , 25ppm SO ₂ |
| Humidity | 5% to 95% RH Unit must not be operated in the presence of condensation. |
| | |

3.6 Mechanical

| Specification | Value |
|---------------|---|
| Dimensions | 248mm W x 1232mm H x 546mm D (9.75" W x 48.5" H x 21.5" D) |
| Enclosure | IP00 (IEC 60529:1989; BS EN 60529:1992) NEMA 1 Must always be installed within suitable enclosure with restricted access |
| Mass | 105kg (231 lb.) for AEI900L/AEI1000L 125 kg (276 lb.) for AEI1250L/AEI1400L |

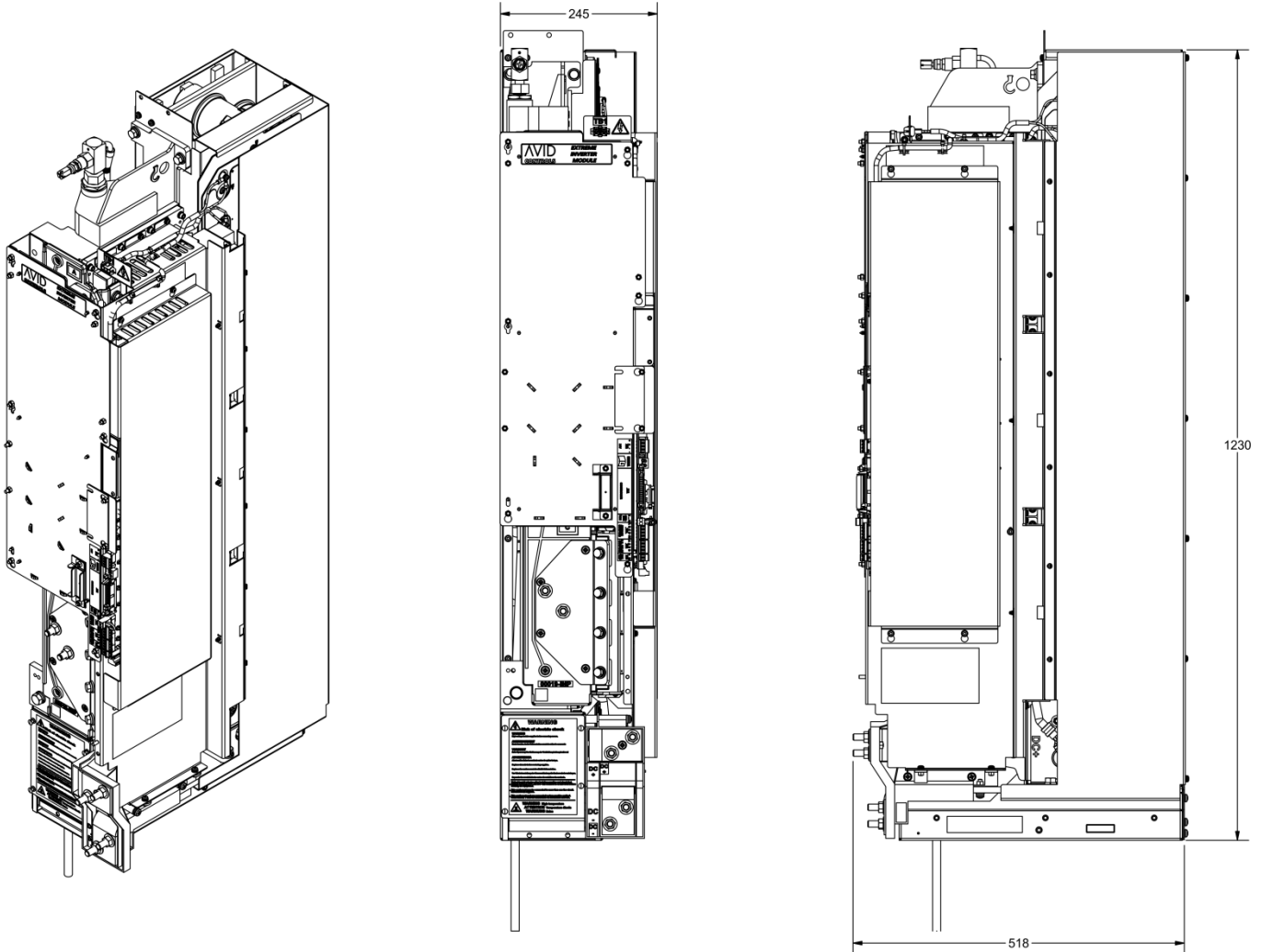

4. High Voltage / Power Connections

| Connection | Value for AEI900L | Value for AEI1000L / AEI1250L / AEI1400L |
|--------------------|---|---|
| AC Power Terminals | 2 x M10 studs per phase Maximum cable size per stud is 120mm ² | 3 x M10 studs per phase Maximum cable size per stud is 120mm ² |
| DC Power Terminals | 2 x M10 studs each for DC+ and DC- Maximum cable size per stud is 120mm ² | 3 x M10 studs each for DC+ and DC- Maximum cable size per stud is 120mm ² |
| Ground Connection | 1 x M10 bolt | |

- The recommended torque for M10 power connections is 35 Nm.

5. Low Voltage / Control Connections

5.1 Overview

- All control connections are made to terminals and plugs on the **Controller Interface Board** (hereinafter referred to as the **C.I.B.**) as shown in the following image (left hand side is towards the top of the unit when installed):

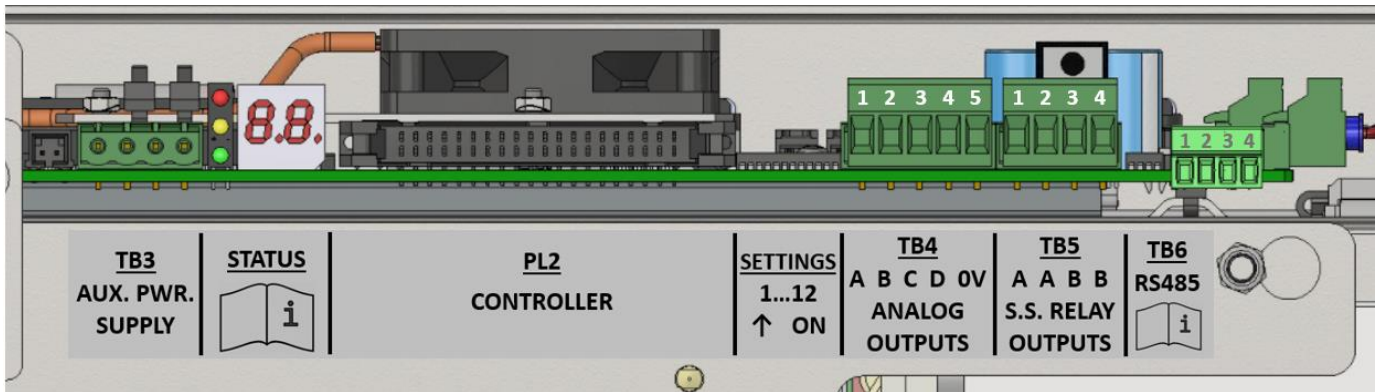

- On early units, TB6 is a 2-pin connector and there is no yellow status LED. Improvements in the function of the RS485 communications have been implemented in later units – these are detailed in the appropriate sections.
- The terminal blocks may not be physically numbered – pin one is always towards the top of the unit when installed.
- The pin numbers for TB3 are not shown since the cable and header are pre-made as part of the Auxiliary Power Unit assembly.

5.2 Plugs for TB3, TB4 & TB5

- The pluggable part of TB3 is part of the Auxiliary Power Unit assembly, hence no plug is provided or needed in the AEI module for this connector.
- The functions of TB4 (analog outputs) and TB5 (solid-state relays) are rarely used in AEI applications, and in certain Delta module replacement applications can cause a fitment issue.
- To avoid any fitment issues, and to avoid the wasteful fitting of these plugs, AEI modules ship from Avid without these plugs.
- If you wish to use these features, the following table lists some of the widely available options for these plugs:

| Plug | Description | Approved Parts |
|------|-------------------------------------|---|
| TB4 | Five pin 0.2” Horizontal Entry Plug | TE Connectivity: Part Number 796634-5 Molex: Part Number 395305005 Phoenix Contact: Part Number 1757048 Würth: Part Number 691351500005 Amphenol: Part Number TJ0551530000G |
| TB5 | Four pin 0.2” Horizontal Entry Plug | TE Connectivity: Part Number 796634-4 Molex: Part Number 395305004 Würth: Part Number 691351500004 Amphenol: Part Number TJ0451530000G |

- These plugs may also be obtained by contacting Avid Controls Inc.

5.3 Shipping/Handling Protector for 40-Way Ribbon, PL2

- The 40-way ribbon connector, PL2, is shipped from Avid with a protector to prevent damage during handling of the AEI module.
- This should be removed immediately prior to carefully inserting the ribbon cable from the CDC module:

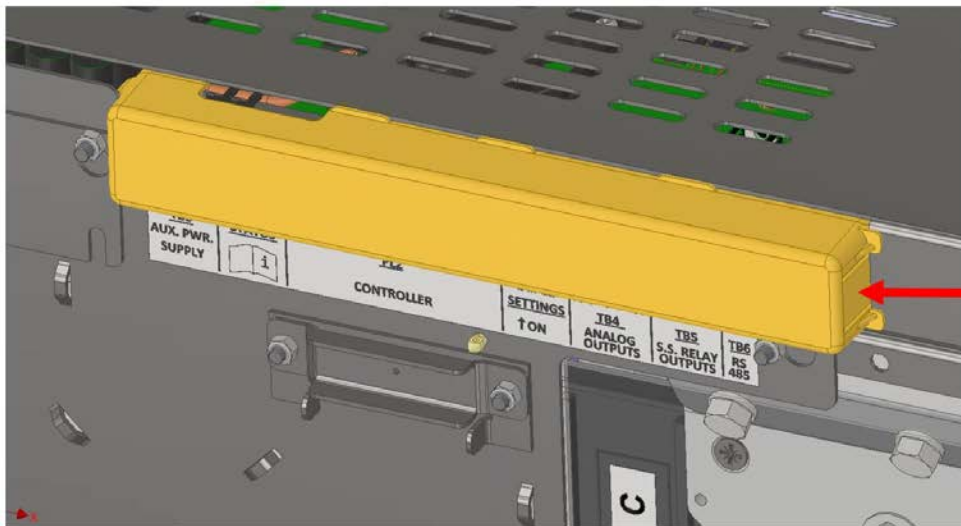

PRESS HERE TO
DISENGAGE PROTECTOR
FROM COVER

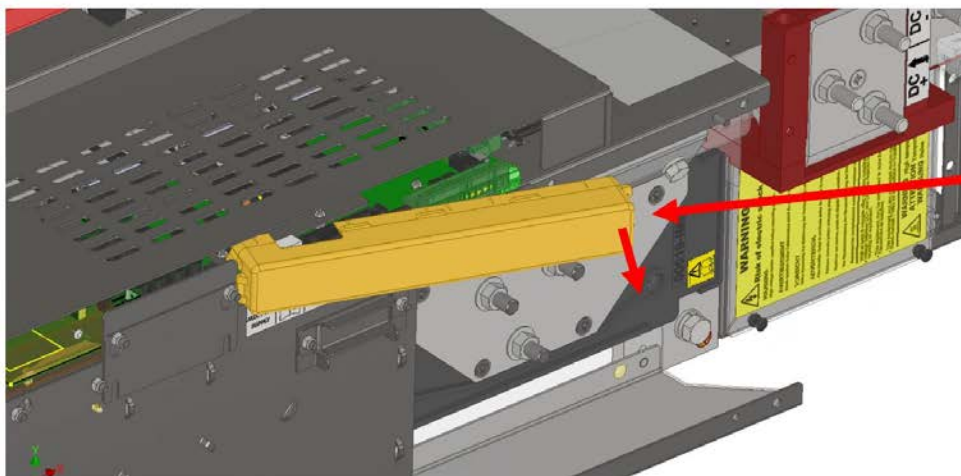

ROTATE PROTECTOR
AWAY FROM COVER AND
REMOVE

- This protector should be kept safe and re-fitted if it is ever necessary to remove the AEI unit.

5.4 TB3 – Auxiliary Power Supply

- Auxiliary power is generally provided to the AEI unit from an Avid Auxiliary Power Unit.
- For reference, the following gives more details of TB3:

| Terminals | Function | Specifications and Notes |
|-----------|--------------------------|---|
| 1 | CONTROL POWER SUPPLY [+] | <ul style="list-style-type: none"> • Provides power for controller interface and IGBT drivers • 24V DC, +/-5%, 5A maximum load • Voltage transients during power on/off must be monotonic • Supply must meet application power loss ride-through requirements. • [-] terminals are connected to system 0V [GROUND] on the C.I.B. |
| 3 | CONTROL POWER SUPPLY [-] | |
| 2 | FAN POWER SUPPLY [+] | <ul style="list-style-type: none"> • Provides power for AEI internal cooling fans (when fitted) • 24V DC, +/-10%, 10A maximum load • Negative supply must be externally connected to system 0V [GROUND] |
| 4 | FAN POWER SUPPLY [-] | |
| | | |

- Customers wishing to provide their own auxiliary power should contact Avid Controls for further information and approval of proposed power supply equipment and connections. Customers **MUST NOT** use an unapproved auxiliary power scheme, doing so will void the product warranty.

5.5 TB4 – Analog Outputs

| Terminals | Function | Specifications and Notes |
|------------|--------------------------|--|
| 1, 2, 3, 4 | ANALOG OUTPUT A, B, C, D | <ul style="list-style-type: none"> • Analog outputs for user diagnostic monitoring • See section 6.3 for details on selecting specific signals to be output via analog outputs. • Range is +/-10V • Maximum load current is 5mA • Output source impedance is 100Ω • Maximum error at all outputs is +/- 1% of full range with zero load • Pin 5 (0V – GND) is connected to system 0V [GROUND] on the C.I.B. |
| 5 | 0V (GND) | |
| | | |

5.6 TB5 – Solid State Relays

| Terminals | Function | Specifications and Notes |
|-----------|------------|---|
| 1, 2 | SS RELAY A | <ul style="list-style-type: none"> • Inverter module fault indication • Relay energized indicates no fault condition • Relay de-energized indicates a fault condition |
| 3, 4 | SS RELAY B | <ul style="list-style-type: none"> • Internal cooling fan fail indication • Relay energized indicates internal cooling fans are operating normally • Relay de-energized indicates internal cooling fans are operating below minimum speed • Under high load conditions, the unit will trip with a fan fail fault. See section 7.6 for details |
| | | <ul style="list-style-type: none"> • Maximum operating voltage is 60Vdc / 40Vac(rms) • Maximum load current is 0.4A • Typical ON resistance is 0.5 Ω • NOT overload (short-circuit) or overvoltage protected • For reference, on-board device is <i>Panasonic AVQ202A</i> or <i>AVQ252GA</i> solid-state relay. |

5.7 TB6 – RS485

- The AEI inverter has a single 2-Wire RS485 (5V) port at TB6.
- See section 8, MODBUS Communications for a complete functional description of the operation of the RS485 port.

Early Units

- This port is non-isolated and is referenced to system 0V (GROUND).
- The pin out of this is:

| Terminal | Function | Notes |
|----------|----------|--|
| 1 | DATA+ | <ul style="list-style-type: none"> • RS485 (5V) 2-Wire data |
| 2 | DATA- | |

- The DATA+/- signals are referenced to the internal 0V of the AEI, which is connected to the chassis and thus to the cabinet steelwork. The remote node of the RS485 must be similarly referenced with a maximum common mode voltage of +/-20V. For reference, the transceiver device used is a *Texas Instruments SN65HVD23*.
- If bus termination is required, an external 120 Ω resistor (minimum suggested rating of 0.5W) can be fitted across DATA+ & DATA-.

Later Units

- This port is fully isolated and has its own reference zero volts. ***Note that the isolation is provided for signal integrity and is not specified as a safety isolation barrier. All conductors on the RS485 connector must be maintained at safe low voltages.*** For signal integrity purposes, the isolation is rated at a minimum of 1500VDC.
- The pin out of this is:

| Terminal | Function | Notes |
|----------|----------|--|
| 1 | TERM+ | <ul style="list-style-type: none"> • One end of a 120 Ω resistor • The other end is internally connected to the DATA- signal • To terminate the RS485 bus at an AEI unit, connect this terminal to the DATA+ terminal (connect together pins 1 & 2) |
| 2 | DATA+ | <ul style="list-style-type: none"> • RS485 (5V) 2-Wire data |
| 3 | DATA- | |
| 4 | RS485 0V | <ul style="list-style-type: none"> • This is the reference ground of the RS485 signals • It is not connected to system 0V (GROUND) • All RS485 0V connections (including the master device) should be connected for correct operation of the RS485 network |

5.8 PL2 – Controller Connection

- Standard 40-way ribbon cable header for connection to a CDC.

6. User Selectable Options

6.1 Overview

- There are a number of options for the inverter unit that must be configured.
- These are configured using a set of 12 DIP switches on the C.I.B.
- These switches are numbered from 1 to 12, the ON position is towards the PCB itself, and the OFF position is towards the edge of the board.
- On later models, an additional set of 4 DIP switches is added adjacent to TB6 to configure the RS485 communications port.
- The DIP switches are very small, so a fine point instrument is needed to set them correctly.
- The default options are identified in the following descriptions.

6.2 Over-volts Trip Mode (SW1 to SW4)

- The overvoltage thresholds and delays are configured by **SW1** to **SW4**.
- The following table defines the operation of these switches:

| SWITCH SETTINGS | | | | DC Link Voltage Trip Instant | DC Link Voltage Trip Delayed | Delay Time | Notes |
|-----------------|------|------|------|------------------------------|------------------------------|------------|--|
| SW 1 | SW 2 | SW 3 | SW 4 | | | | |
| OFF | OFF | OFF | OFF | 1188 Vdc | None | N/A | Legacy behavior for non-renewable energy systems |
| OFF | OFF | OFF | ON | 1262 Vdc | 1188 Vdc | 0.5s | Units configured in one of these modes are used in position 1 of the system. <u>Default is 1s delay.</u> |
| OFF | OFF | ON | OFF | | | 1.0s | |
| OFF | OFF | ON | ON | | | 1.5s | |
| OFF | ON | OFF | OFF | | | 2.0s | |
| OFF | ON | OFF | ON | | | 2.5s | |
| OFF | ON | ON | OFF | | | 3.0s | |
| OFF | ON | ON | ON | | | 3.5s | |
| ON | OFF | OFF | OFF | | | 4.0s | |
| ON | OFF | OFF | ON | | | 4.5s | |
| ON | OFF | ON | OFF | | | 5.0s | |
| ON | OFF | ON | ON | | | 5.5s | |
| ON | ON | OFF | OFF | | | 6.0s | |
| ON | ON | OFF | ON | | | 6.5s | |
| ON | ON | ON | OFF | | | 7.5s | |
| ON | ON | ON | ON | 1290 Vdc | None | N/A | This mode may be used in positions 2 to 6 of a parallel inverter system. |

6.3 Analog Output Mode (SW5 and SW6)

- The unit provides four analog outputs for system monitoring / debugging.
- See section 5.5 for electrical specifications.
- Scaling of different signal types is as follows:

| Signal Type | Scaling |
|-----------------|---|
| Current | <ul style="list-style-type: none"> • +/- 10 V output is equivalent to +/- 2500A • Positive values are defined as positive current OUT of the AC terminals of the unit. • When the output mode is rectified phase currents, only positive values will be output. • The formula for rectified mode is: Output = MAXIMUM (Ia , Ib , Ic). |
| DC Link Voltage | <ul style="list-style-type: none"> • 0 to +10V is equivalent to 0 to 1500 Vdc |
| Temperature | <ul style="list-style-type: none"> • 0 to +10V is equivalent to 0 to 150°C • Note that due to the nature of the internal temperature sensor, any temperature below 30°C will be indicated as 30°C. |

- The signals that are output are controlled by DIP switches **SW6 & SW7**:

| Switch Positions | | Mode | Analog Channel Outputs | | | |
|------------------|-----|----------|---------------------------------------|---------------------------------|---------------------------------|-----------------|
| SW5 | SW6 | | A | B | C | D |
| OFF | OFF | MIXED | Full wave rectified AC currents | Maximum IGBT module temperature | Minimum IGBT module temperature | DC Link Voltage |
| ON | OFF | CURRENTS | A phase AC current | B phase AC current | C phase AC current | |
| OFF | ON | TEMPS. | A phase IGBT module temperature | B phase IGBT module temperature | C phase IGBT module temperature | |
| ON | ON | UNUSED | Undefined value between -10V and +10V | | | |

- **The default mode is MIXED.**

6.4 Compatibility Rating Mode (SW7)

- Certain models of Avid Extreme Inverter may be configured to report a lower rating to the controller than that of which they are actually capable.
- This feature is provided to support compatibility with legacy systems and to increase flexibility in different applications.
- Not all Avid Extreme Inverter units support a compatibility rating.
- Compatibility Rating Mode is enabled by setting DIP switch **SW7** to the ON position (its ***default is OFF***).
- The following table shows those modules that support this mode:

| MODEL | Compatibility Rating (Reported to Controller) (DIP Switch SW7 = ON) |
|-----------------------------------|--|
| AEI900L | 110% Overload Duty: 800A 150% Overload Duty: 587A |
| AEI1000L / AEI1250L / AEI1400L | No compatibility rating is supported. SW7 has no effect. |

6.5 MODBUS Address Setup Switches

- These three switches set the MODBUS Slave Address of the AEI.
- On older units these are SW8 to SW10 on the main DIP switch bank. These have no function on newer units.
- On newer units these are SW1 to SW3 on the small DIP switch bank adjacent to TB6. Like the main DIP switch bank, these are numbered SW1 to SW4 from top to bottom when the unit is installed vertically in a cabinet.
- The functions are as follows:

| SWITCH SETTINGS | | | MODBUS SLAVE ADDRESS | Notes |
|---------------------------------|---------------------------------|----------------------------------|----------------------|---|
| SW8 (MAIN) or SW1 (RS485) | SW9 (MAIN) or SW2 (RS485) | SW10 (MAIN) or SW3 (RS485) | | |
| OFF | OFF | OFF | 1 | As can be seen, the MODBUS slave address is <i>1 + SW[]</i> <i><u>The default is OFF OFF</u></i> <i><u>OFF</u></i> : Slave Address = 1 |
| OFF | OFF | ON | 2 | |
| OFF | ON | OFF | 3 | |
| OFF | ON | ON | 4 | |
| ON | OFF | OFF | 5 | |
| ON | OFF | ON | 6 | |
| ON | ON | OFF | 7 | |
| ON | ON | ON | 8 | |

- See section 8 for details of the MODBUS communication function.

6.6 MODBUS Sample Mode (Newer Units Only)

| SW4 (RS485) | Sample Mode | Notes |
|-----------------------------|--------------------------|-----------------------------|
| <i>OFF (Default)</i> | Standard Sample Mode | See section 6.6 for details |
| ON | Simultaneous Sample Mode | |

6.7 Unused Switches













- SW11 and SW12 on older units, or SW8 through SW12 newer units, currently have no assigned functions.
- ***They should be left in the OFF position to ensure compatibility with any future upgrades.***

7. LED's and Fault Indication

- The unit has two discrete LED's (red and green) and a two-digit LED display.
- The discrete LED's indicate the operational state of the unit and the numeric display may either indicate various feedback signals or all active faults.

7.1 Discrete RED & GREEN LED's

 - OFF  - ON  - FLASHING

| RED LED | GREEN LED | Meaning |
|---|---|---|
|  |  | Auxiliary supply is not present |
|  |  | Internal error present on C.I.B. or auxiliary supply is out of tolerance |
|  |  | Unit healthy (not tripped) and disabled (IGBT's not switching) |
|  |  | Unit healthy (not tripped) and enabled (IGBT's switching) |
|  |  | Unit faulted. Fault codes will be displayed on 2-digit display, appropriate fault codes sent to controller (as supported – see section 7.5) |
|  |  | Controller is attempting a reset cycle |

7.2 Discrete YELLOW LED (Newer Units Only)

- On newer units a YELLOW LED has been added.
- When illuminated, this indicates that a FAN FAIL condition exists and that, depending upon load current, a unit trip may occur in the future.
- See section 7.6 for more details on fan monitoring.

7.3 Program Version Display

- When the auxiliary power is applied, the 2-digit LED displays the C.I.B. program version for three seconds.
- This version is also displayed on a small label on the front of the unit. This information will be required by Avid when providing technical assistance.

7.4 LED Feedback Indication

- After power up, when the unit is not faulted, the 2-digit LED display cycles through indications of several operational feedbacks.
- Each feedback is displayed for 1s, before the display cycles to the next feedback. A "--" pattern is used to indicate the start of the cycle.
- The cycle is:

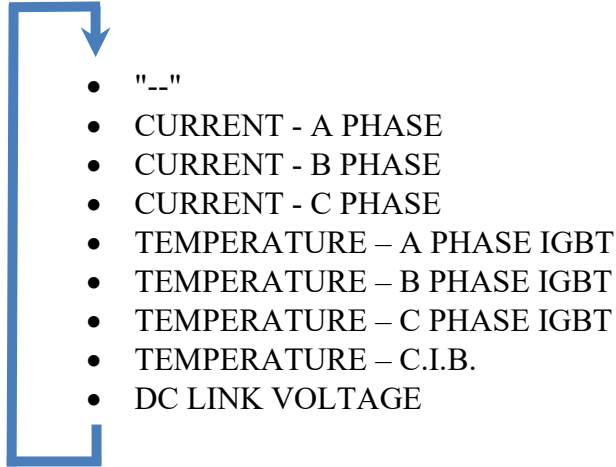

- In a similar manner to the analog outputs, most values are displayed as the percentage of a defined value. The exception is the C.I.B. temperature which is displayed in °C.

| Signal Type | Explanation & Scaling |
|--------------------|--|
| Current | <ul style="list-style-type: none"> • 100% output is equivalent to 2500A • The formula for the indication is: <ul style="list-style-type: none"> ○ % CURRENT = 100% X AVERAGE_{1s} (Phase Current) / 2500A • Or, in words, the formula is <i>the absolute current averaged over 1s, expressed as a percentage of 2500A</i> • This will produce fluctuating display values at lower power frequencies as the 1s average period beats with the current waveform • For reference, the relationship between AVERAGE OF MEAN and RMS values for a sinusoid is AVERAGE = 0.90 X RMS |
| DC Link Voltage | <ul style="list-style-type: none"> • Average over 1s expressed as percentage of 1500 Vdc |
| IGBT Temperature | <ul style="list-style-type: none"> • Expressed as percentage of 150°C (0°C = 0%, 150°C = 100%) • Note that due to the nature of the internal temperature sensor, any temperature below 30°C will be indicated as 20%. |
| C.I.B. Temperature | <ul style="list-style-type: none"> • This is displayed in °C • Note due to absence of negative sign any value below 0°C will be displayed as '00' |

7.5 Fault Codes

- When the unit has a fault, the 2-digit LED display cycles through a list of all active faults.
- Each fault that the unit recognizes is encoded into a compatible fault code for indication by the controller.
- The Avid unit can identify many more and different faults than the controller can recognize, so some rationalization has been necessary.
- The following table describes each fault code on the unit, together with the fault code that is transmitted to the controller for each of the faults recognized by the C.I.B.:

| Fault Code on LED Display | Meaning | Trip Code Transmitted to Controller* ¹ |
|---------------------------|---|---|
| 1 | A Phase IGBT Self-Protect Fault | 31 |
| 2 | B Phase IGBT Self-Protect Fault | 33 |
| 3 | C Phase IGBT Self-Protect Fault | 35 |
| 4 | A Phase Heatsink Over Temperature Fault | 32 |
| 5 | B Phase Heatsink Over Temperature Fault | 34 |
| 6 | C Phase Heatsink Over Temperature Fault | 36 |
| 7 | A Phase Silicon Over Temperature Fault | 32 |
| 8 | B Phase Silicon Over Temperature Fault | 34 |
| 9 | C Phase Silicon Over Temperature Fault | 36 |
| 10 | Over Voltage (DC Link) | 38 |
| 11 | External Trip Fault | 37 |
| 12 | Internal Fan 1 Failure (on units where this fan is fitted) | 243 |
| 13 | Internal Fan 2 Failure (on units where this fan is fitted) | 243 |
| 14 | Internal Fan 3 Failure (on units where this fan is fitted) | 243 |
| 15 | External Fan Failure (on units where this fan is fitted) | 243 |
| 16 | Incoming Power Supply Fault | 240 |
| 17 | Internal Power Supply Fault (+15V) ^{*2} | 241 |
| 18 | Internal Power Supply Fault (-15V) ^{*2} | 242 |
| 19 | Internal Power Supply Fault (IGBT) ^{*2} | 240 |
| 20 | Internal Power Supply Fault (+3V5) ^{*2} | 240 |
| 21 | Internal PWM Deadtime Fault (A Phase) ^{*2} | 247 |
| 22 | Internal PWM Deadtime Fault (B Phase) ^{*2} | 248 |
| 23 | Internal PWM Deadtime Fault (C Phase) ^{*2} | 249 |

| Fault Code on LED Display | Meaning | Trip Code Transmitted to Controller ^{*1} |
|---------------------------|--|---|
| 24 | Internal PWM Frequency Fault (A Phase) ^{*2} | 244 |
| 25 | Internal PWM Frequency Fault (B Phase) ^{*2} | 245 |
| 26 | Internal PWM Frequency Fault (C Phase) ^{*2} | 246 |
| 27 | A Phase Positive Instantaneous Overcurrent | 31 |
| 28 | A Phase Negative Instantaneous Overcurrent | 31 |
| 29 | B Phase Positive Instantaneous Overcurrent | 33 |
| 30 | B Phase Negative Instantaneous Overcurrent | 33 |
| 31 | C Phase Positive Instantaneous Overcurrent | 35 |
| 32 | C Phase Negative Instantaneous Overcurrent | 35 |
| 33 | DC Link Feedback Fault ^{*2} | 212 |
| 34 | Internal Fault ^{*2} | 212 |
| 35 | Interface Board Over Temperature (65°C) | 212 |
| 36 | Internal Data Error ^{*3} | 212 |

***1:** The fault code for a unit connected to position 1 of the controller system is given. For units in other positions the equivalent fault code will be displayed by the controller.

***2:** These faults indicate a fault within the inverter unit. They do not occur in normal operation and user fault-finding is generally not possible. In the unlikely event that these faults are experienced, contact Avid Controls for support.

***3:** This fault can happen if the connected CDC (controller) makes an incomplete attempt to reprogram the internal data. Reprogramming is possible with access to the controller's maintenance features.

7.6 Internal Cooling Fan Fault

- AEI units with internal cooling fans continually monitor the fans' speed and take action if they drop below minimum speed.
- Certain AEI900L and AEI1000L models do not have internal cooling fans. In these cases, the user **MUST** implement external capacitor cooling fans for the unit. These external fans are **NOT** monitored by the unit and their failure may result in failure of the unit. If you are using AEI900L or AEI1000L units without internal fans, it is highly recommended that you contact Avid Controls for additional technical support.
- All units immediately indicate fan failure via SS RELAY B, see section 5.6 for details.
- After a load dependent delay, the unit will fault, indicating the appropriate fault code from section 7.5
- The following figure shows the fault delay time as a function of the load current:

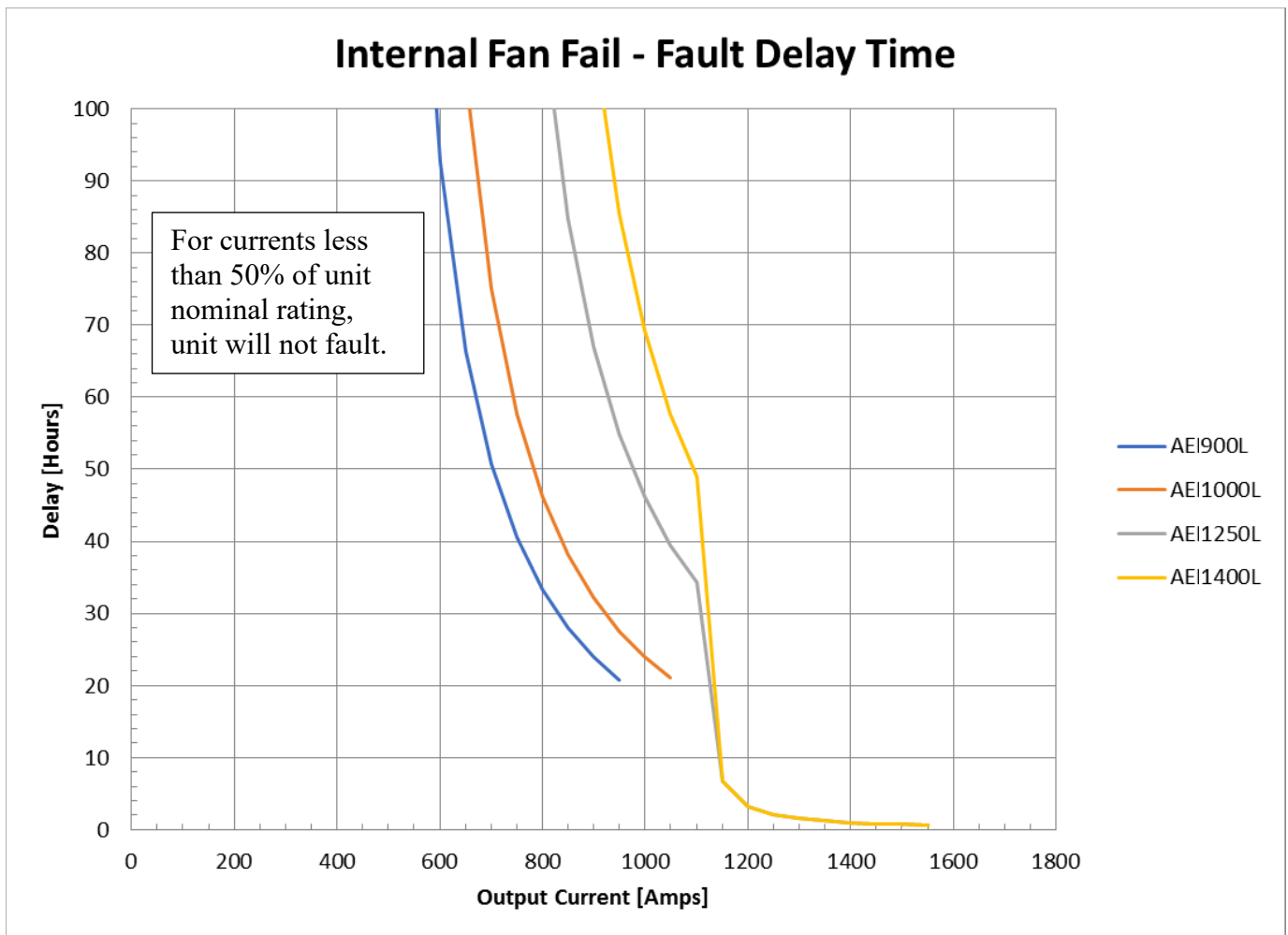

8. MODBUS¹ Communications

8.1 Introduction

- The AEI implements a small subset of the MODBUS RTU SLAVE PROTOCOL via the 2-wire RS485 port on TB6.
- The port has the following physical and data specifications:
 - Electrical Levels: TIA/EIA RS485, 5V
 - Isolation: **Older Units:** None. Signals are referenced to system 0V (chassis). Maximum common mode voltage is +/-20V.
Newer Units: Fully isolated for signal integrity. Maximum isolation voltage (not for safety) is 1500V.
 - Baud Rate: 115200 bits per second
 - Parity: None
 - Data Bits: 8
 - Stop Bits: 1
 - Termination: **Older Units:** None. If needed an external termination resistor must be added at TB6.
Newer Units: An internal 120Ω termination resistor may be connected across the RS485 bus by linking TB6/1 to TB6/2

8.2 MODBUS_TIMER

- The AEI maintains a 1ms timer, **MODBUS_TIMER**, that counts continuously and overflows from 65535 to 0 every 65.536 seconds.
- The value of **MODBUS_TIMER** is one of the diagnostic fields that is provided via the MODBUS link.
- The following MODBUS function is used to synchronize **MODBUS_TIMER** between all AEI's connected to the MODBUS network:
 - MODBUS Address: 00 (Global Address)
 - MODBUS Function: 06 – Write Single Register
 - Register Address: 0
 - Write Data: Data is loaded immediately (< 1ms) into **MODBUS_TIMER** by all AEI's that validate the received message

8.3 Diagnostic Data

- The AEI will transmit 32 words of diagnostic data in response to a MODBUS query.
- The following MODBUS function is used to read diagnostic data from the AEI:
 - MODBUS Slave Address: 01 to 08, switch selectable
 - MODBUS Function: 03 – Read Holding Registers
 - Base Register Address: 0
 - Read Length: 32

¹ MODBUS is a registered trademark of Schneider Automation Inc.

- The following table defines the diagnostic data that is transmitted:

| REG. | NAME | TYPE | NOTES | |
|------|-------------------|-----------|---|---|
| 0 | SER_NUM | UNSIGNED | This is the AEI serial number. Does not change. | |
| 1 | TIMER | UNSIGNED | Free running <i>1ms</i> timer that can be written using MODBUS Global Address – see section 8.2. Sampled when read. | |
| 2 | FAULT_1_16 | BIT FIELD | BIT 0 is FAULT_1 BIT 15 is FAULT_16 Each bit of these <i>bit fields</i> indicates if the fault designated by the equivalent code is active. See section 7.5 for list of fault codes. Sampled when read. | |
| 3 | FAULT_17_32 | BIT FIELD | | BIT 0 is FAULT_17 BIT 15 is FAULT_32 |
| 4 | FAULT_33_48 | BIT FIELD | | BIT 0 is FAULT_33 BIT 15 is FAULT_48 |
| 5 | FAN_1_SPEED | UNSIGNED | The speed, in <i>RPM</i> , of the internal cooling fans. Sampled when read. Note that the AEI detects a fault if these speeds fall below safe values (the exact value varies based upon a number of factors). See section 7.6 for details. These are provided to allow the user to compare speeds <i>between</i> AEI's and with <i>historical</i> values, giving the possibility of identifying a unit with a fan problem prior to failure. | |
| 6 | FAN_2_SPEED | UNSIGNED | | |
| 7 | FAN_3_SPEED | UNSIGNED | | |
| 8 | MAX_POS_CURRENT_A | SIGNED | The maximum positive current, in <i>AMPS</i> , of each output phase of the AEI, since the diagnostic data was last transmitted. This will be a positive value. | |
| 9 | MAX_POS_CURRENT_B | SIGNED | | |
| 10 | MAX_POS_CURRENT_C | SIGNED | | |
| 11 | MAX_NEG_CURRENT_A | SIGNED | The maximum negative current, in <i>AMPS</i> , of each output phase of the AEI, since the diagnostic data was last transmitted. This will be a negative value. | |
| 12 | MAX_NEG_CURRENT_B | SIGNED | | |
| 13 | MAX_NEG_CURRENT_C | SIGNED | | |
| 14 | AVG_CURRENT_A | SIGNED | The average absolute current, in <i>AMPS</i> , of each output phase of the AEI, since the diagnostic data was last transmitted. Note that the current is first rectified before the average is calculated, so that positive or negative output currents are not differentiated. Note that (due to storage limits) the evaluation of average is suspended after 32767 PWM periods of evaluation (13s at 2.5kHz PWM). So to utilize this data, it must be accessed at least this often. | |
| 15 | AVG_CURRENT_B | SIGNED | | |
| 16 | AVG_CURRENT_C | SIGNED | | |
| 17 | IGBT_TEMP_A | SIGNED | The temperature, in <i>0.1°C</i> units, of the IGBT temperature feedback devices. Sampled when read. | |
| 18 | IGBT_TEMP_B | SIGNED | | |
| 19 | IGBT_TEMP_C | SIGNED | | |

| REG. | NAME | TYPE | NOTES | | | | |
|------|-----------------|-----------|---|----------------|-----------------|--|--|
| 20 | MAX_IGBT_TEMP_A | SIGNED | The maximum temperature, in 0.1°C units, of the IGBT temperature feedback devices since the diagnostic data was last read. | | | | |
| 21 | MAX_IGBT_TEMP_B | SIGNED | | | | | |
| 22 | MAX_IGBT_TEMP_C | SIGNED | | | | | |
| 23 | CIB TEMPERATURE | SIGNED | The CIB temperature in 1°C units. Sampled when read. | | | | |
| 24 | DC_VOLTS | SIGNED | The current value, in 0.1V units, of the measured DC link voltage. Sampled when read. | | | | |
| 25 | MAX_DC_VOLTS | SIGNED | The maximum value, in 0.1V units, of the measured DC link voltage since the diagnostic data was last read. | | | | |
| 26 | STATUS | BIT FIELD | BIT 0: TRIPPED | BIT 1: ENABLED | BIT 2: FAN FAIL | | |
| | | | OTHER BITS: ZERO | | | | |
| | | | | | | | |
| | | | | | | | |
| 27 | SENSOR 1 | UNSIGNED | The AEI has three internal sensors, CURRENTLY UNUSED, able to measure 0-10V signals from a variety of optional sensors. | | | | |
| 28 | SENSOR 2 | | These registers give the sensor values, in 1mV units. | | | | |
| 29 | SENSOR 3 | | Sampled when read. | | | | |
| 30 | UNUSED | UNSIGNED | These words are stuck at ZERO. | | | | |
| 31 | | | | | | | |

8.4 MODBUS Sample Mode

Standard Mode (RS485 SW4 OFF)

- In this mode, the data to be transmitted in response to a MODBUS query is sampled as soon as a valid query, addressed to the slave address set by SW1 to SW3, is received.
- Once sampled, data is transmitted immediately.

Simultaneous Sample Mode (RS485 SW4 ON)

- In this mode, the data to be transmitted is sampled when a valid MODBUS query *addressed to slave address 01* is detected, independent of the slave address set by SW1 to SW3.
- The sampled data is not transmitted until a valid MODBUS query, addressed to the slave address set by SW1 to SW3, is received.
- In this mode, all AEI's on a single bus will sample their data simultaneously.
- Things to note:
 - This switch has no effect on the AEI configured to be slave address 01.
 - If slave address 01 is not polled by the MODBUS master, then no data will be sampled by any unit on the bus.
 - If a data error occurs on one of the units being commanded to sample, it will not do so but no MODBUS exception will be created. This circumstance should be vanishingly rare and may be detected by incoherent MODBUS TIMER data in the transmitted response.

9. Document Revision History

| Rev. | Date | Author | Changes |
|------|-----------|-----------|--|
| 00 | 3/14/2016 | Gary Pace | Document created |
| 01 | 5/18/2016 | Gary Pace | Default options for DIP switches changed & documented |
| 02 | 8/8/2016 | Gary Pace | Additional environmental specifications given DC link capacitance corrected |
| 03 | 12/1/2016 | Gary Pace | Models changed to AEI900L and AEI1000L |
| 04 | 1/4/2017 | Gary Pace | SW9 function added Minor stylistic changes throughout |

| Rev. | Date | Author | Changes |
|------|-------------|-----------|--|
| 05 | 7/17/2017 | Gary Pace | Note about negative CIB temperature added SW5 functionality changed Fault code descriptions changed Analog output modes changed SW9 function removed |
| 06 | 10/5/2017 | Gary Pace | Details for AEI1250L and AEI1400L added Internal fan failure description changed |
| 07 | 5/29/2018 | Gary Pace | Capacitance value for AEI1250L changed Program version LED display described Internal Fault codes defined in more detail |
| 08 | Aug 22 2018 | Gary Pace | More explanation about current on LED display provided MODBUS RTU function implemented |
| 09 | Feb 22 2021 | Gary Pace | Voltage Grade “2” in numbering scheme is 525V not 480V Statement that Avid must approve any auxiliary power supply other than AEI-APU Information for REV M interface board included MODBUS Sample Mode included Fault codes 35 & 36 defined Special Options information included in Model Number |
| 10 | Aug 3 2021 | Gary Pace | Section 8 correctly describes RS485 isolation on newer units Warning time changed from 5 to 8 minutes |
| 11 | Nov 17 2021 | Gary Pace | Plumbing options correctly described in section 3.4 |
| 12 | Mar 24 2022 | Gary Pace | Recommended torque for power connections added in section 4 |
| 13 | Aug 14 2023 | Gary Pace | Instruction to remove 40-way ribbon protector included |
| 14 | Sep 25 2023 | Gary Pace | CIB TB4 & TB5 plugs are not factory-fitted. AEI1250L is rated for 975V not 1100V DC link |