

REV: 11
December 12th 2023

Avid Controls Inc.
41261 Park 290 Drive, Waller, TX 77484, USA
info@avidcontrolsinc.com
(+1) (281) 640-8600

**THIS DATA SHEET CONTAINS AN INSTALLATION CHECKLIST THAT MUST BE
COMPLETED AND RETURNED TO INFO@AVIDCONTROLSINC.COM
SEE APPENDIX B**

AVID Controls Inc. pursues a policy of continuous product improvement and innovation. This may not be the latest revision of this publication and may not reflect all current product changes. Contact AVID Controls Inc. for the latest revision of this data sheet and information on other product enhancements.

INTENTIONALLY BLANK

Contents

1. Introduction	4
2. WARNINGS	4
3. Tools and Equipment Required.....	5
4. Necessary Avid Supplied Bill of Materials.....	5
5. Upgrade Kit Parts List.....	6
6. DC Fuses for Inter-Module Connection.....	8
7. Overview of SWP Type 27 Cabinet Layout.....	9
8. Prior to Removal of MVDL800 Delta Modules.....	10
9. Remove, Clean and Retain Cabinet Shrouds.....	12
10. Disconnect MVDL800 DELTA Modules	13
11. Remove MVDL800 DELTA Modules, Replace Hoses	14
12. Modify Side Panel of Grid Cabinet (Cubicle 1 A12-1) & Replace Inner Cubicle Bonding Bracket ..	15
13. Install AEI900L/AEI1000L Modules.....	16
14. Connect Coolant Hoses, Front and Back.....	18
15. Reinstall DC Cables, Busbars and Fuse Links	19
16. Reinstall A12-1 Side Phase Cables	20
17. Reinstall A12-2 AC Cables	21
18. Reinstall AEI Cover Plates.....	22
19. Install Auxiliary Power Units.....	23
20. Install Control Power Transformer (CPT).....	25
21. Install Cable Gland in A12-1 Inverter Cubicle	28
22. Install 690V Fuse Holder	29
23. Install 175V Terminal Block and Fuse Holder	30
24. Install Auxiliary-Power Wiring.....	31
25. Install Ground Brackets and Ribbon Cables	32
26. CDC IO Board Power Modification.....	34
27. Reinstall Lower Cubicle Shrouds.....	35
28. Reinstall Upper Cubicle Shrouds	36
29. Install Fuse and Breaker Labels	37
30. Turbine Restart.....	38
31. Label CDCs	40
32. Attach Documents for Reference	41
33. Fit the Upgrade Identification Label	42
34. Notes for Operation and Maintenance of Upgraded Turbine.....	42
35. Document Revision History	44
36. Appendix A – Optional Contactor for AEI Auxiliary Power Switching	45
37. Appendix B – Installation Checklist	47

AVID CONTROLS and the  logo are registered trademarks of Avid Controls Inc.

1. Introduction

- The following procedures are specific to the installation of the AVID AEI900L or AEI1000L liquid-cooled inverter module.
- These procedures detail how to upgrade a Siemens Wind Power 2.3MW Type 27 turbine from GE Power Conversion Delta modules to AEI (Avid Extreme Inverter) modules and associated installation kit.
- For reference, see the following AVID documents, which are supplied alongside this Installation Instruction:
 - DTS-MID0012 for additional specifications explicitly related to the AEI900L/AEI1000L units.
 - DTS-01944-ASY-A for additional specifications related to the enclosed Control Power Transformer.
 - DTS-MID0124 for additional specifications related to the Auxiliary Power Units

2. WARNINGS

- Always refer to the Cautions and Warnings in the associated MV DELTA and MV3000 manuals when installing / commissioning / fault-finding any system containing an AEI900L/AEI1000L module.
- This equipment may be connected to more than one live circuit.
- **Disconnect all power sources before working on the equipment.**
- **Wait at least 8 minutes after isolating all power sources and check that the voltage between DC+ and DC- has reduced to a safe level before working on the equipment.**
- Surfaces on the coolant pipes can reach high temperatures and remain hot for some time after power is switched off.
- Ensure that all coolant has cooled to a safe temperature and the equipment is suitably drained and isolated before disconnected the external pipework from the equipment.
- Figures are for reference only.
- It is recommended that all DC fuses are replaced during this upgrade – see section 6 for further details.
- Appendix B contains an installation checklist for the turbine upgrade. This must be completed and returned to info@avidcontrolsinc.com to activate the individual product warranties for the Avid equipment. Each field in the checklist requires either initials, the recording of specific information (such as parameter values) or “N/A” if not applicable.

3. Tools and Equipment Required

Wire Cutters	10mm Socket, 3/8" Drive
TORX T25 Driver	17mm Socket, 3/8" Drive
Phillips #2 x 4" Screwdriver	Socket Extension 10" Long, 3/8" Drive
3/16" x 4" Slotted Screwdriver	Adjustable Crescent Wrench, 1" Jaw Capacity
#3 Pozi-drive Screwdriver	½" Knockout Hole Punch For 7/8" Hole* ¹
Socket Wrench, 3/8" Drive	Power Impact Tools (DeWalt or similar)
Torque Wrench, 3/8" Drive	5/16" Drill Bit
5mm Socket, 3/8" Drive	1/2" Drill Bit
8mm Socket, 3/8" Drive	Center Punch
MV3000 Keypad with cable	Shop Vacuum
10" long ¼" drive socket extension* ²	T-Handle torque wrench, pre-set to 4 Nm* ²
¼" drive 8mm socket* ²	Hex shank to ¼" drive adapter* ²
Suitable tool (screwdriver) for wire release/insertion on spring clamp terminals	Sheet metal / Lexan cutting tool (Dicfeos REX003 Double Head Sheet Nibbler or similar)

***1: Provided as part of the upgrade kit. Used to punch holes for mounting of CPT.**

***2: Provided as part of the upgrade kit. Used to secure and torque coolant hose clamps.**

4. Necessary Avid Supplied Bill of Materials

AVID Model Number	Qty.	Description
AEI900L-412100-00-[N]/[S]/[R] * ³	6	Avid Extreme Inverter, 900A 690V, Plumbing Option A, without capacitor fans, [N]=New, [S]=Enhanced Reman., [R]=Reman.
OR		
AEI1000L-412100-00-[N]/[S]/[R]* ³	6	Avid Extreme Inverter, 1000A 690V, Plumbing Option A, without capacitor fans, [N]=New, [S]=Enhanced Reman., [R]=Reman.
AEI-UPGR-KIT-02	1	AEI Upgrade Kit. For SWP 2.3MW Type 27 Class Turbines

***3: Depending on the rating of the upgraded turbine, AEI900L or AEI1000L modules may be used**

5. Upgrade Kit Parts List

Item Reference	Qty.	Description
1	2	Master Auxiliary Power Unit, Avid Model Number AEI-APU-E-00
2	4	Slave Auxiliary Power Unit, Avid Model Number AEI-APU-F-00
3	1	Control Power Transformer, Single Phase, 480/600/690V to 175V, 50/60HZ, 2000VA, Enclosed, Avid Model Number AEI-UPGR-CPT-01
4	1	Magnetically Attached Document Envelope
5	2	Identification Label for Upgraded Turbine
6	2	Ribbon cable ground bracket
7	6	HOSE FOR FRONT MANIFOLD, STRAIGHT 183mm LONG, HOSE ID 20mm
8	6	HOSE FOR REAR MANIFOLD, STRAIGHT 275mm LONG, HOSE ID 20mm
9	24	Hose clamps
10	5	TEE CONNECTOR FOR 0.25in ID TUBE, WHITE NYLON PLASTIC
11	1	ELBOW CONNECTOR FOR 0.25in ID TUBE, WHITE NYLON PLASTIC
12	1	Fuse Holder, 2-Pole Ultra-safe, 690V, 125A, for 22mm x 58mm Fuse Links, with Indicator and Auxiliary Microswitch. MERSEN part number US222M2I.
13	1	Fuse Holder, Single-Pole Ultra-safe, 750V, 50A, for 14mm x 51mm Fuse Links, with Indicator and Auxiliary Microswitch. MERSEN part number US141MI
14	1	Fuse, 20A, 500VAC, 14mm x 51mm, with blown-fuse indicator striker. MERSEN part number FR14GG50V20P.
15	2	Fuse, 10A, 690VAC, 22mm x 58mm, with blown-fuse indicator striker. MERSEN part number FR22GG69V10P.
16	4	Cable gland, bush and seal nut - CGB
17	1	DIN rail mounted terminal block, feedthrough, grey
18	2	DIN rail mounted terminal block, grounding, yellow/green
19	3	DIN rail mounted terminal block, terminal end cover, grey
20	6	DIN rail mounted terminal block, end-stop, grey
21	1	Cable assembly, 60-in, 2-conductor, 1000Vac 2.5mm ² , black outer jacket For connection from 690V CB to fuse holder
22	1	Cable assembly, 60-in, 2-conductor, 1000Vac 2.5mm ² , black outer jacket For connection from 690V fuse holder to CPT primary
23	1	Cable assembly, 11-ft, 3-conductor, 300Vac 2.5mm ² , black outer jacket For connection from CPT secondary to 175V fuse holder etc.
24	1	Cable assembly, 20-ft, 3-conductor, 300Vac 2.5mm ² , black outer jacket For connection from 175V fuse holder etc. to GEN. APU

Item Reference	Qty.	Description
25	1	Cable assembly, 15-in, 3-conductor, 300Vac 2.5mm ² , black outer jacket For connection from GEN. APU to GRID APU
26	1	Cable assembly, 24-in, 2-conductor, 600Vac 14AWG, black outer jacket For connection between GEN-1 APU & GEN-2 APU
27	1	Cable assembly, 36-in, 2-conductor, 600Vac 14AWG, black outer jacket For connection between GRID-1 APU & GRID-2 APU
28	1	Cable assembly, 54-in, 2-conductor, 600Vac 14AWG, black outer jacket For connection between GEN-1 APU & GEN-2 APU
29	1	Cable assembly, 54-in, 2-conductor, 600Vac 14AWG, black outer jacket For connection between GRID-1 APU & GRID-3 APU
30	2	Label, Red, "Caution External Control Voltage"
31	2	Label, Black, "Converter Control Power"
32	20	Bolt, M5 x 10mm, Taptite, Pozi-pan, Steel, Zinc Plated
33	20	Self-adhesive cable tie bases, 1-in x 1-in
34	100	11-in black cable ties, 50lb
35	100	5-in black cable ties, 30lb
36	20 ft	PVC BRAIDED TUBING, 0.25in ID
37	2	Splicing connector; with operating levers; 12 AWG; transparent housing
38	1	Pack of IPA cleaning wipes
39	1	Tube of orange torque-seal paint
40	1	Grounding bracket for inner cubicles

6. DC Fuses for Inter-Module Connection

- All Siemens Wind Power (and Siemens Gamesa Renewable Energy) 2.3MW and 3.6MW turbines configure the Delta/AEI modules in hard-paralleled “sister” units, with relatively small rating DC fuses to interconnect the “sisters”.
- Experience has shown that these fuses age with time, and that faults in the Delta modules can accelerate this aging – often leading to premature failure.
- It is therefore strongly recommended that these fuses always be replaced when this upgrade is performed.
- Failure to do so may result in failure of the fuses shortly after re-starting the turbine.
- These fuses are standard spares for all wind sites, so are not provided as part of the upgrade kit.

7. Overview of SWP Type 27 Cabinet Layout

Cabinet Section (See Plan View)	Contains
REACTOR	Main Grid Reactor
A12 GRID & GEN CONVERTER	Grid Generator Deltas, CDCs, and SMPS's
A1	Incoming Power F/ Low Voltage, Large Circuit Breakers & Transformers
MAIN BREAKER	Siemens Control
Control	Fuses, Circuit Breakers, Ethernet & Fiber Optic

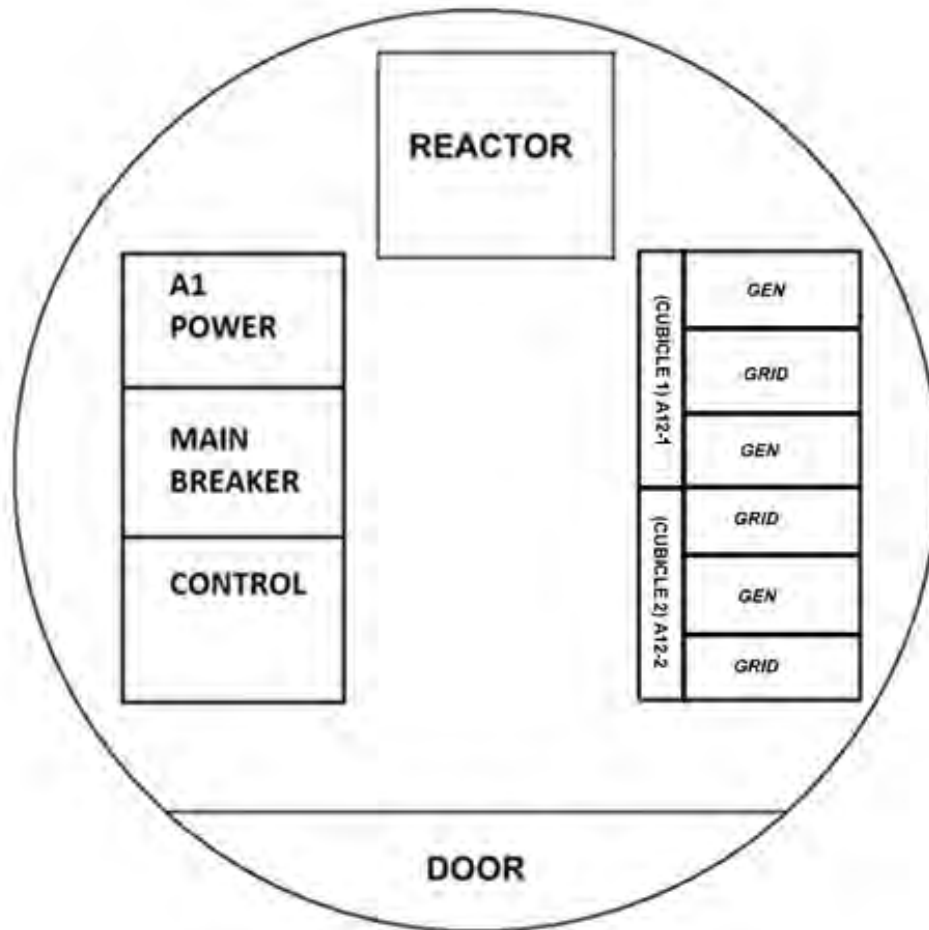

Plan View

8. Prior to Removal of MVDL800 Delta Modules

- The removal process of the GE Power Conversion MVDL800 Delta modules should follow standard on-site processes, including:
 - Power shutdown
 - Draining of liquid coolant
 - Disconnecting of all electrical power sources
 - Removal of SMPS
 - Removal of the MVDL800 Deltas
- Before removal of any connections or components, record the positions of the following.
 - All existing cables
 - Note the position of any relevant tie wraps
 - Identify the master SMPS for the grid and generator system. The master SMPS is mounted on the Delta module connected to PL2 of the associated CDC.
 - Keep all hardware, nuts, bolts, washers, thread protectors, etc.

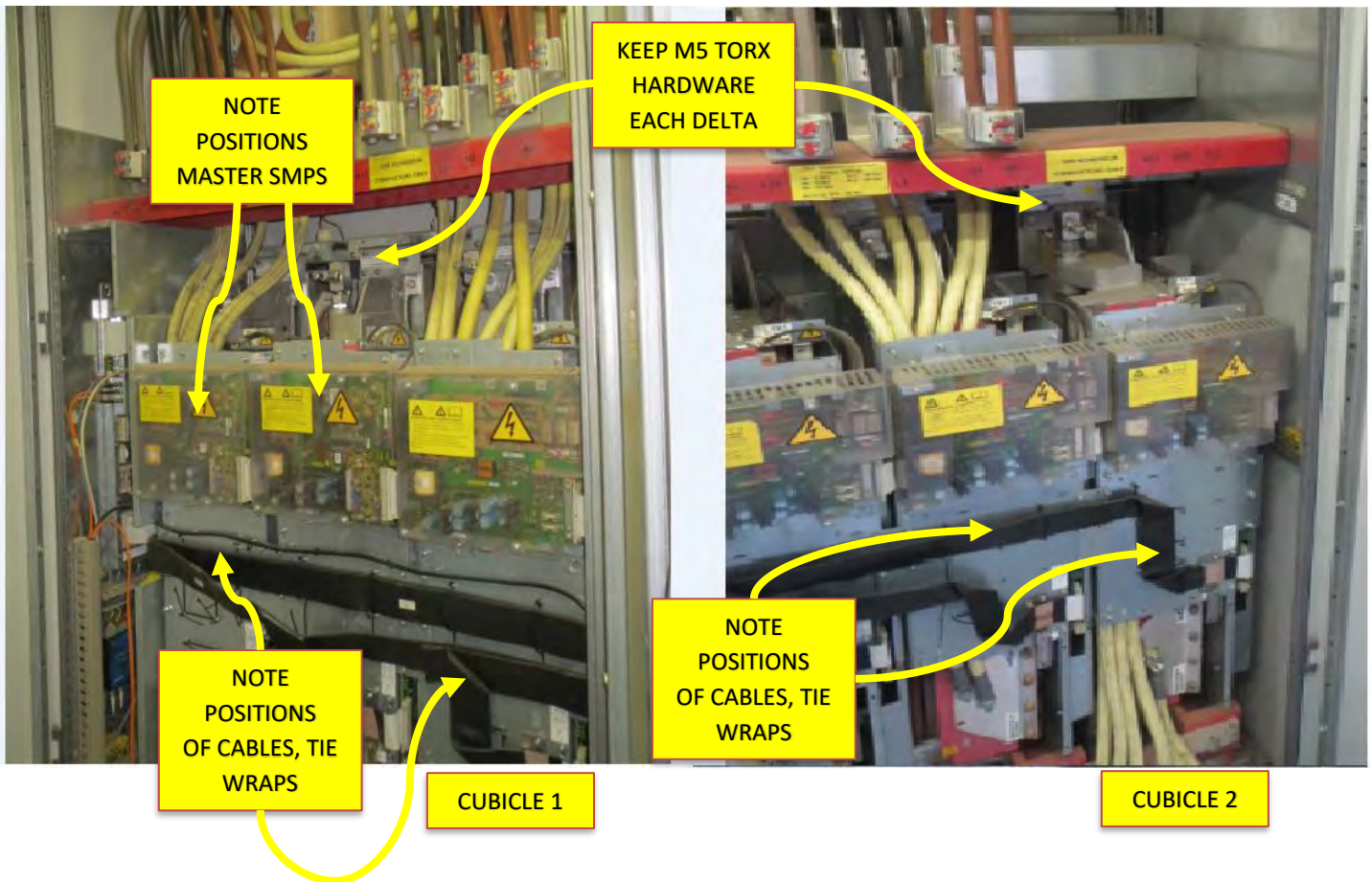

- When removing the Master SMPS(s), record the positions of jumpers TP10 to TP13. These jumpers configure the over-voltage trip behavior. The AEI900L/AEI1000L modules use this information for proper setup.

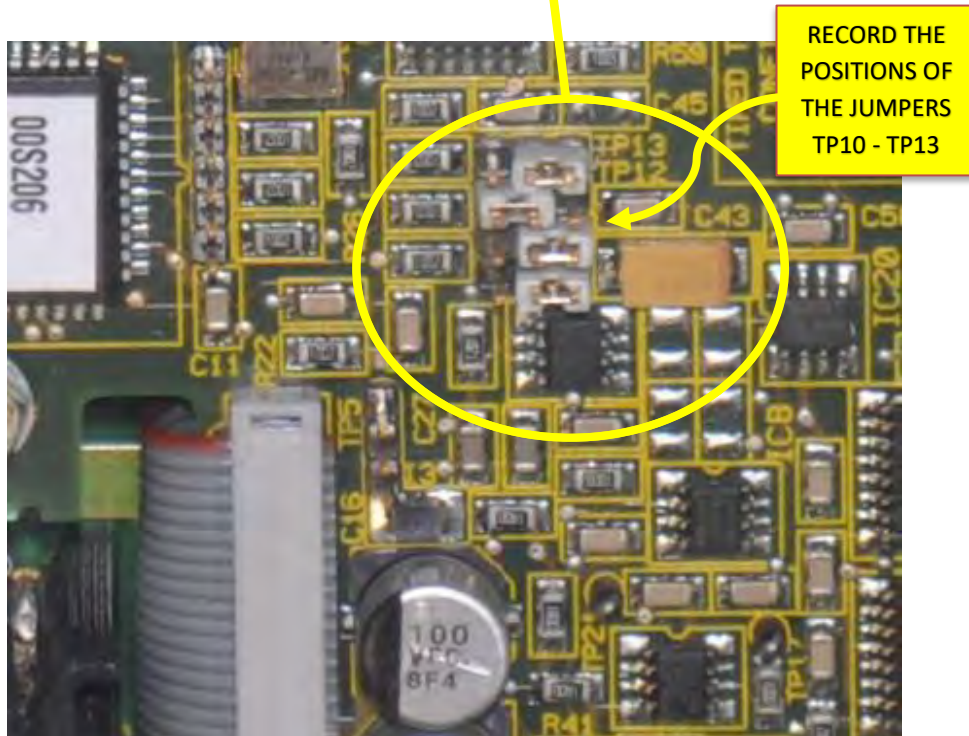
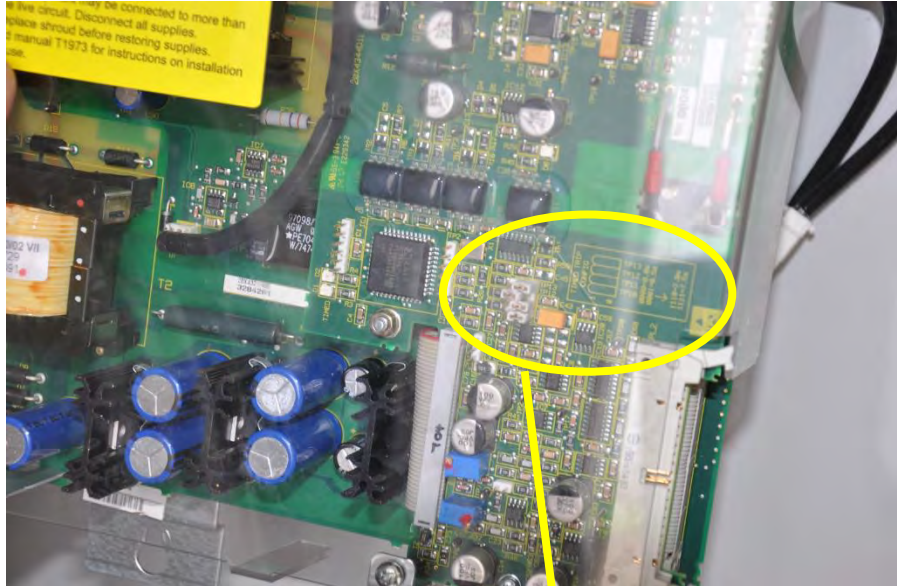

9. Remove, Clean and Retain Cabinet Shrouds

- Remove the upper and lower polycarbonate shrouds from the front of the GEN and GRID cabinets.
- Retain the shrouds for re-fitting after AEI installation.
- Retain the fixing screws
- ***It is highly recommended to clean these shrouds thoroughly before re-installation. A pack of cleaning wipes is included in the upgrade kit.***

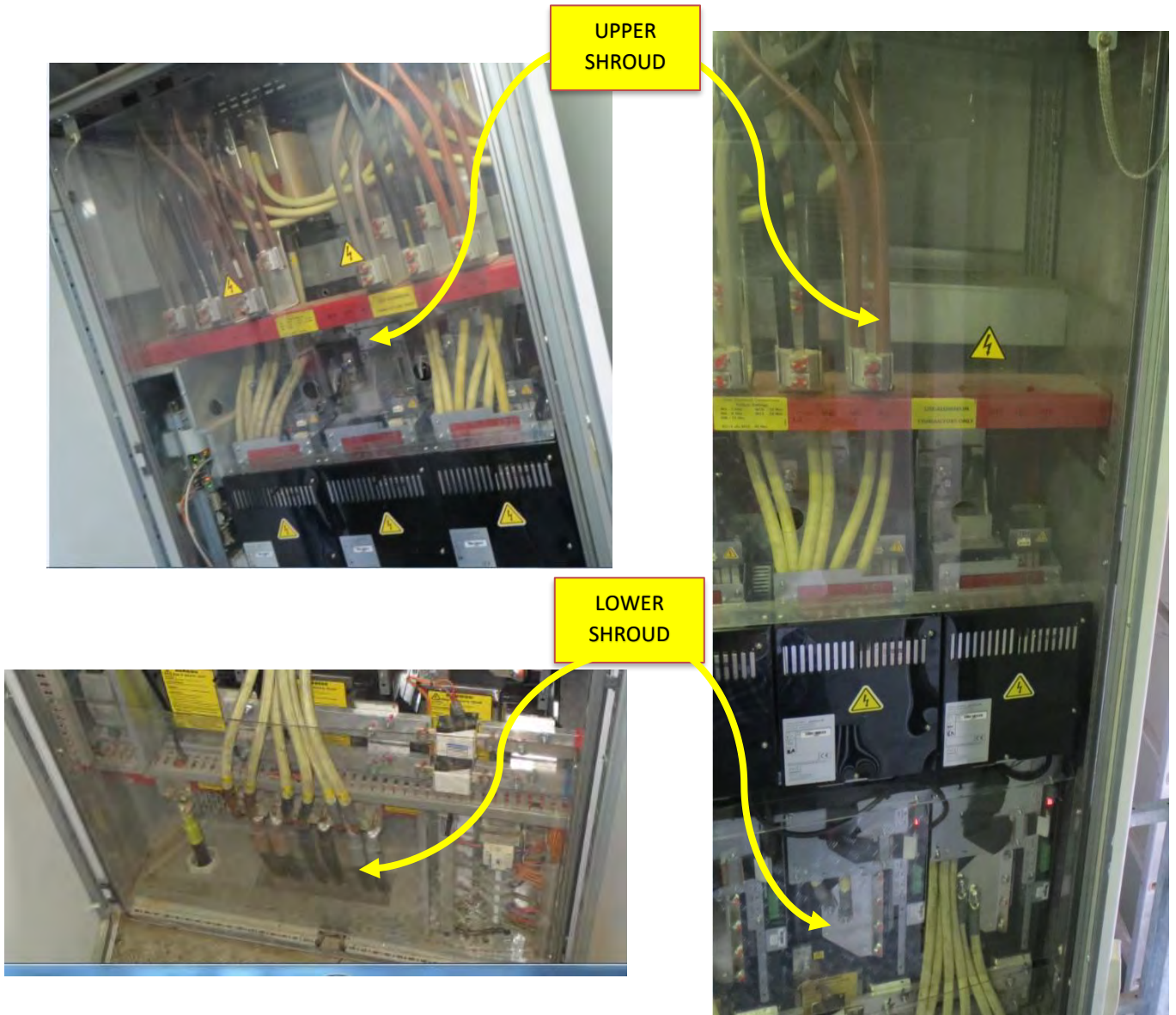

10. Disconnect MVDL800 DELTA Modules

- Disconnect and remove all ribbon cables; carefully retain these for installation of AEI units.
- Remove all SMPS Modules and SMPS mounting plates.
- Carefully note all power cable positions, then remove them:

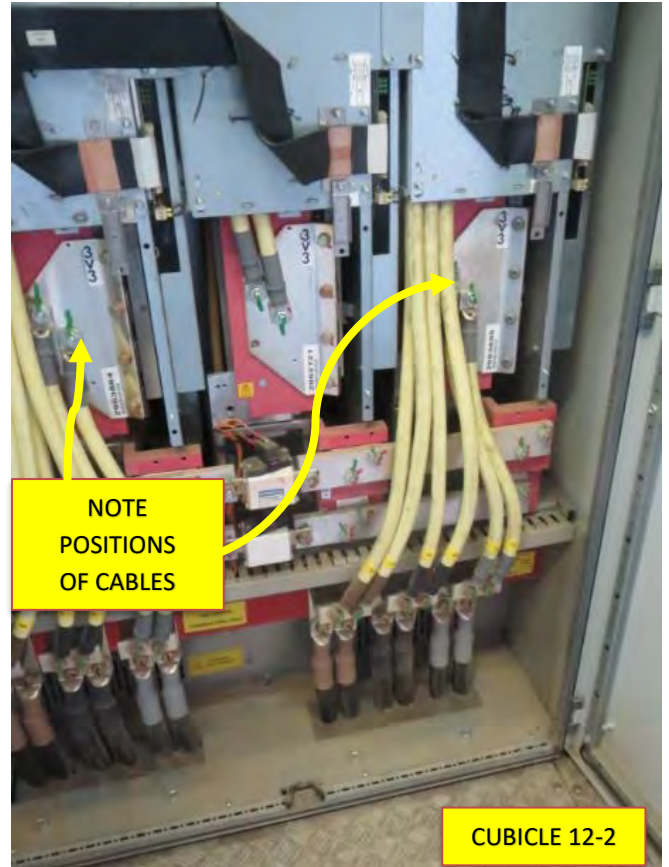
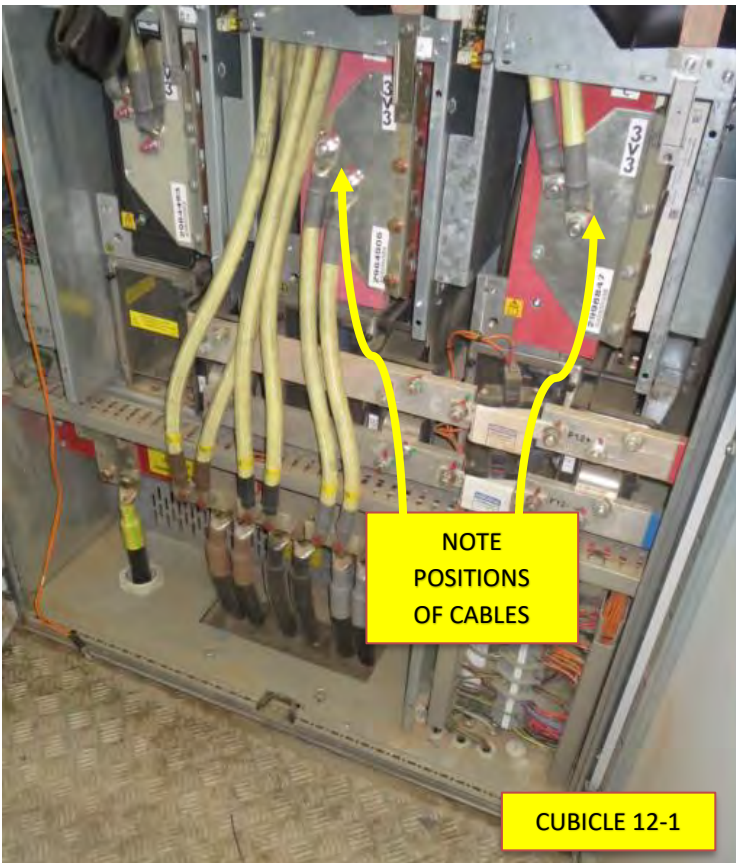

11. Remove MVDL800 DELTA Modules, Replace Hoses

- Remove all DELTA modules as shown; this will allow access to the rear and front hoses, as shown below.
- Replace all 12 hoses using hoses and clamps provided in the AEI upgrade kit, taking care to ensure their orientation matches that of the removed hoses.

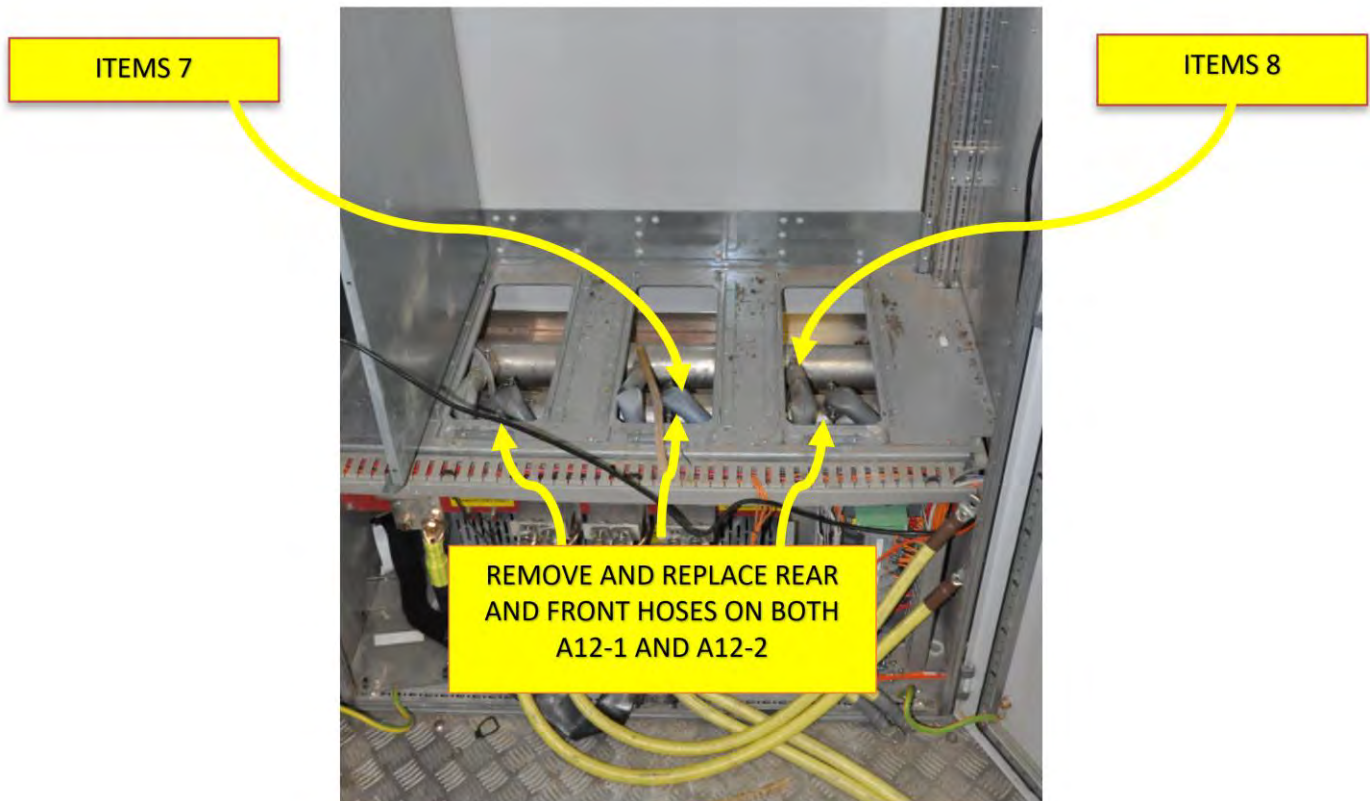

- Tighten all hose clamps to 4Nm torque. A pre-set torque handle is provided in the upgrade kit for this purpose.
- **IT IS CRITICAL THAT THE HOSES ARE SECURELY INSTALLED AND THE CLAMPS TIGHTENED CORRECTLY. COOLANT LEAKAGE WILL IRREPARABLY DAMAGE THE INVERTER UNITS.**

12. Modify Side Panel of Grid Cabinet (Cubicle 1 A12-1) & Replace Inner Cubicle Bonding Bracket

- To allow installation of new grounding bracket and ribbons, remove the metal section from the left-hand shielding panel as shown below.
- DO NOT remove panel from cabinet, implement modification with panel in-situ.
- Ensure suitable precautions are taken to prevent metal particles (swarf) from contaminating the cabinet.
- Remove and replace inner cubicle bonding bracket with Item 40 provided in the upgrade kit.

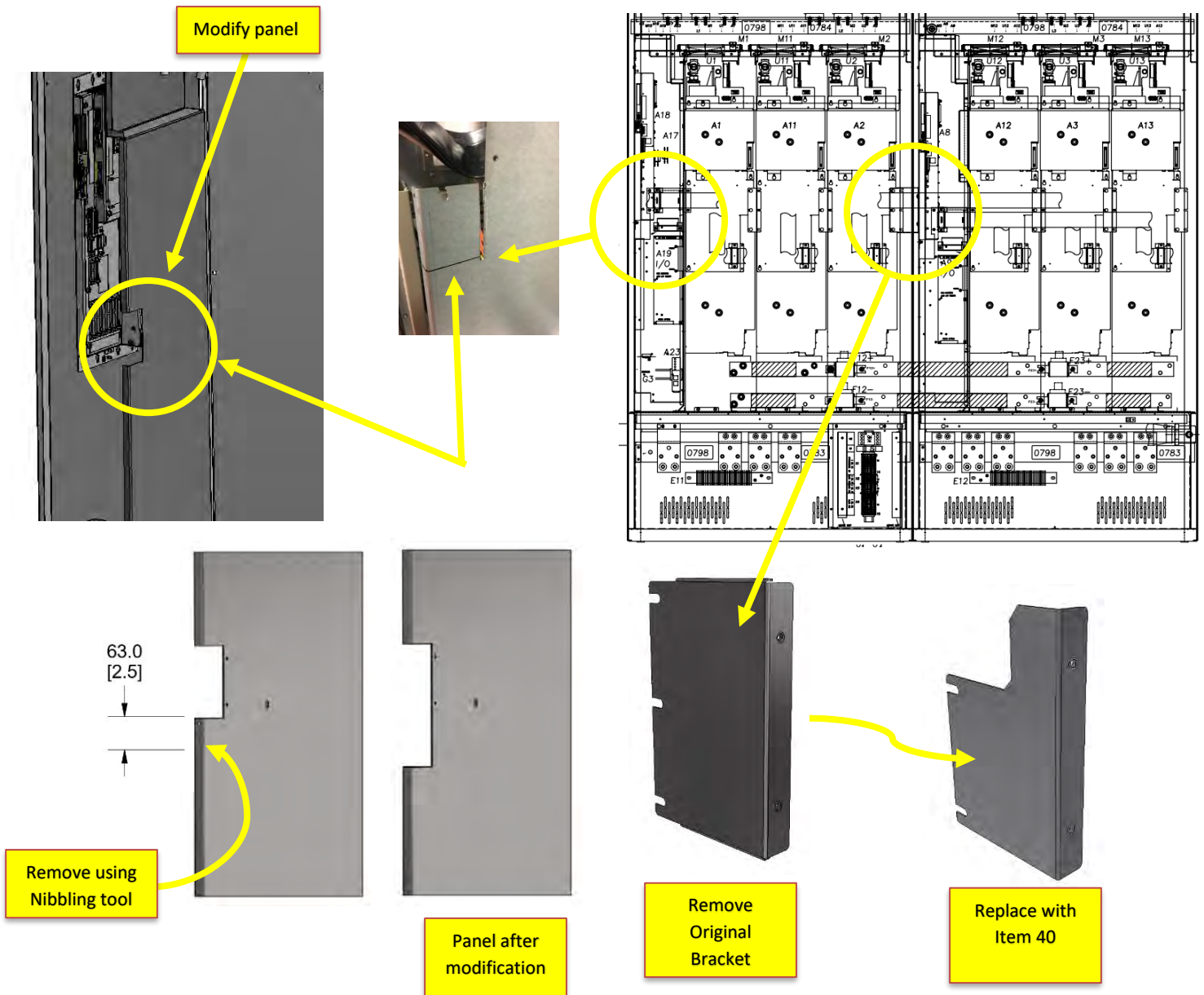

13. Install AEI 900L/AEI 1000L Modules

- Before the Installation of *each* AEI verify that DIP switches 1-4 (which configure the overvoltage behavior) on each AEI are set to the equivalent time setting as recorded in Step 8 - Master SMPS Jumpers TP10 to TP13

SMPS Jumpers	AEI Switch
TP10	SW1
TP11	SW2
TP12	SW3
TP13	SW4

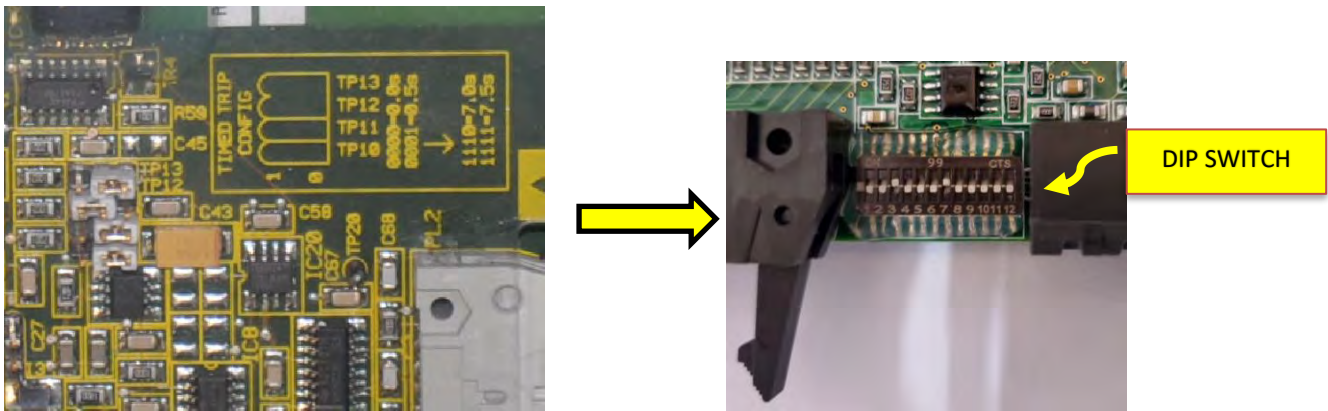

- Correctly set SW7 for the Compatibility Rating Mode required:

AEI Module Used	Upgraded Turbine Converter Current Rating	Position of SW7
AEI900L	2400 A (as before upgrade)	ON
AEI900L	2700 A	OFF
AEI1000L	3000 A	OFF

- Refer to AVID Document DTS-MID0012 section on User Selectable Options for complete information about these settings.

THESE SETTINGS ARE IMPORTANT, THE TURBINE WILL NOT RUN CORRECTLY UNLESS THEY ARE MADE.

- Install the 6 AEI's into the A12-1 and A12-2 cabinets.
- Align with the M5 and M6 mounting locations used by the DELTA modules, firmly secure the AEI units with the M5 Torx screws and M6 bolts/washers retained when the DELTA modules were removed.

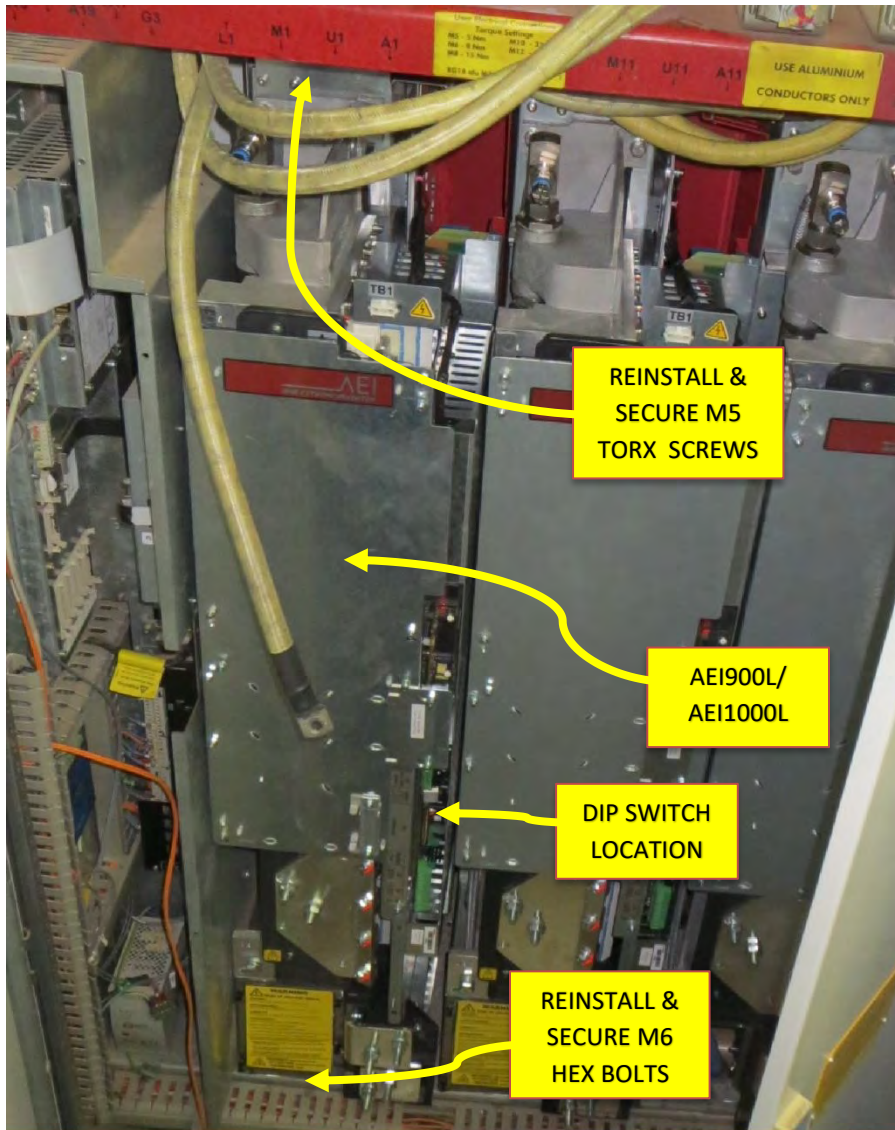

14. Connect Coolant Hoses, Front and Back

- Connect and secure each rear Plumbing Hose from the outlet manifold to the rear barb on all the AEI units.
- Connect and secure each hose from the inlet manifold to the front barb on all the AEI units



- **Tighten all hose clamps to 4Nm torque. A pre-set torque handle is provided in the upgrade kit for this purpose.**
- **IT IS CRITICAL THAT THE HOSES ARE SECURELY INSTALLED AND THE CLAMPS TIGHTENED CORRECTLY. COOLANT LEAKAGE WILL IRREPARABLY DAMAGE THE INVERTER UNITS.**

- Replace the splash shroud on each AEI

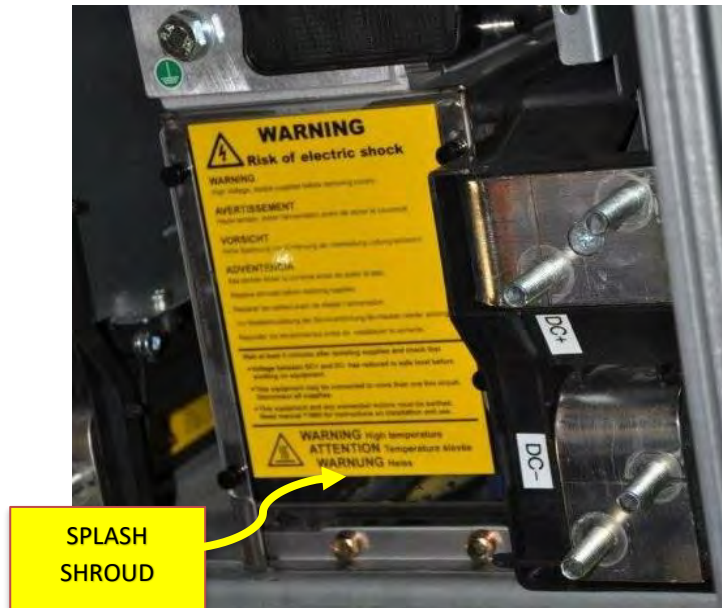

15. Reinstall DC Cables, Busbars and Fuse Links

- In Cubicle A12-1, reconnect all the DC negative and DC positive busbar to each AEI using the supplied M10 flange nuts and reusing the M10 hex bolt. Install the DC Link fuse busbar. Torque down all connections to 35Nm;



- In Cubicle A12-2, reconnect all the DC negative and DC positive busbar to each AEI using the supplied M10 flange nuts and reusing the M10 hex bolt. Install the DC Link fuse busbar. Torque down all connections to 35Nm.

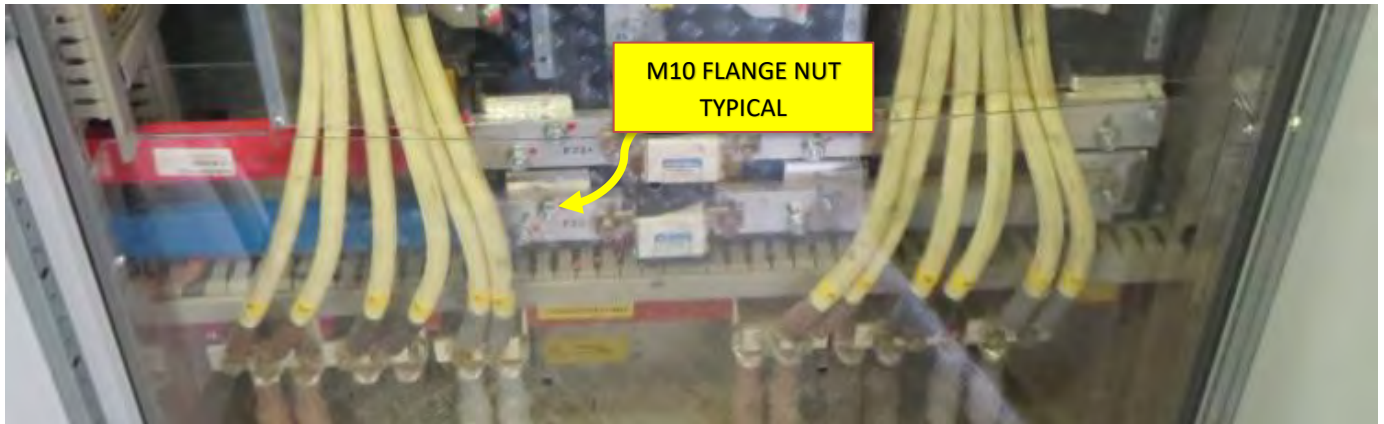

16. Reinstall A12-1 Side Phase Cables

- Remove the cover plates from each AEI.
- Install the A12-1 side phase cables as identified on removal, using the supplied M10 flange nuts. Torque all connections to 35Nm.

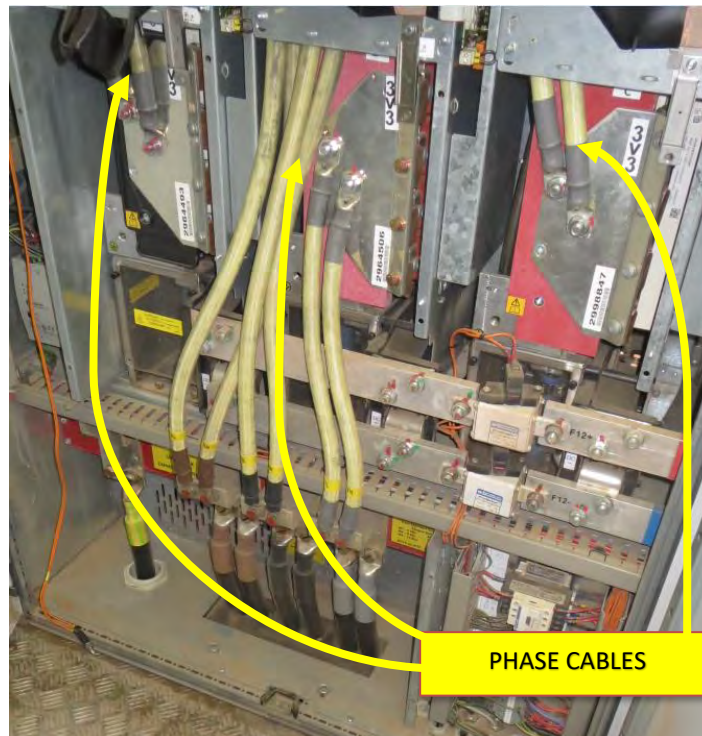

17. Reinstall A12-2 AC Cables

- Remove the cover plates from each AEI.
- Install the A12-2 side phase cables as identified on removal, using the supplied M10 flange nuts. Torque all connections to 35Nm.

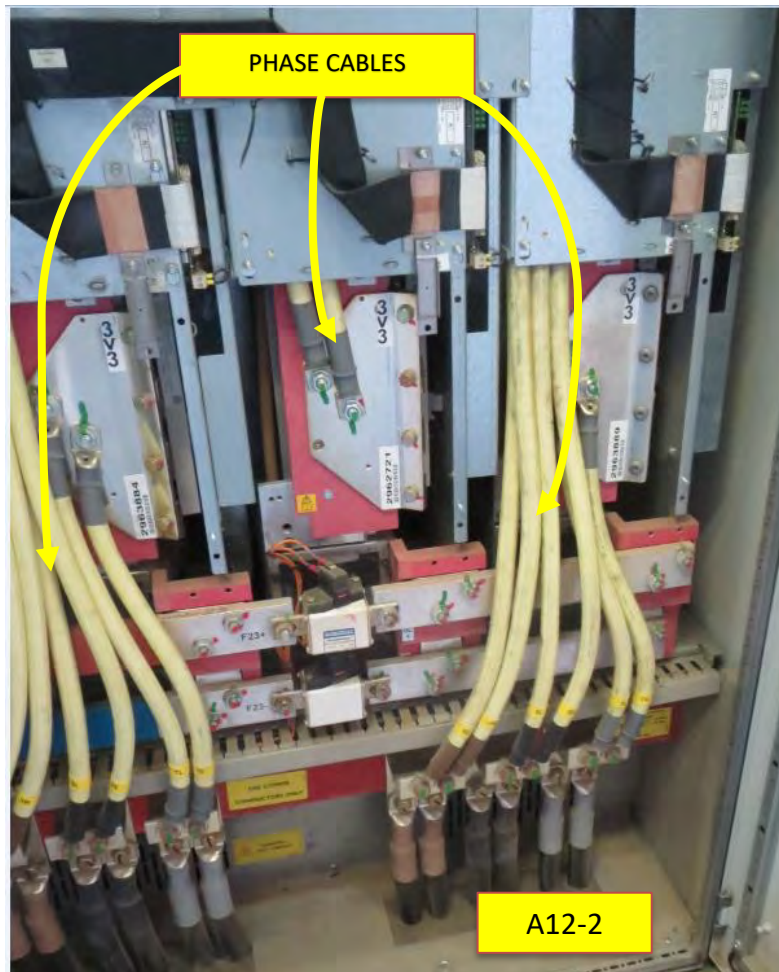

18. Reinstall AEI Cover Plates

- The following steps are the same for both GRID & GEN sides.
- Remount the cover plates to each AEI, as shown. Tighten down all M5 Hex Nuts firmly to secure to the AEI
- Remove, flip, and attach the EMC plates to join each adjacent AEI unit, and tighten down firmly with the provided M5 Hex Nuts

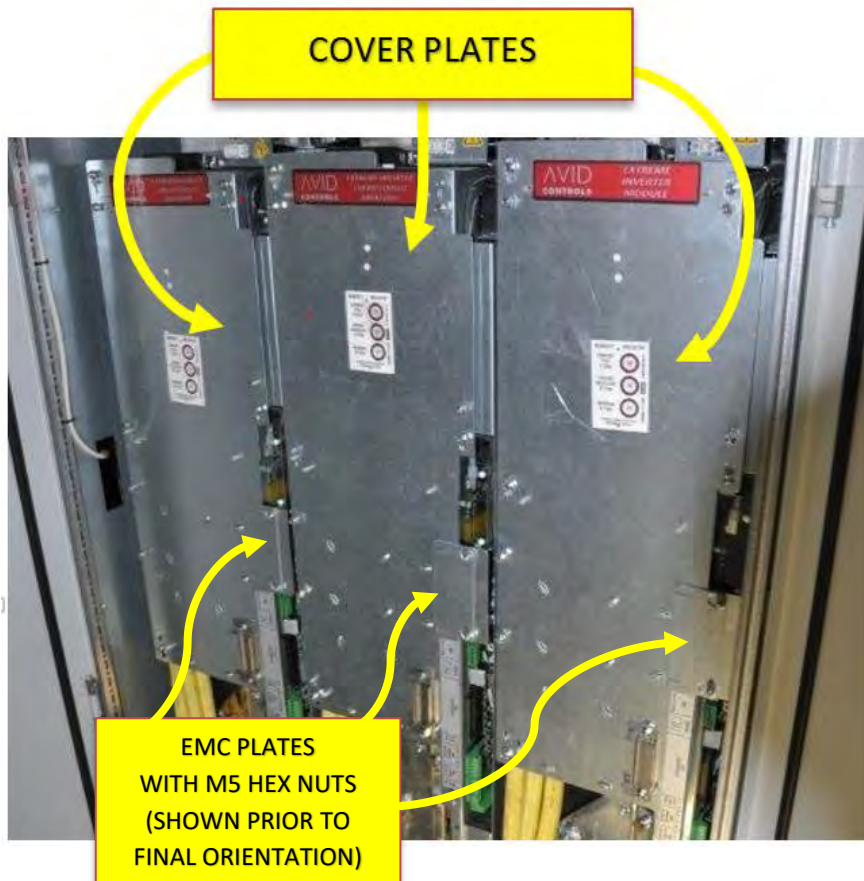

19. Install Auxiliary Power Units

- Mount the Auxiliary Power units onto the AEI Cover Plates.
- Mount the Master APU units (**Item 1**) onto AEIs GEN-1 & GRID-1 (the left-hand two AEIs in cubicle A12-1)
- Mount the Slave APU units (**Item 2**) onto AEIs GEN-2, GRID-2, GEN-3 & GRID-3
- Tighten the M5 Nylock nuts securely

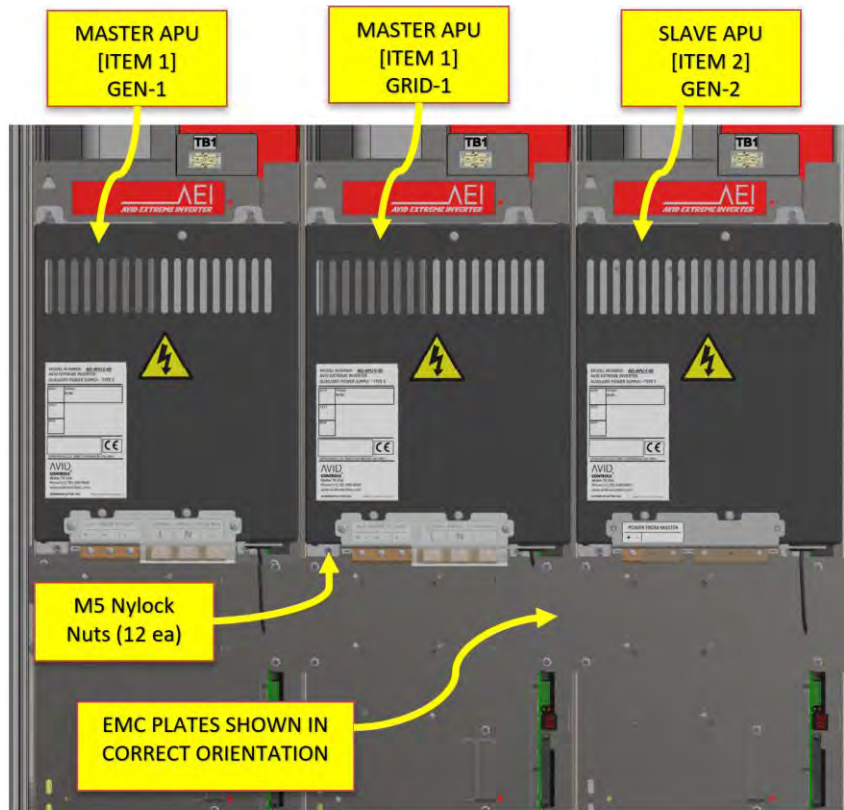

(CUBICLE 1) A12-1

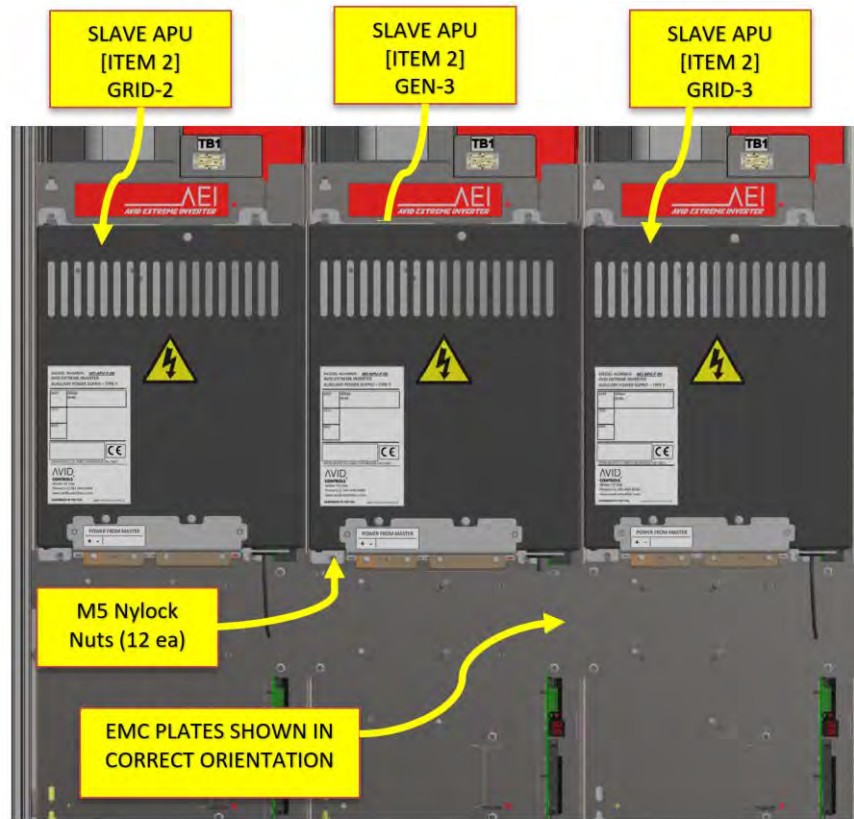

(CUBICLE 2)A12-2

- For each APU, plug the 4-pin connector into the corresponding AEI module:

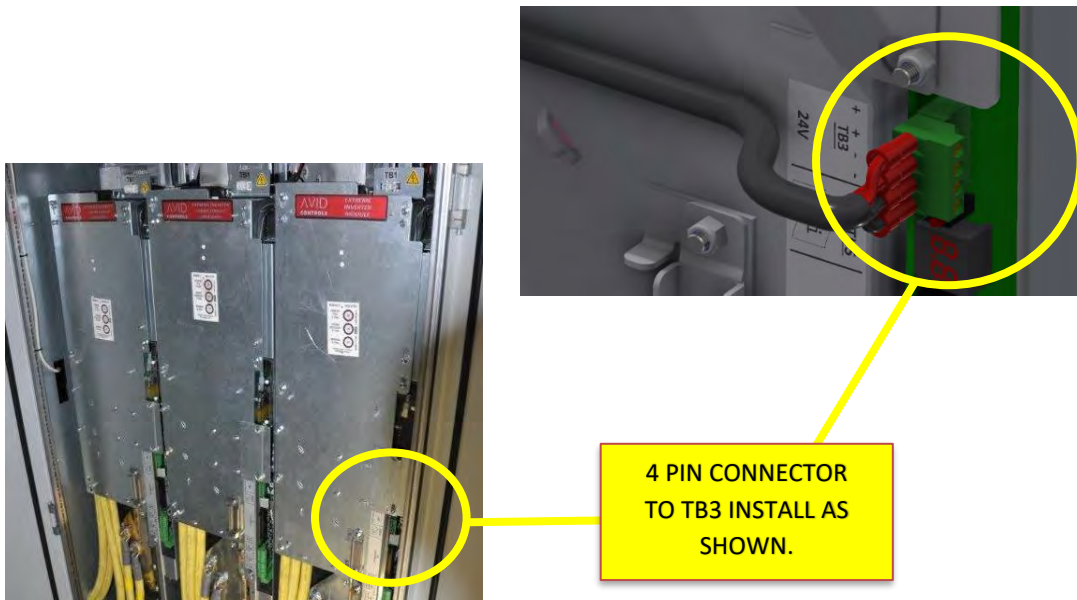

20. Install Control Power Transformer (CPT)



CAUTION: Note this stage will require the drilling and punching of holes to mount the transformer and cable fittings. Keep metal shavings from contaminating any internal electrical components using a drop cloth or similar.

- The Control Power Transformer (CPT) (*Item 3*) is to be mounted on the top of the A1 cabinet. It should be mounted close to the front and middle of this cabinet section.
- Remove the indicated panel from the CPT to provide access for mounting and wiring. Carefully retain the cover and fasteners

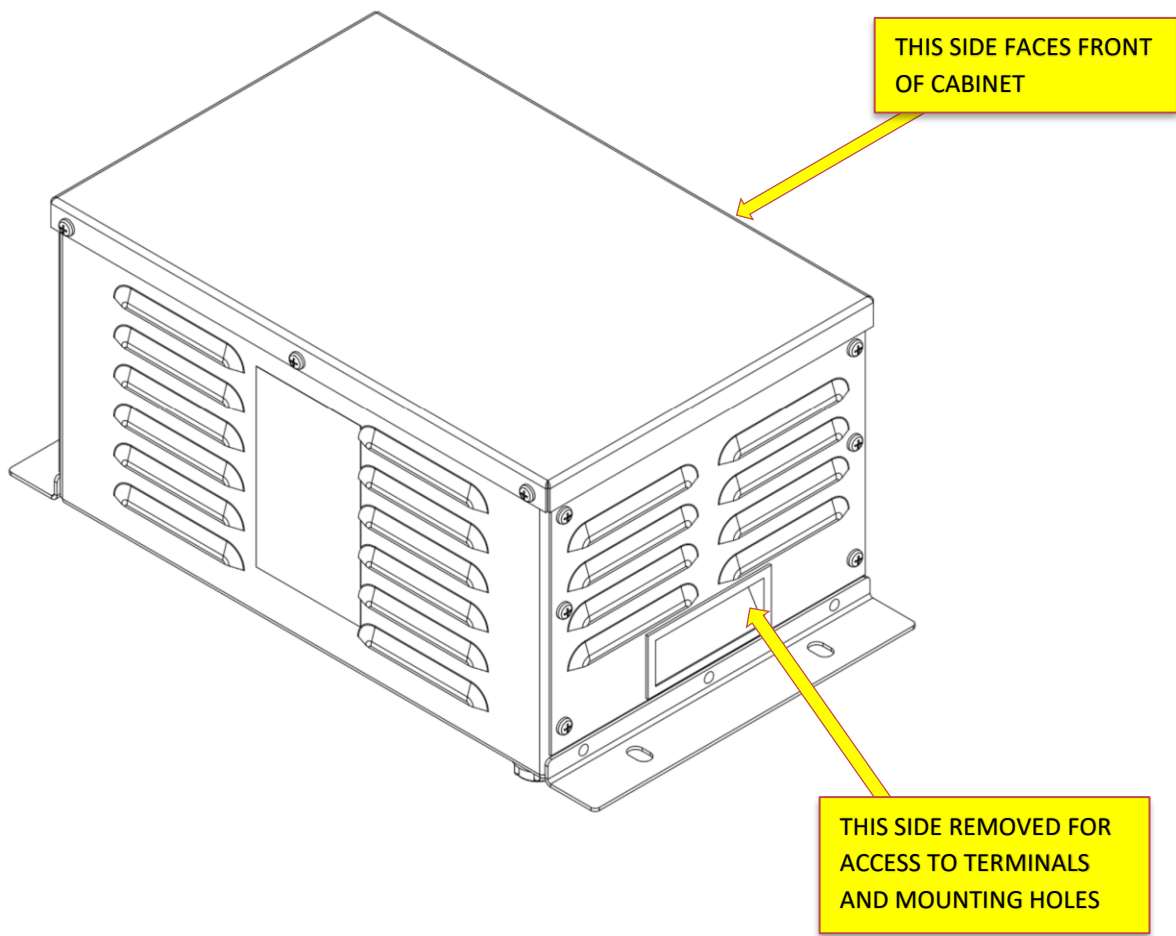

- Identify exactly where the CPT will be mounted on the top of the cabinet, and referring to the following drawing (the full-size version is in DTS-01944-ASY-A), use a 1/2" drill and the Knockout Hole Punch to make two 7/8" holes to line-up with the highlighted holes in the base of the CPT:

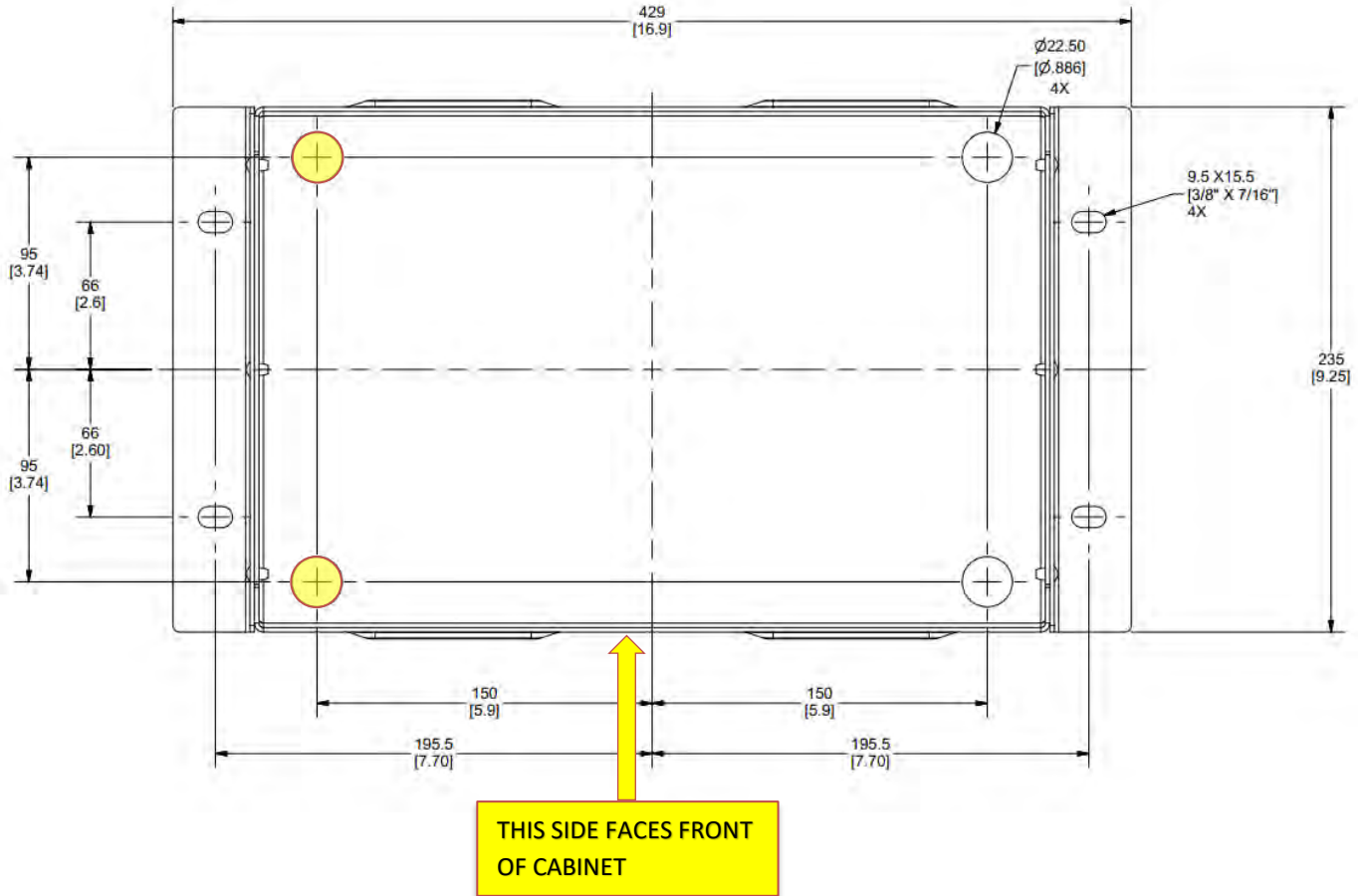

- Mount the CPT on the top of the cabinet, lining up the holes
- Install two sets of cable gland hardware (**Item 16**) to secure the CPT to the cabinet and provide access for cables:



- The following figure (from DTS-01944-ASY-A) shows the mountings and connections for the CPT:

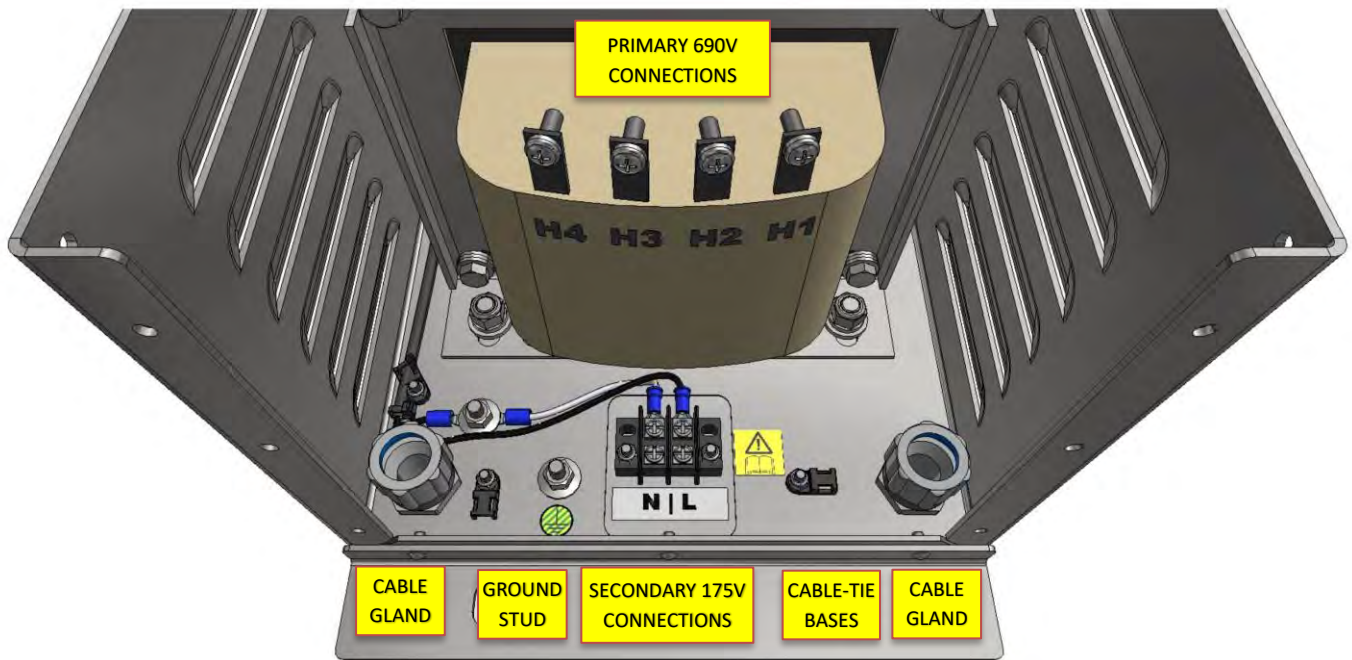

21. Install Cable Gland in A12-1 Inverter Cubicle

- Using a ½" drill and the Knockout Hole Punch, make a 7/8" hole in the base plate on the right side of the A12-1 cabinet, approximately 2" from the door and side panels
- Install a cable gland hardware in the hole:

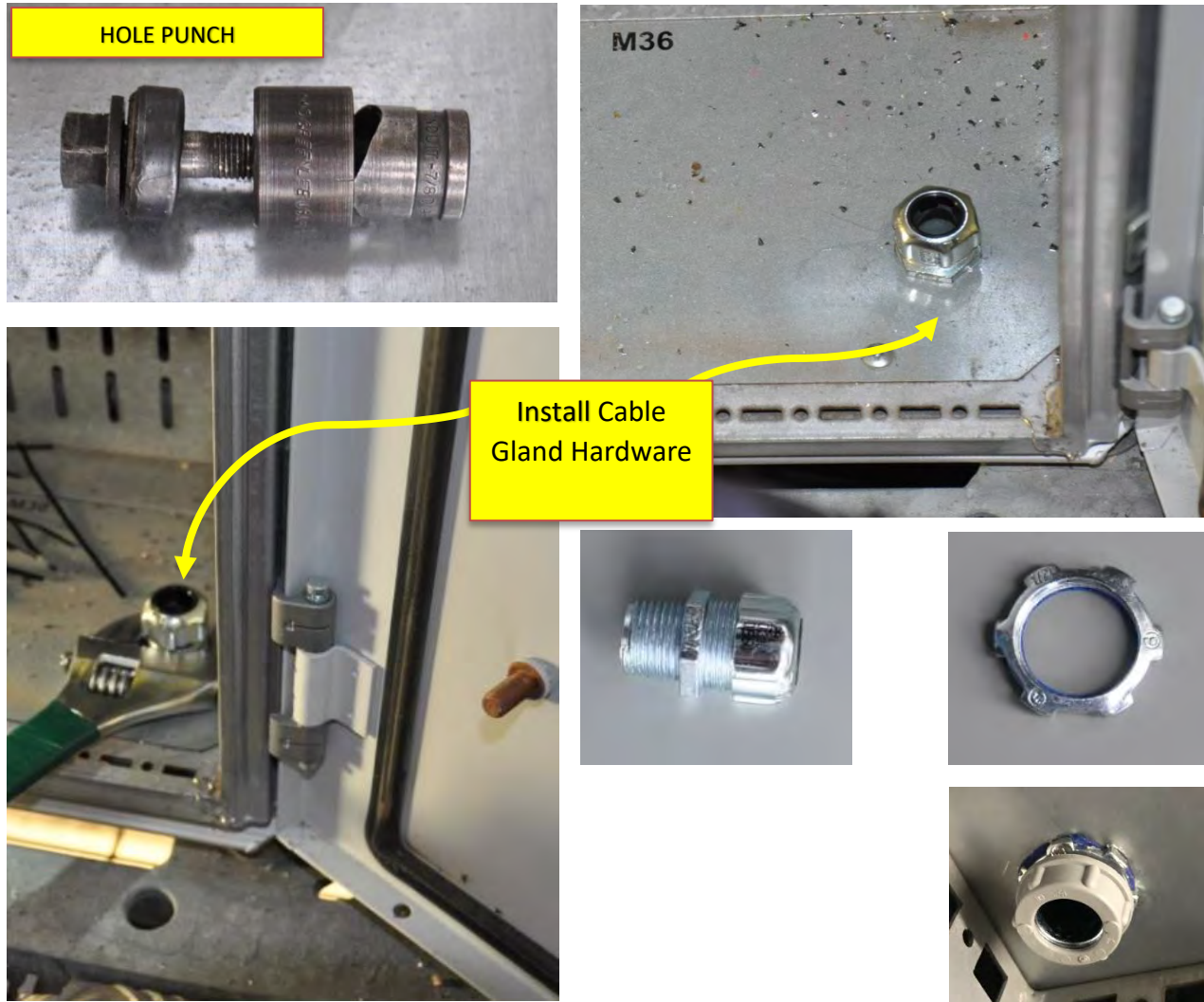

- Carefully vacuum all metal shavings
- The cable gland will be used to run the 175VAC supply from the Control Power Transformer to the Master Auxiliary Power Unit1 – see section 24.

22. Install 690V Fuse Holder

- On the top - left side of cabinet A1, install the 2-pole 690V ultra-safe fuse holder (**Item 12**) and Fuses (**Item 15**).
- If available, use an extra length of the existing DIN-rail; if none is available, then mount a small additional length for this purpose.

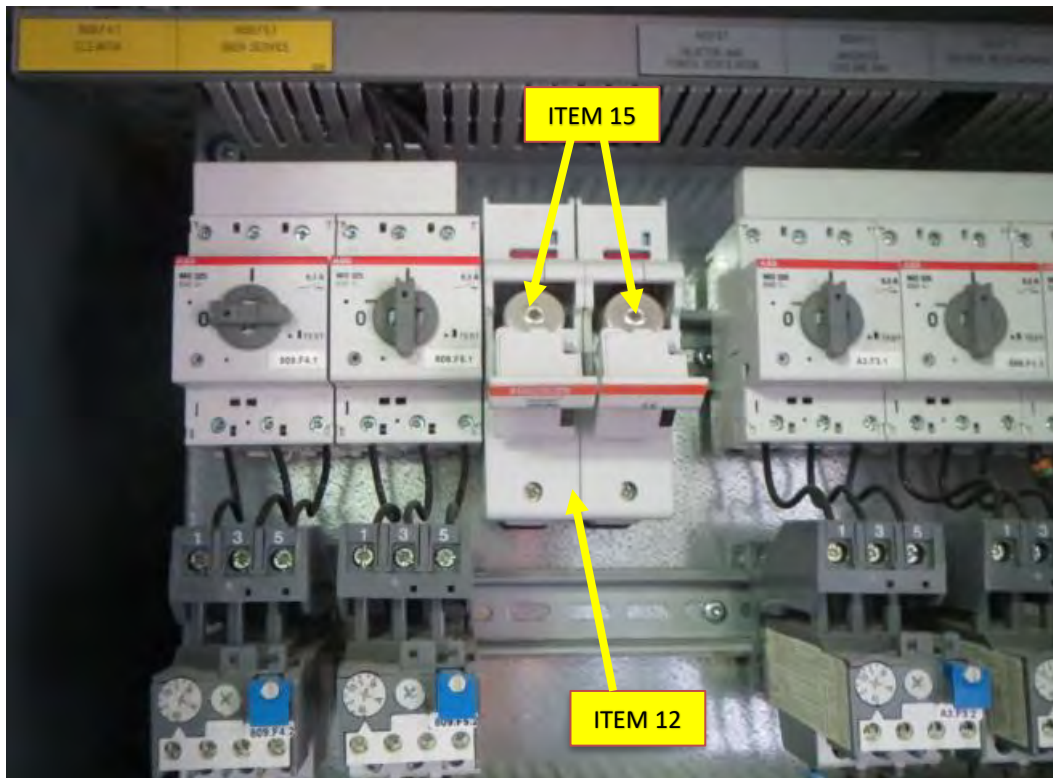

23. Install 175V Terminal Block and Fuse Holder

- Using a spare length of DIN-rail in cabinet section A1, install the Fuse Holder, Fuse, and terminal block components as shown:

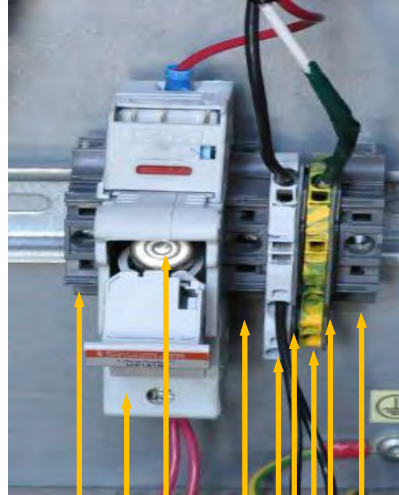

- End Stop (*Item 20*)
- Fuse Holder (*Item 13*)
- Fuse (*Item 14*)
- End Stop (*Item 20*)
- Feedthrough Terminal (*Item 17*)
- End Section Cover (*Item 19*)
- Ground Terminal (*Item 28*)
- End Section Cover (*Item 19*)
- End Stop (*Item 20*)

24. Install Auxiliary-Power Wiring

- The following schematic shows the wiring of auxiliary-power:

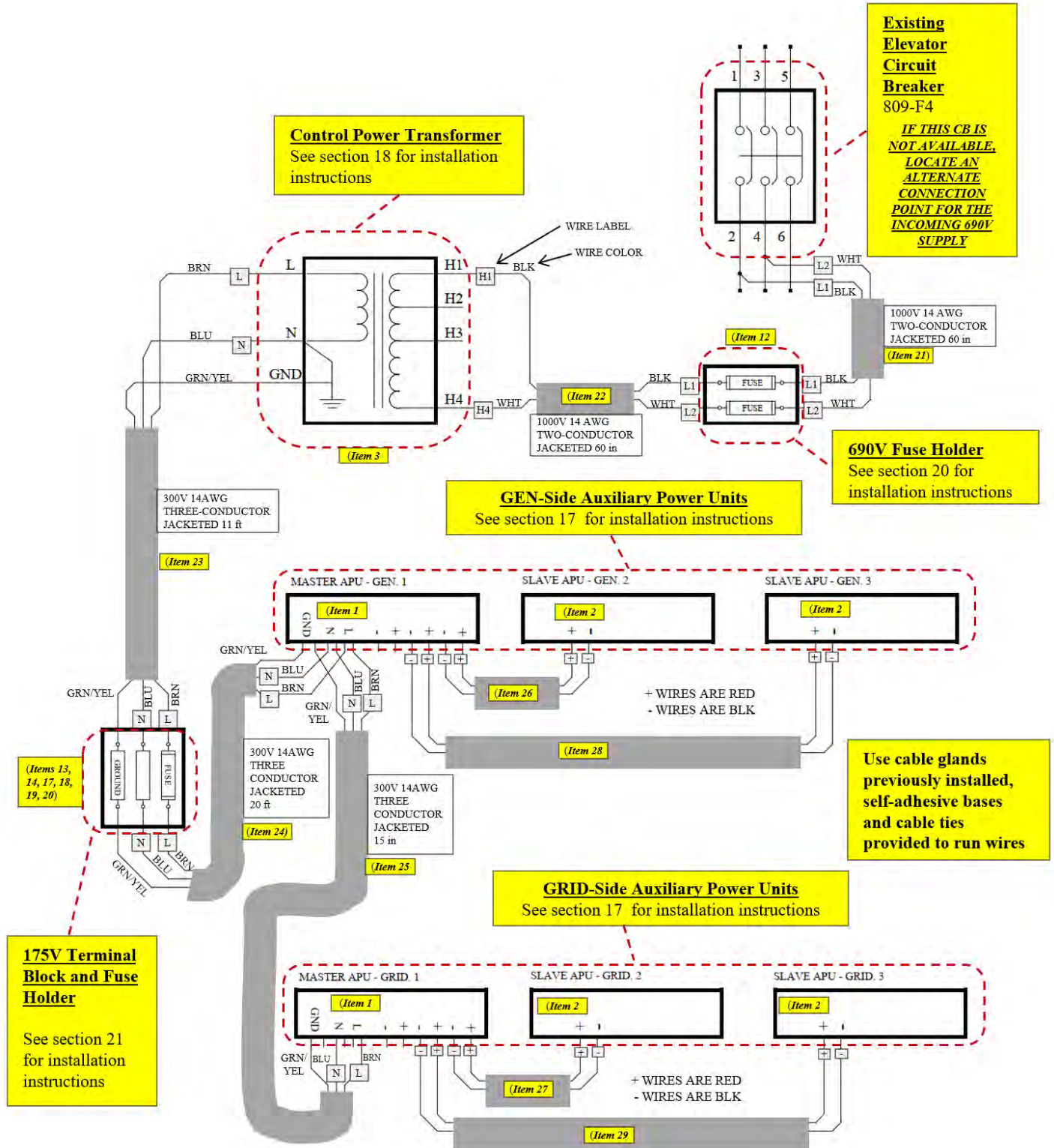

25. Install Ground Brackets and Ribbon Cables

- Install the offset ground brackets (**Items 6**) to allow the ribbon cables to route from the A12-1 & A12-2 cubicles into the control cabinet using original M4 x 6 screws.

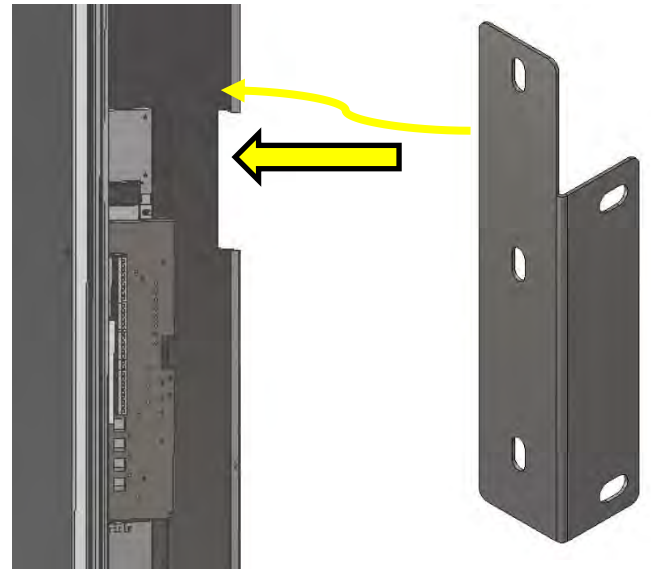

ITEM 6 – GRID SIDE



M4x6 TAPTITE

ITEM 6 – GRID SIDE FITTED

- Route the ribbon cables as shown below.

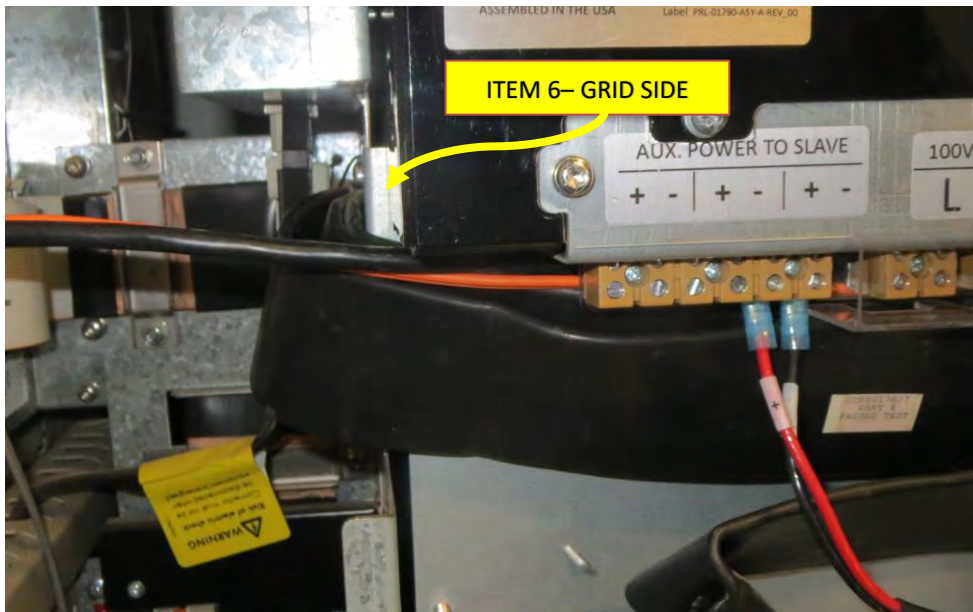

- Connect and clamp down all ribbon cables to each AEI unit and tie wrap into place:

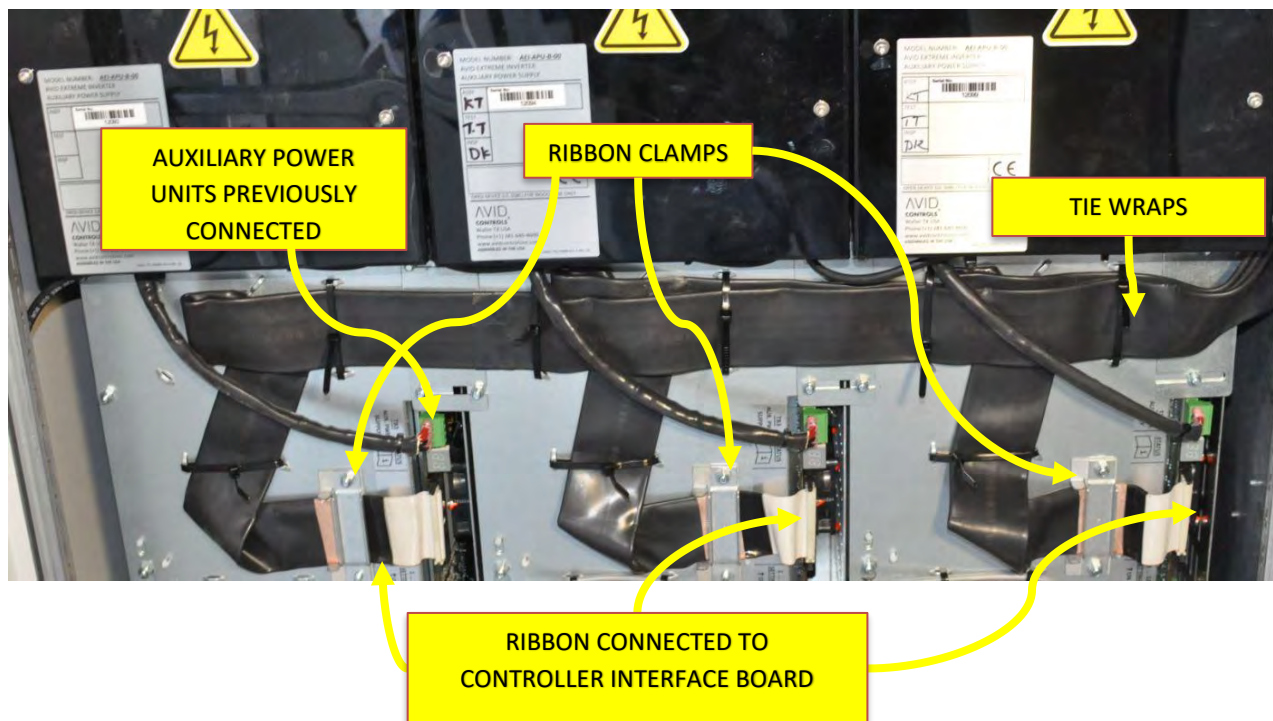

26. CDC IO Board Power Modification

Background

- When operating with original MVDL800 units, the CDC controllers are powered by the auxiliary 24V supply before the main DC link is energized (hence the Delta modules are not powered).
- This must be changed to power the CDC always from the AEI900L/AEI1000L units. Since the AEI's are always powered when the main 690V incoming supply is connected, there is no need for an auxiliary supply to the CDCs.

Procedure – This Must be Done on Generator and Network I/O Boards

- Locate the CDC I/O boards and disconnect Red wire from TB1F(L) Pin 2.

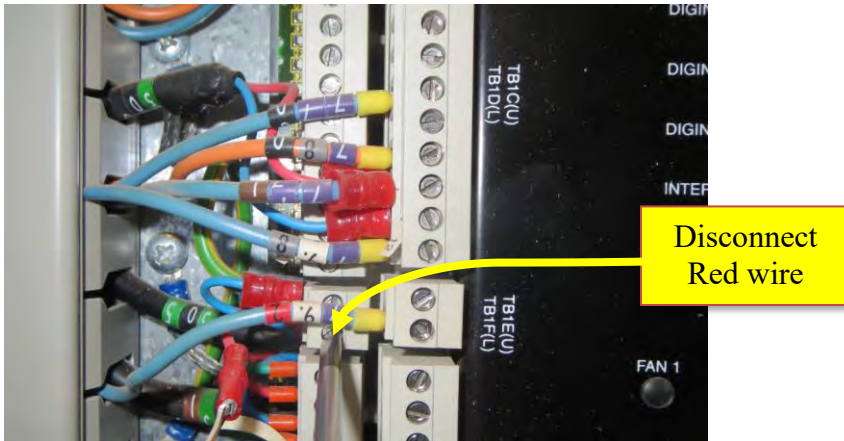

- To protect the exposed termination on the disconnected wire, fit the splicing connector (Item 34) and label as shown.

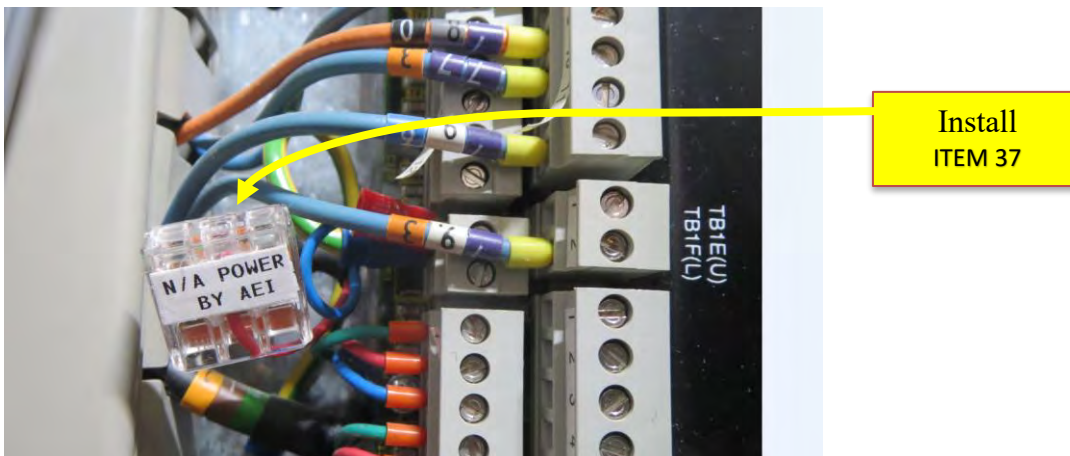

27. Reinstall Lower Cubicle Shrouds

- Referring to the figures below, reinstall the polycarbonate lower cubicle shrouds into the A12-1 and A12-2 inverter cubicles:
- **DEPENDING ON THE EXACT CABINET CONSTRUCTION, IT MAY BE NECESSARY TO REMOVE (BY CUTTING) CERTAIN FLANGES ON THE SHROUDS TO AVOID INTERFERENCE WITH THE AEI OR APU MODULES.**
- **IT MAY ALSO BE NECESSARY TO REMOVE THE PLUGGABLE TERMINAL BLOCKS TB4, TB5 & TB6 FROM THE AEI MODULES. IF THE FUNCTIONALITY PROVIDED VIA THESE TB'S IS REQUIRED, PLEASE CONTACT AVID FOR SUPPLY OF REPLACEMENT SHROUDS.**

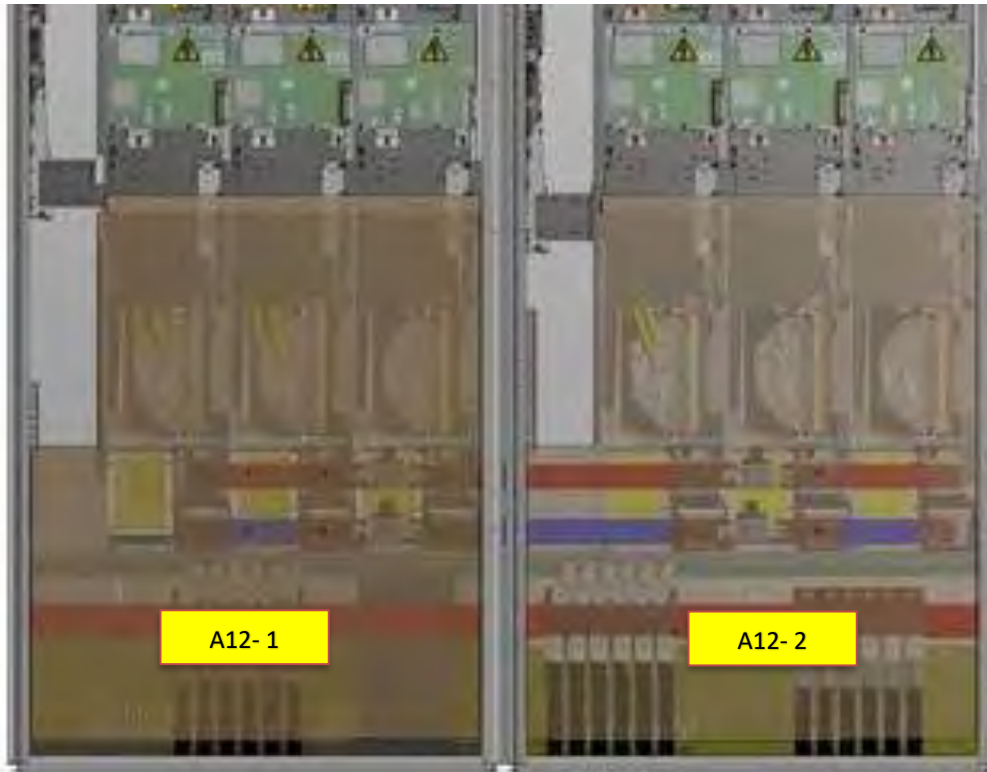

28. Reinstall Upper Cubicle Shrouds

- Referring to the figures below, reinstall the polycarbonate upper cubicle shrouds into the A12-1 and A12-2 inverter cubicles:

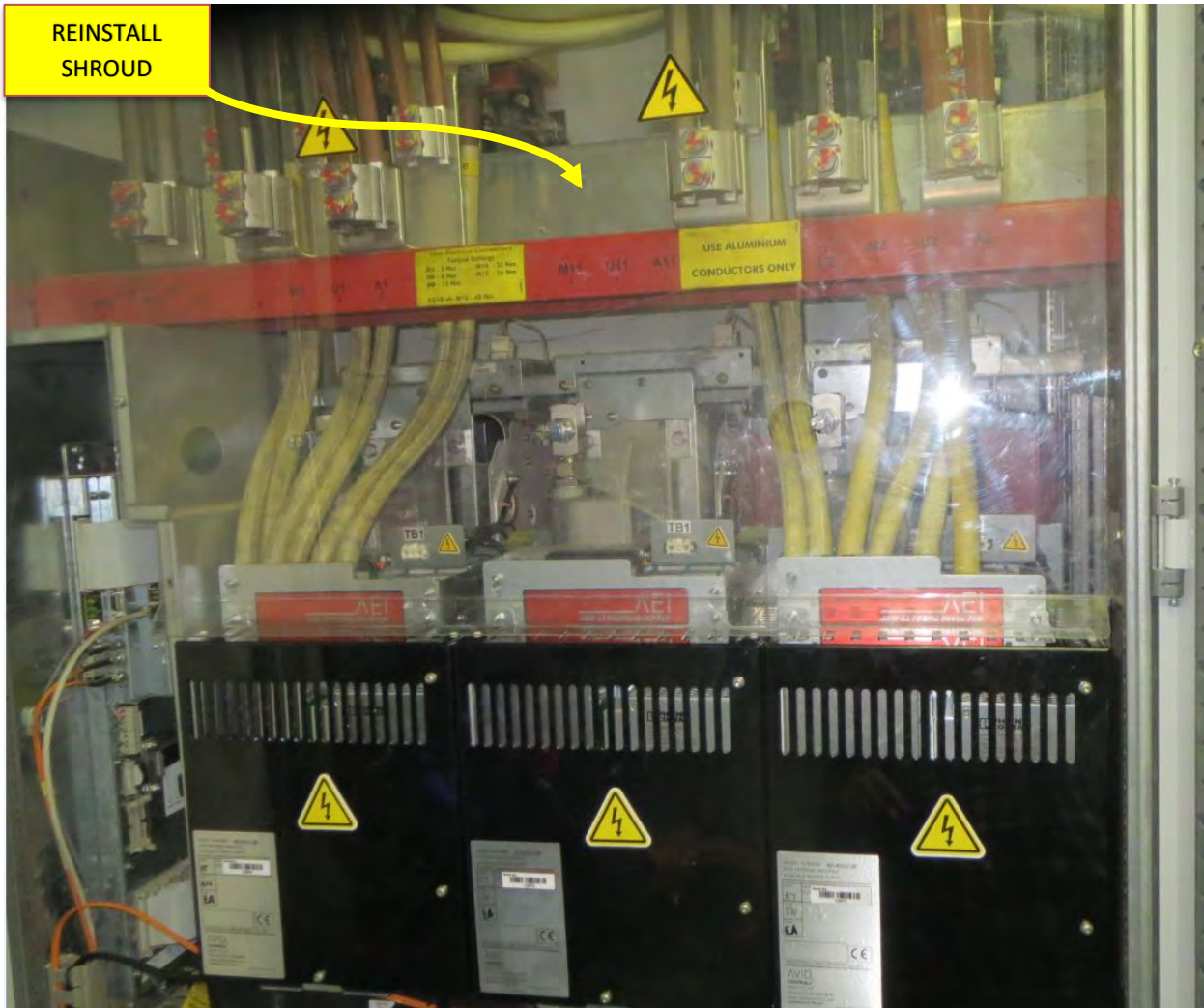

29. Install Fuse and Breaker Labels

- Install "**CONVERTER CONTROL POWER**" labels close to the 690V and 175V fuse holders in cubicle A1:



- Install "**CAUTION: EXTERNAL CONTROL VOLTAGE PRESENT WITH MAIN CIRCUIT BREAKER TURNED OFF**" labels on the doors of the A12-1 and A12-2 converter cubicles:

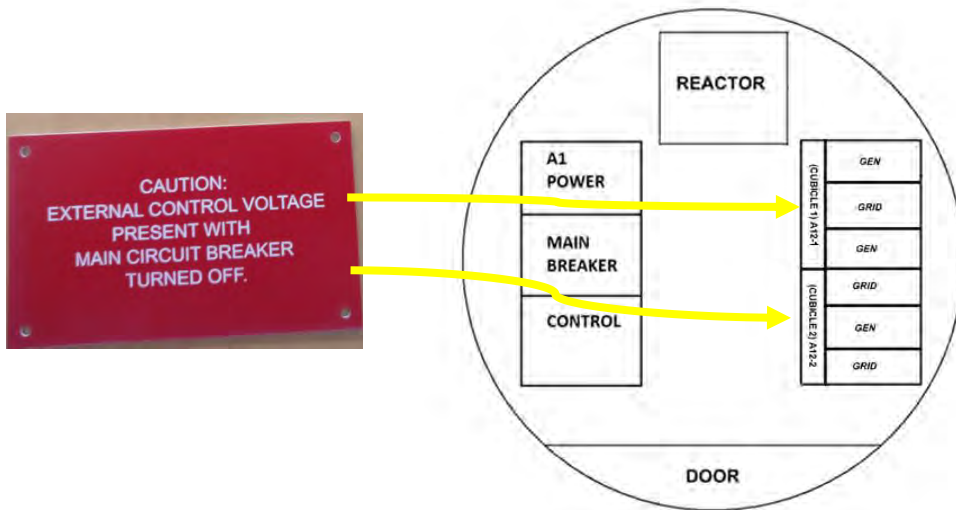

30. Turbine Restart

Background

- When operating with original MVDL800 units, the CDC controllers are powered by the auxiliary 24V supply before the main DC link is energized (hence the Delta modules are not powered). This means that the CDC cannot identify the Delta modules, leading to faults that interfere with the Siemens control system. To avoid these faults, P10.36 instructs the CDC not to read data from the Deltas, but to remember the previously identified values.
- This must be changed to allow the CDC to read data from the AEI900L/AEI1000L units. Since the AEI's are always powered when the main 690V incoming supply is connected, there is no need for an auxiliary supply to the CDC's and the AEI module data should ALWAYS be read by the CDC.
- It is also necessary to set the active-sharing parameters for the AEI drives to their default values in case they have been changed for the Delta system.
- ***This procedure will need to be repeated if either the GRID or GENERATOR CDC is replaced at a future date.***

Procedure

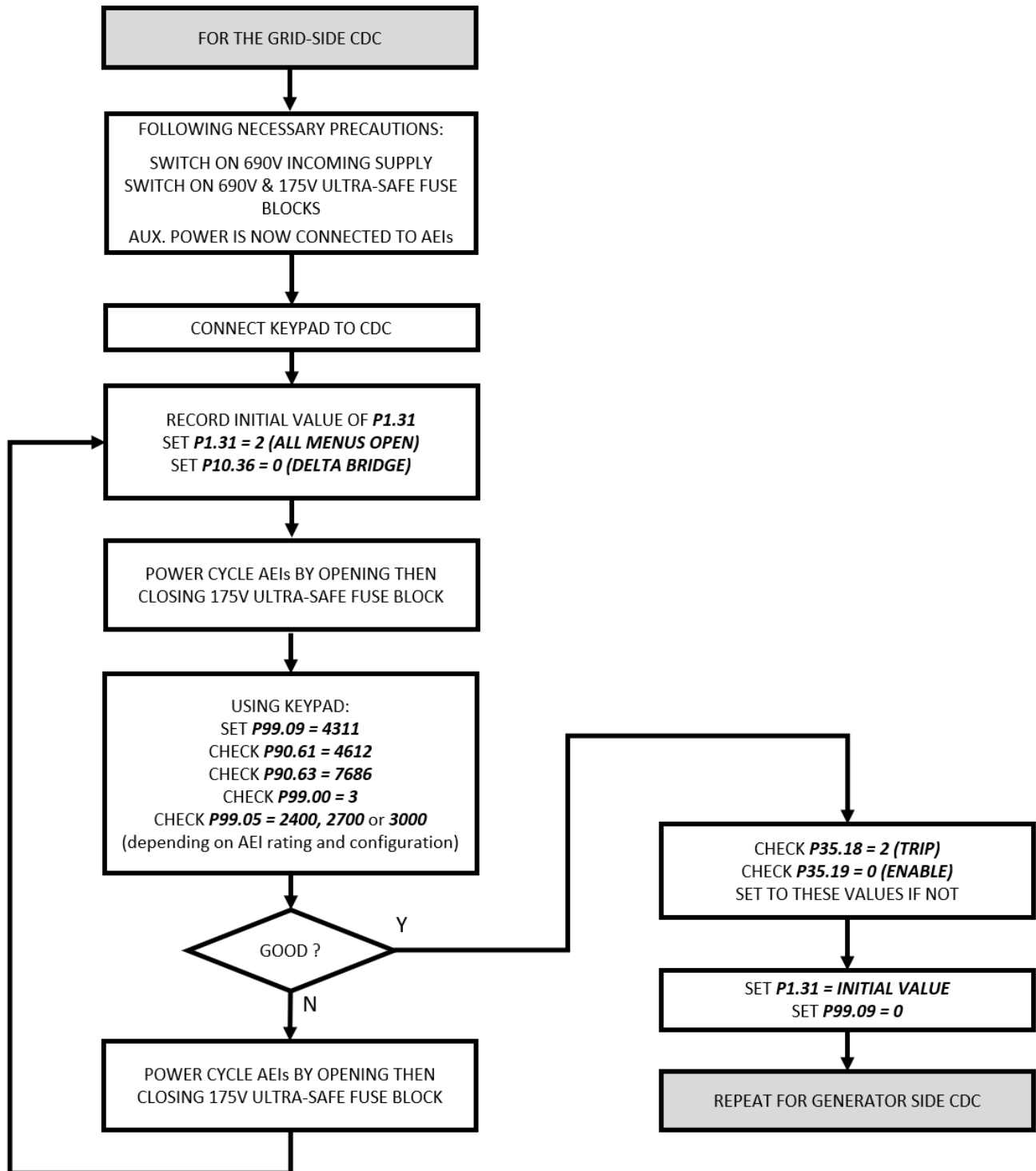

31. Label CDCs

- If at any time a CDC module needs to be replaced with either a brand-new unit, or one that has previously operated with Delta modules, ***IT IS CRITICAL THAT THE ABOVE PROCEDURE IS FOLLOWED FOR THE REPLACEMENT CDC.***
- To help ensure this happens the upgrade kit includes several copies of this label:



- Which should be attached to BOTH CDCs as shown:

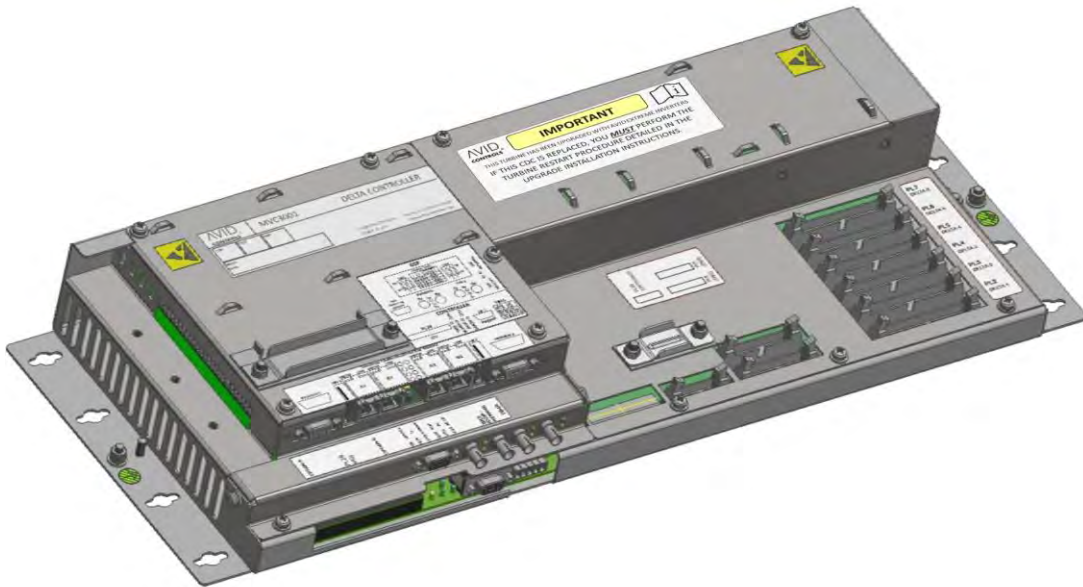

- **Also, temporarily remove the CDCs and attach another copy of this label to the cabinet back-panel underneath the CDC so that it will be visible whenever the CDC is removed.**
- A total of eight copies of this label are provided in the upgrade kit (peelable from a single sheet). Place the sheet with the spare labels into the magnetic envelope provided so that they are available if the CDCs are replaced in the future.

32. Attach Documents for Reference

- Locate the magnetic clear plastic envelope supplied with the upgrade kit.
- Place one copy of the following documents inside:
 - DTS-01894-ASY-A - This Data Sheet
 - DTS-MID0012 - Avid Extreme Inverter Data Sheet
 - DTS-MID0124 - Auxiliary Power Unit – Types D/E/F data Sheet
 - PRL-MID0169 - CDC Warning Label (spare copies)
- Attach the envelope to the inside of the control cabinet door:



33. Fit the Upgrade Identification Label

- The upgrade kit includes two weather-proof self-adhesive labels (Item 5) that may be applied to the turbine to clearly indicate that it has been upgraded with Avid Extreme Inverters:

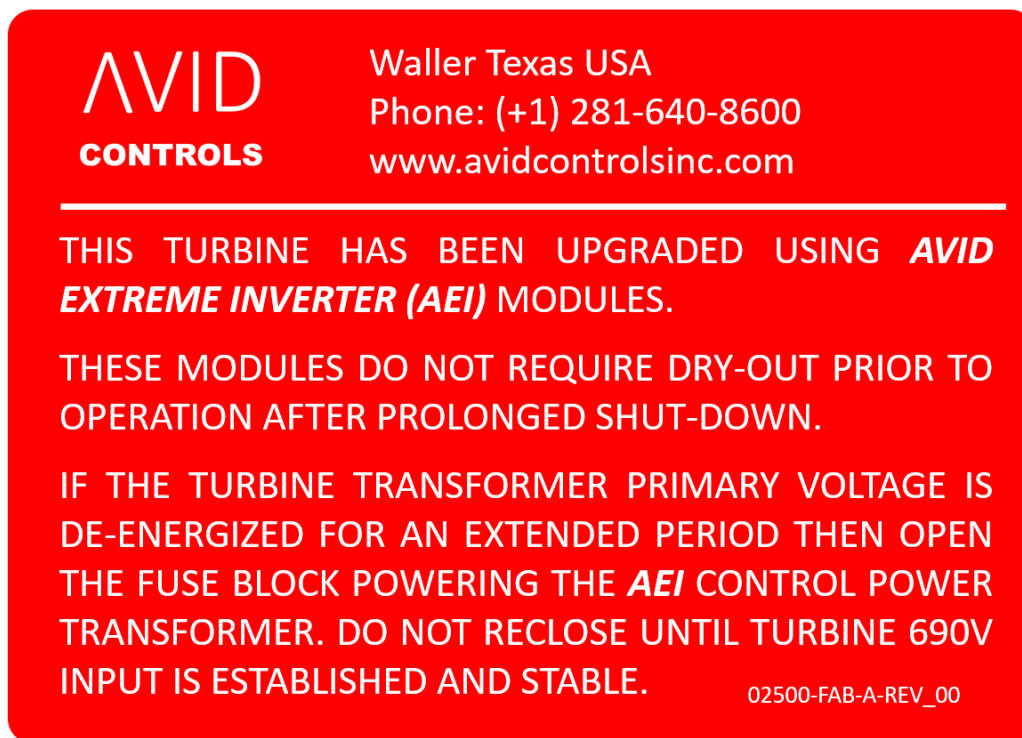

- These may be applied on the interior or exterior of the turbine as-per customer preference (e.g. on the turbine door).
- Surface preparation wipes are also included in the kit.

34. Notes for Operation and Maintenance of Upgraded Turbine

CDC Replacement

- If either CDC is replaced, it is ***essential*** to repeat the procedures detailed in sections 30 and 31 of this Data Sheet.
- This includes labelling the new CDC using one of the spares stored in the document envelope.
- It is also recommended to apply another copy of this label onto the cabinet wall underneath the CDC.

Reconnection of Medium-Voltage Distribution Supply

Background

- This requirement applies to turbines upgraded using the CPT and AEI-APU-E/F option.
- When the medium-voltage supply to the turbine pad transformer is reconnected after being disconnected at the sub-station, there is a possibility that line resonance can cause a transient over-voltage on the 690V supply to the turbine.
- This is not seen by equipment connected to the load side of the main breaker (which is open), but the AEI CPT is connected to the incoming side, and these transient over-voltages can damage both the APU and AEI modules.

Procedure

- When the medium-voltage distribution supply is powered down, you must disconnect the AEI CPT from the turbine 690V supply, prior to re-energizing the distribution voltage.
- This can be achieved by opening the breaker that was used to supply the CPT (usually the elevator circuit breaker), or by opening the ultra-safe fuse block that was installed with the upgrade.
- After the medium-voltage distribution supply is reconnected and stable, the CPT should be reconnected, and the turbine will start as normal.

35. Document Revision History

Rev.	Date	Author	Changes
00	Feb 25, 2021	O. Guerra	Document created
01	Mar 16 2021	G. Pace	Avid-supplied tools detailed
02	Aug 2 2021	G. Pace	5-minute warning changed to 8-minutes
03	Oct 22 2021	G. Pace	Hose-clamp torque changed to 4 Nm
04	Nov 17 2021	G. Pace	Restart flowchart revised AEI900L or AEI1000L allowed CDC label added Polycarbonate shrouds to be re-used Upgrade identification label added Tighten manifold hose clamps before fitting AEIs
05	Feb 2 2022	G. Pace	Clearly identified as using APUs E & F Correct AEI900L & AEI1000L modules are now listed - plumbing option A
06	Mar 24 2022	G. Pace	M10 electrical connection torques changed to 35Nm
07	April 12, 2022	Z. Gordon	Grounding bracket and assocoied cabinet modification detailed
08	April 25, 2022	Z. Gordon	Added inner cubicle bonding bracket replacement instructions. Added miscellaneous items to Parts List
09	July 29, 2022	G.Pace	Installation check-list added Tool to release/insert spring clamped wires listed
10	March 30, 2023	G.Pace	Recommendation to change DC fuses added
11	Dec 12 2023	G. Pace	Added instruction to place label on cabinet back-panel behind the CDCs

36. Appendix A – Optional Contactor for AEI Auxiliary Power Switching

- If it is required to interrupt the auxiliary supply to the AEI modules under control of the turbine control system (for example, to run a Siemens turbine calibration), this can be achieved by the addition of a suitable contactor in the 175Vac supply to the Auxiliary Power Units

Additional Parts

Item Reference	Qty.	Description
A1	1	Contactor, NEMA, 3 Pole, 17A, 230-240VAC@60Hz, 220-230VAC@50Hz Coil, DIN/Panel Mount. Manufacturer: ABB, Part Number: A16-30-10-80
A2	1	Suppressor; Varistor; 110-250VAC/VDC; For A9-A110/AE9-AE110/AL9-AL40 Contactor. Manufacturer: ABB, Part Number RV5/250
A3	1	Cable assembly, 20-ft, 2-conductor, 300Vac 2.5mm ² , black outer jacket For connection from A1 Contactor coil and existing 809.X7 position #2 and #3
A4	1	Cable assembly, 1-ft, 1-conductor, 300Vac 2.5mm ² , brown For connection from 175V fuse holder and new contactor A1

Changes to Auxiliary-Power Wiring

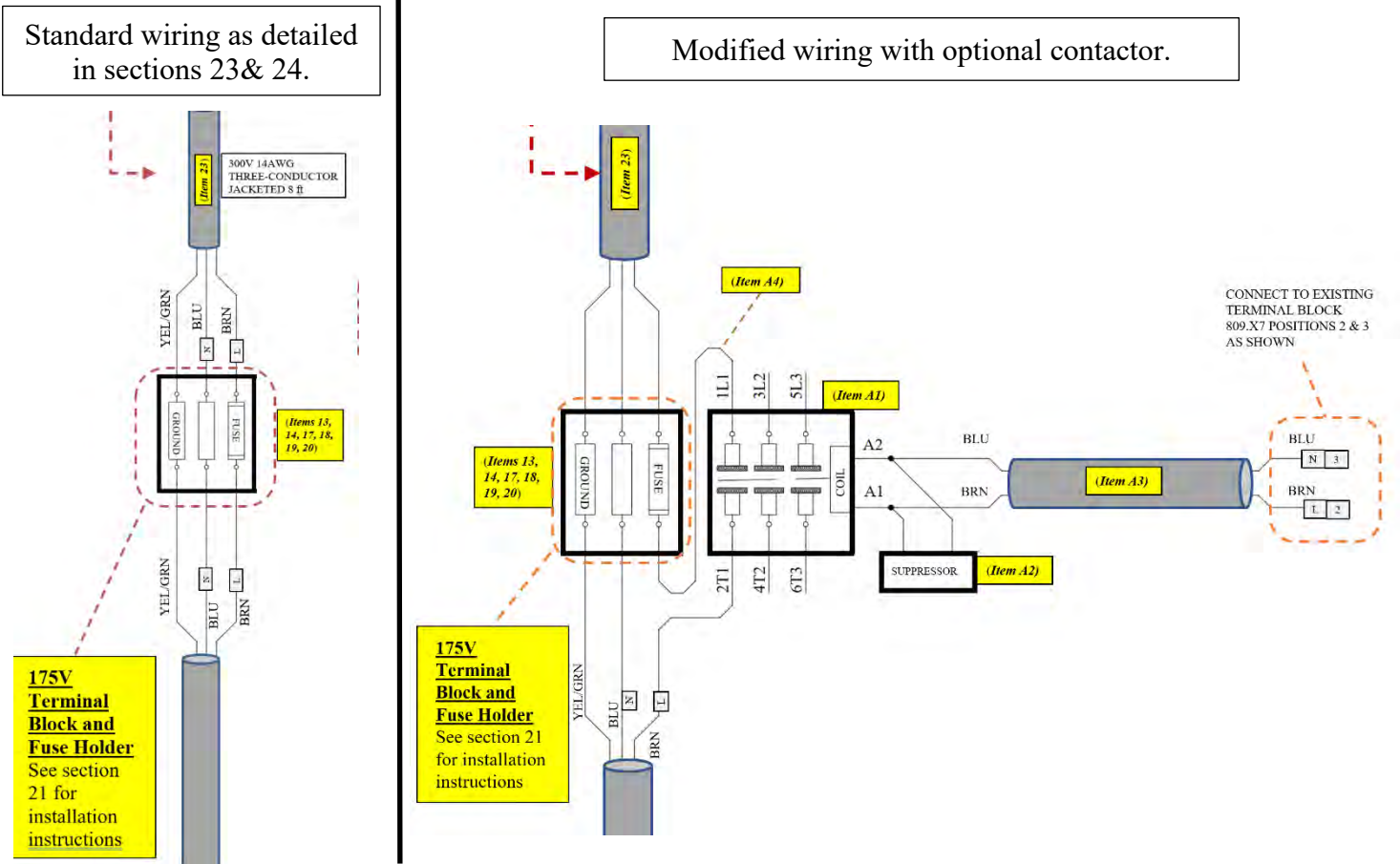

Suggested Sequence to Install Optional Contactor After Standard Upgrade

1. Remove all power from the cabinet.
2. Connect suppressor **[Item A2]** to contactor **[Item A1]**.
3. Using a spare length of DIN-rail in cabinet section A21-R, install the contactor **[Item A1]**.
4. Disconnect bottom live wires from previously installed fuse block **[Item 13]**.
5. Connect these wires contactor **[Item A1]** terminal 2T1.
6. Use the new wire **[Item A4]** to connect the previously disconnected fuse block **[Item 13]** to the new contactor **[Item A1]** terminal 1L1.
7. Located **809.X7** terminal block positions **2 and 3** in A21R Cubicle.
8. Connect new two-core cable **[Item A3]** brown wire to 809.X7 position 2.
9. Connect new two-core cable **[Item A3]** blue wire to 809.X7 position 3.
10. Connect new two-core cable **[Item A3]** brown wire to new contactor **[Item A1]** terminal A1.
11. Connect new two-core cable **[Item A3]** blue wire to new contactor **[Item A1]** terminal A2.

37. Appendix B – Installation Checklist

Before Going to Turbine

CUSTOMER:		SITE NAME:	
TURBINE NUMBER:		AVID TECHNICIAN (or N/A):	
CUSTOMER LEAD TECHNICIAN:		DATE:	

All Tools Available:

Item	Initial	Item	Initial	Item	Initial
MV3000 Keypad with Cable		Diagonal wire cutters		Wire strippers/cutters	
Torx T25 Driver		Phillips #2 x 4” Screwdriver		3/16” x 4” Slotted Screwdriver	
#3 Pozi-drive Screwdriver		Socket Wrench, 3/8” Drive		Torque Wrench, 3/8” Drive	
5mm Socket, 3/8” Drive		8mm Socket, 3/8” Drive		10mm Socket, 3/8” Drive	
17mm Socket, 3/8” Drive		Socket Extension 10” Long, 3/8” Drive		Adjustable Crescent Wrench, 1” Jaw Capacity	
Power Impact Tools		Power Drill		¼” Hex to ¼” Drive Socket Adapter [*1]	
8mm ¼” Drive Socket [*1]		10” ¼” Drive Extension [*1]		4 NM Torque Key [*1]	
Hydrometer Kit		Digital Voltmeter (DVM)		Torque Seal [*1]	
AEI/Delta Lift Hoist (if available)		AEI/Delta Installation Dolly (if available)		6ft Ladder (if required)	
8mm crescent wrench		Laptop with Drive Coach and RS232		Suitable tool (screwdriver) for wire release/insertion on spring clamp terminals	

[*1] : These tools are provided as part of the AEI upgrade kit

AEI Upgrade Kit Complete

Refer to the upgrade kit parts list is section 5 of this Data Sheet.

UPGRADE KIT SERIAL NUMBER: _____

Item	Initials
All items in parts list correctly received	

Item	Initials
All documents in document list correctly received	

Turbine History

Was turbine in running condition before AEI upgrade?: _____

If turbine was not in running condition, please attach all available fault history (from SCADA or Drive Coach) and describe all known details of the fault / problem.

Description of attachments:

At Turbine, Before Removing Deltas

CUSTOMER:		SITE NAME:	
TURBINE NUMBER:		AVID TECHNICIAN (or N/A):	
CUSTOMER LEAD TECHNICIAN:		DATE:	

Status of Turbine:

Turbine Faults (if applicable)
(blown fuses, tripped breakers, system fault codes etc.):

Visible Damage (Before Removing Deltas)
(Damaged cables or ribbons, missing hardware, coolant leaks etc.) :

Check coolant with hydrometer and record result
If out of specification, coolant must be replaced before installation of AEI units:

Hydrometer Reading: _____ Units: _____ In Spec ? : _____

Customer Lock-out Tag-Out Procedures complete: _____ System safe voltage checks AC & DC complete: _____

Position of all cables, ribbons, tie-wraps etc. recorded: _____

Identify and record GEN side master SMPS jumper settings (jumper 10-13) and record below:

Jumper 10: _____ Jumper 11: _____ Jumper 12: _____ Jumper 13: _____

Identify and record GRID side master SMPS jumper settings (jumper 10-13) and record below:

Jumper 10: _____ Jumper 11: _____ Jumper 12: _____ Jumper 13: _____

After Installation, Before Power-On

CUSTOMER:		SITE NAME:	
TURBINE NUMBER:		AVID TECHNICIAN (or N/A):	
CUSTOMER LEAD TECHNICIAN:		DATE:	

CHECK ITEM	Grid Position 1	Grid Position 2	Grid Position 3	Gen Position 1	Gen Position 2	Gen Position 3
AEI Serial #						
APU Serial #						
DIP Switches ON (circle those that are ON)	1 2 3 4 5 6 7 8 9 10 11 12	1 2 3 4 5 6 7 8 9 10 11 12	1 2 3 4 5 6 7 8 9 10 11 12	1 2 3 4 5 6 7 8 9 10 11 12	1 2 3 4 5 6 7 8 9 10 11 12	1 2 3 4 5 6 7 8 9 10 11 12
Power Terminal Torque set to 35Nm and sealed	Aph #1					
	Aph #2					
	Bph #1					
	Bph #2					
	Cph #1					
	Cph #2					
	DC+ #1					
	DC+ #2					
	DC- #1					
	DC- #2					
Pull-test control wires						
DC fuses replaced						
Ribbon clamps secure and not damaging insulation						
Coolant hoses torqued to 4 Nm using torque- key						
All wires/cables correctly tie-wrapped						

Turbine Restart Checklist

CUSTOMER:		SITE NAME:	
TURBINE NUMBER:		AVID TECHNICIAN (or N/A):	
CUSTOMER LEAD TECHNICIAN:		DATE:	

All air purged from cooling system: _____ No coolant leaks detected: _____

Check and record the final values of the following parameters etc. for both GEN and GRID CDC:

Parameter Etc.	Expected Value	GEN Value	GRID Value	Notes
P99.00	3			
P99.05	2400, 2700 or 3000			Depends on AEI type and setting
P10.36	0			
P35.18	1			
P99.09	0			Return to zero <i>after</i> restart procedure
P1.32	Customer Preference			Return to its original value <i>after</i> restart procedure
CDC Part Number				
CDC LED Shape	Round or Square [R/S]			
CDC Firmware Version				
Parameter Set File				



Avid Extreme Inverter – Turbine Upgrade Installation Instructions, APU E/F, SWP Type 27

List and Describe any Faults During Re-Start:

Confirm document envelope and all contents (see section 32) installed in cabinet: _____

Record the 2-digit display readouts on each AEI:

GEN #1: _____ GEN #2: _____
GEN #3: _____ GRID #1: _____
GRID #2: _____ GRID #3: _____

Additional Information:
