

REV: 06

February 13th 2024

Avid Controls Inc.
41261 Park 290 Drive, Waller, TX 77484, USA
info@avidcontrolsinc.com
(+1) (281) 640-8600

**THIS DATA SHEET CONTAINS AN INSTALLATION CHECKLIST THAT MUST BE
COMPLETED AND RETURNED TO INFO@AVIDCONTROLSINC.COM
SEE APPENDIX A**

AVID Controls Inc. pursues a policy of continuous product improvement and innovation. This may not be the latest revision of this publication and may not reflect all current product changes. Contact AVID Controls Inc. for the latest revision of this data sheet and information on other product enhancements.



Avid Extreme Inverter – Turbine Upgrade Installation Instructions, SWP 3.6MW, APU-G

INTENTIONALLY BLANK

AVID CONTROLS and the  logo are registered trademarks of Avid Controls Inc.

Contents

1.	Introduction	5
2.	WARNINGS	5
3.	Tools and Supplies Required.....	6
4.	Necessary Avid Supplied Bill of Materials.....	7
5.	Optional GRID DC Fishplate and Generator Fan Upgrade Kits.....	7
6.	DC Fuses for Inter-Module Connection.....	7
7.	Grid Upgrade Kit Parts List (AEI-UPGR-KIT-06).....	8
8.	Generator Upgrade Parts List (AEI-UPGR-KIT-05)	9
9.	Overview of SWP 3.6MW Cabinet Layout.....	10
9.1	Tower Base Layout.....	10
9.2	Prior to Removal of MVDL1000 DELTA Modules.....	12
9.3	Record jumper settings	13
9.4	Remove Cabinet Shrouds - GRID	14
9.5	Remove SMPS & Ribbons from MVDL1000 DELTA Modules.....	15
9.6	Disconnect MVDL1000 DELTA Modules	16
9.7	Remove covers to access coolant pipes.	17
9.8	Remove Grid MVDL1000 DELTA Modules, Replace Hoses	18
10.	Modify Side Panel.....	19
11.	Install AEI1000L Modules Grid Cabinet	20
11.1	Set AEI DIP Switches	20
11.2	Prepare 4 x AEI1000L Modules for Installation into Grid Cabinet.....	21
11.3	Install 4 AEI1000L Modules into the GRID Cabinet.	22
12.	Connect Coolant Hoses	23
13.	Reconnect DC Cables.....	24
14.	Reinstall Grid Cubicle AC Cables.....	25
15.	Install Ground Bonding Brackets and Ribbon Cables.....	26
16.	Install Auxiliary Power Units, Grid Cabinet.....	27
17.	Optional Connection of Auxiliary 24VDC Supply to APUs	28
18.	Modify GRID Shroud.....	29
19.	Refit Cubicle Shrouds	30
20.	Nacelle Layout	31
20.1	Prior to Removal of MVDL1000 DELTA Modules	33
20.2	Record jumper settings.....	34
20.3	Remove Cabinet Shrouds, GEN.....	35
20.4	Remove SMPS & Ribbons from MVDL1000 DELTA Modules	36
20.5	Disconnect MVDL1000 DELTA Modules.....	37
20.6	Remove covers to access coolant pipes.	38
20.7	Remove MVDL1000 DELTA Modules, Replace Hoses, Gen	39
21.	Install AEI1000L Modules Gen Cabinet.....	40
21.1	Set AEI DIP Switches	40

21.2	Install 4 x AEI1000L Modules into Generator Cabinet.....	41
22.	Connect Coolant Hoses	42
23.	Reinstall Generator Cubicle AC & DC Cables	44
23.1	Reinstall AEI Cover Plates	45
24.	Install Ground Brackets and Ribbon Cables	46
25.	Install Auxiliary Power Units, Generator Cabinet	48
26.	Modify GEN Middle Shroud.....	50
27.	Install cubicle shrouds	51
28.	Label CDC’s – Grid & Gen.....	52
29.	Attach Documents for Reference	53
30.	Fit the Upgrade Identification Label	54
31.	Restart Turbine	56
31.1	Set CDC Parameter P10.36.....	56
31.1.1	Background	56
31.1.2	Flowchart.....	57
32.	Document Revision History	58
33.	Appendix A – Installation Checklist	59

1. Introduction

- The following procedures are specific to the installation of the AVID AEI1000L liquid-cooled inverter module.
- These procedures detail how to upgrade a Siemens Wind Power 3.6MW turbine from Original Delta modules to AEI (Avid Extreme Inverter) modules and associated installation kit.
- For reference, see the following AVID documents which are supplied alongside this Installation Instruction:
 - DTS-MID0012 for additional specifications related specifically to the AEI1000L.
 - DTS-02175-ASY-A for additional specifications related to the Auxiliary Power Units

2. WARNINGS

- Always refer to the Cautions and Warnings in the associated MV DELTA and MV3000 manuals when installing / commissioning / fault-finding any system containing an AEI1000L module.
- This equipment may be connected to more than one live circuit.
- **Disconnect all power sources before working on the equipment.**
- **Wait at least 8 minutes after isolating all power sources and check that the voltage between DC+ and DC- has reduced to a safe level before working on the equipment.**
- Surfaces on the coolant pipes can reach high temperatures and remain hot for some time after power is switched off.
- Ensure that all coolant has cooled to a safe temperature, and the equipment is suitably drained and isolated before disconnected the external pipework from the equipment.
- Figures are for reference only.
- Appendix A contains an installation checklist for the turbine upgrade. This must be completed and returned to info@avidcontrolsinc.com to activate the individual product warranties for the Avid equipment.

Each field in the checklist requires either initials, the recording of specific information (such as parameter values) or “N/A” if not applicable

- It is recommended that all DC fuses are replaced during this upgrade – see section 6.

3. Tools and Supplies Required

Wire Cutters	10mm Socket, 3/8” Drive
TORX T25 Driver	17mm Socket, 3/8” Drive
Phillips #2 x 4” Screwdriver	Power Impact Tools (DeWalt or similar)
3/16" x 4" Slotted Screwdriver	4.5mm Drill
#3 Pozi-drive Screwdriver	Hydrometer kit
1/2” Drill bit	8mm Crescent Wrench

8mm Socket, 3/8” Drive

MV3000 Keypad with cable

5/16” Drill bit

Digital Voltmeter (DVM)

Adjustable Crescent Wrench, 1” Jaw Capacity

Suitable tool (screwdriver) for wire release/insertion on spring clamp terminals

AEI/Delta installation lift table (if needed and available – contact Avid for more details)

Small Hacksaw

Half-Round File

Required Tools Supplied by Avid

Sheetmetal / Lexan cutting tool (Dicfeos REX003
Double Head Sheet Nibbler or similar)
4Nm Torque Handle
Drive Socket Extension 10” Long, 1/4” Drive
1/4” square standard drive socket, Chrome, 8mm
Hex shank to 1/4” square drive adapter

4. Necessary Avid Supplied Bill of Materials

AVID Model Number	Qty.	Description
AEI1000L-412103-00-[N]/[S]	8	Avid Extreme Inverter, 1000A 690V, Plumbing Option B, without capacitor fans, Special Option 3*, [N]=New, [S]=Enhanced Reman.
AEI-UPGR-KIT-05	1	AEI1000L Upgrade Kit. For SWP 3.6MW Turbines. NO CPT. Generator Converter.
AEI-UPGR-KIT-06	1	AEI1000L Upgrade Kit. For SWP 3.6MW Turbines. NO CPT. Grid Converter.

***Special Option 3** indicates the fitting of:

- Additional DC Connections (Fish Plates, See below)
- DC Transient Voltage Suppressor
- Enhanced Vibration Mitigation

Note: These options may be required for enhanced AEI warranty

5. Optional GRID DC Fishplate and Generator Fan Upgrade Kits

AVID Model Number	Qty.	Description
AEC-UPGR-KIT-01	1	Assy, Wind Turbine Upgrade kit, Avid Extreme cable connection for 3.6MW Class Turbines. Grid Converter.
AEF-UPGR-KIT-01	1	Assy, Wind Turbine Upgrade kit, Avid Extreme cooling fans, set of 3 for 3.6MW Class Turbines. Generator Converter.

See separate product datasheets for installation instructions.

Note: These options may be required for enhanced AEI warranty.

6. DC Fuses for Inter-Module Connection

- All Siemens Wind Power (and Siemens Gamesa Renewable Energy) 2.3MW and 3.6MW turbines configure the Delta/AEI modules in hard-paralleled “sister” units, with relatively small rating DC fuses to interconnect the “sisters”.
- Experience has shown that these fuses age with time, and that faults in the Delta modules can accelerate this aging – often leading to premature failure.
- It is therefore strongly recommended that these fuses always be replaced when this upgrade is performed.
- Failure to do so may result in failure of the fuses shortly after re-starting the turbine.
- These fuses are standard spares for all wind sites, so are not provided as part of the upgrade kit.

7. Grid Upgrade Kit Parts List (AEI-UPGR-KIT-06)

Item Reference	Qty.	Description
1	4	Auxiliary Power Unit, Avid Model Number AEI-APU-G
2	1	Grounding Bracket, Grid side, 02384-FAB-A
3	4	Hose, Bottom barb of DELTA/AEI to inlet manifold, 183.5mm, 01811-CUS-A
4	4	Hose, Bottom barb of DELTA/AEI to outlet manifold, 275mm, 01812-CUS-A
5	16	Hose clamps, 01482-OTS-A
6	1	Bag, Document Envelope, Magnetic, Clear Plastic, 9" X 11.5"
7	1	Label, Upgraded Turbine Identification, AEI Upgrade, APU-G Turbines
8	1	Tool, T-Handle Wrench, Factory-Set Torque 4Nm 1/4" Drive, AEI Upgrade Toolkit
9	1	Tool, 1/4" Square Drive Socket Extension, Chrome, 10", AEI Upgrade Toolkit
10	1	Tool, 1/4" Standard Drive Socket Extension, Chrome, 8mm, AEI Upgrade Toolkit
11	1	Tool, Hex Shank to 1/4" Square Drive Socket Adapter, AEI Upgrade Toolkit
12	1	Tool, Double Headed Sheet Metal Cutting Nibbler, 360 Degree, Drill Attachment
13	1	Hardware, Tie-Wrap, 8-in, 18-lb, Black, Bag of 100
14	1	Hardware, Tie-Wrap, 11-in, 18-lb, Black, Bag of 100
15	1	Product Label, for CDC, Warning if DC is Replaced
16	1	6" Half-Round file
17	1	Small Hacksaw
18	1	Consumable Clean room wipes, 9" x 9", 70% IPA, Pack of 30
19	1	Chemical, Torque Marker, Permanent, Orange, 1 OZ Tube

8. Generator Upgrade Parts List (AEI-UPGR-KIT-05)

Item Reference	Qty.	Description
1	4	Auxiliary Power Unit, Avid Model Number AEI-APU-G
2	1	Grounding Bracket, Gen side, 02385-AFB-A
3	4	Hose, Bottom barb of DELTA/AEI to inlet manifold, 183.5mm, 01811-CUS-A
4	4	Hose, Bottom barb of DELTA/AEI to outlet manifold, 275mm, 01812-CUS-A
5	16	Hose clamps, 01482-OTS-A
6	1	Bag, Document Envelope, Magnetic, Clear Plastic, 9" X 11.5"
7	1	Label, Upgraded Turbine Identification, AEI Upgrade, APU-G Turbines
8	1	Product Label, for CDC, Warning if DC is Replaced
9	1	Tool, T-Handle Wrench, Factory-Set Torque 4Nm 1/4" Drive, AEI Upgrade Toolkit
10	1	Tool, 1/4" Square Drive Socket Extension, Chrome, 10", AEI Upgrade Toolkit
11	1	Tool, 1/4" Standard Drive Socket Extension, Chrome, 8mm, AEI Upgrade Toolkit
12	1	Tool, Hex Shank to 1/4" Square Drive Socket Adapter, AEI Upgrade Toolkit
13	1	Hardware, Tie-Wrap, 8-in, 18-lb, Black, Bag of 100
14	1	Hardware, Tie-Wrap, 11-in, 18-lb, Black, Bag of 100
15	1	Consumable Clean room wipes, 9" x 9", 70% IPA, Pack of 30
16	1	Chemical, Torque Marker, Permanent, Orange, 1 OZ Tube

9. Overview of SWP 3.6MW Cabinet Layout

9.1 Tower Base Layout

<i>Ref</i>	<i>Contains</i>
A14	Main Grid Filter Reactor
A1	Controller Box for grid supply and main circuit breakers
A2	Controller Box for UPS, hand terminal and computer
A11	Grid Filter
A12	Grid Frequency Power Converter

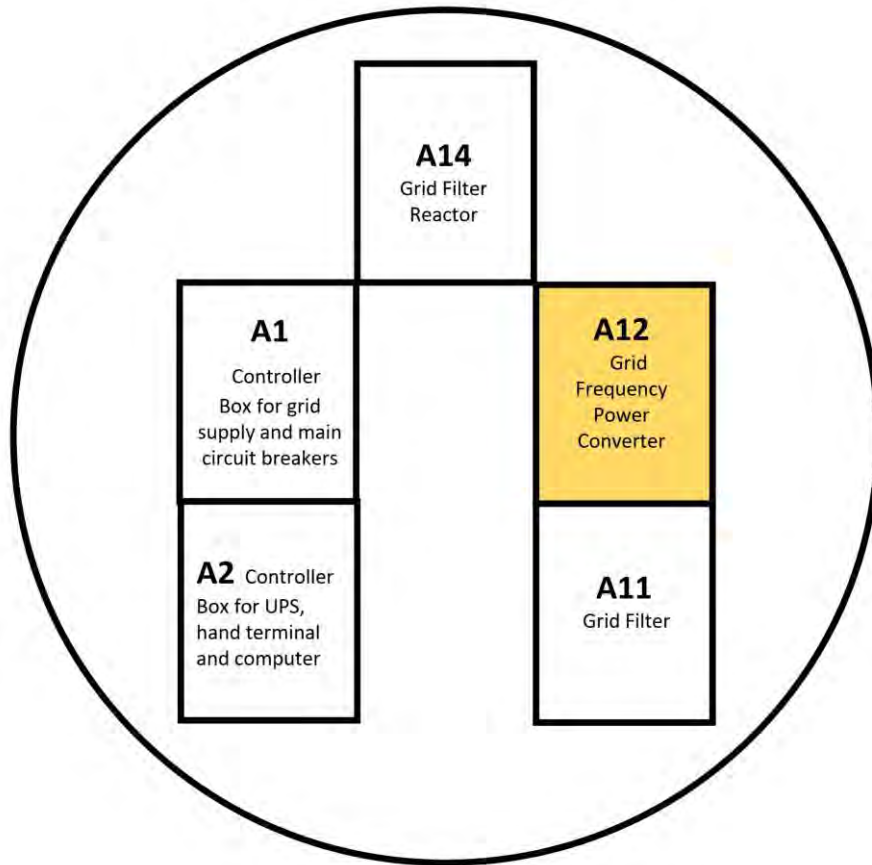

Plan View

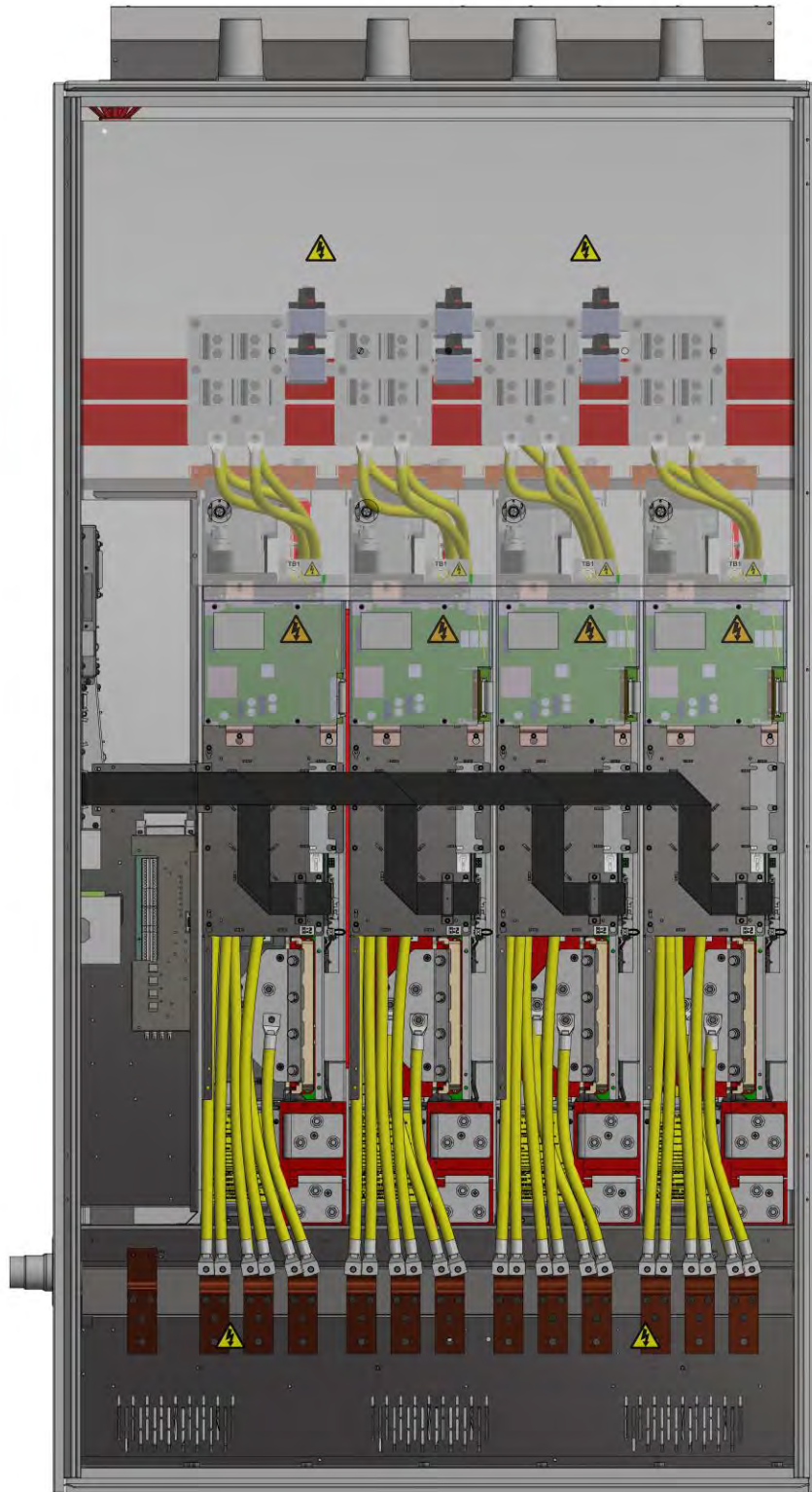

9.2 Prior to Removal of MVDL1000 DELTA Modules

- The removal process of the MVDL1000 Delta modules should follow standard on-site processes, including:
 - Power shutdown
 - Draining of liquid coolant
 - Disconnecting of all electrical power sources
 - Removal of SMPS
 - Removal of the MVDL1000 Deltas

- Before removal of any connections or components, record the positions of the following.
 - All existing cables
 - Note the position of any relevant tie wraps.
 - Identify the master SMPS for the grid and generator system. The master SMPS is mounted on the Delta module connected to PL2 of the associated CDC.
 - Keep all hardware, nuts, bolts, washers, thread protectors, etc.

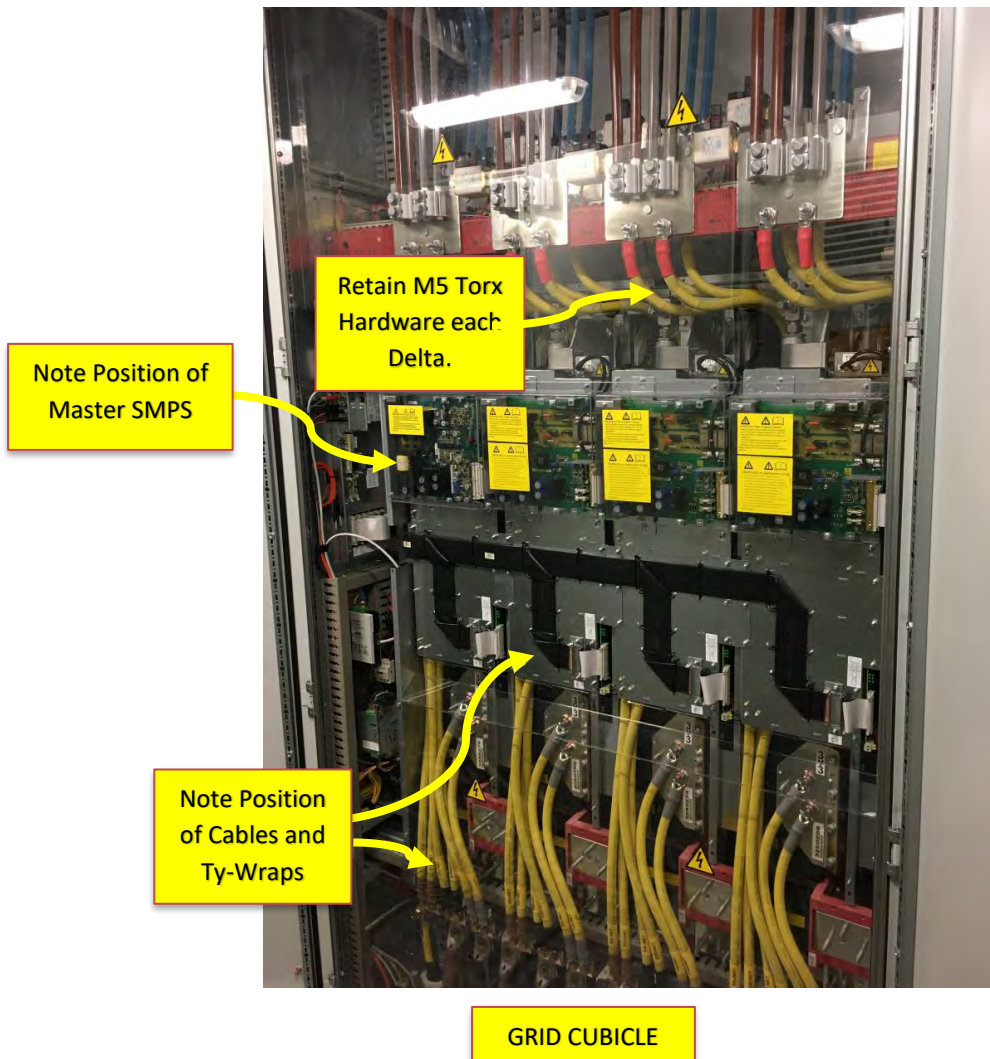

9.3 Record jumper settings

When removing the Master SMPS(s) record the positions of jumpers TP10 to TP13. These jumpers configure the over-voltage trip behavior. The AE11000L modules use this information for proper setup.

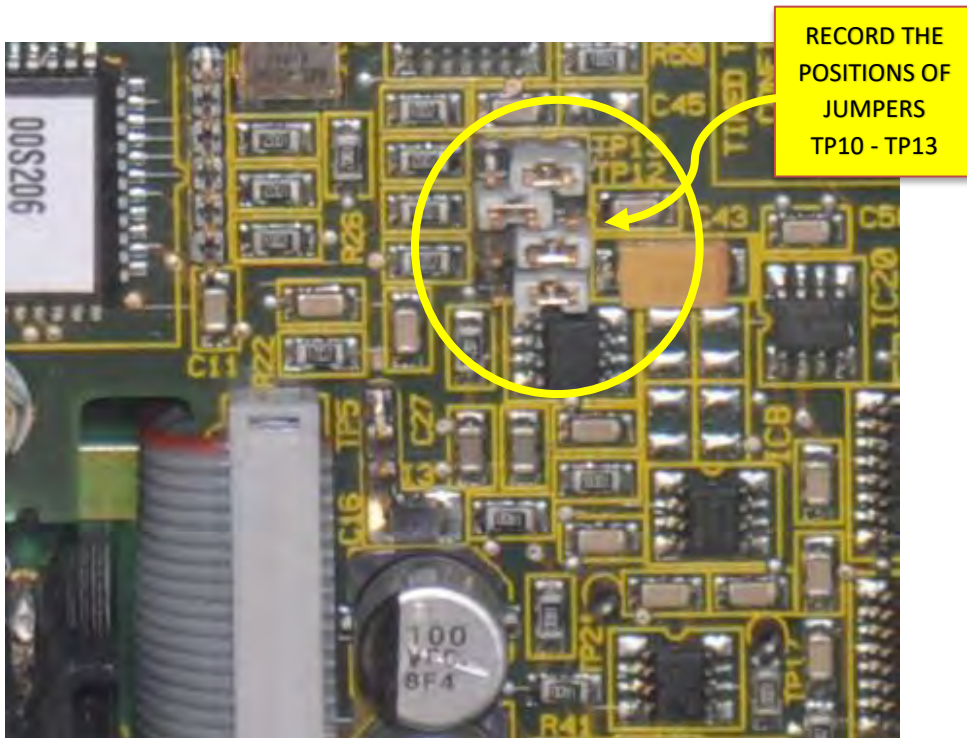

9.4 Remove Cabinet Shrouds - GRID

- Remove the upper and lower shrouds from the GRID cabinet.
- Retain all Shrouds for re-fitting after AEI installation. Note - lower shroud for GRID cabinet will require modification before re-fitting. See section 18 for modification instructions.
- Retain the fixing screws.

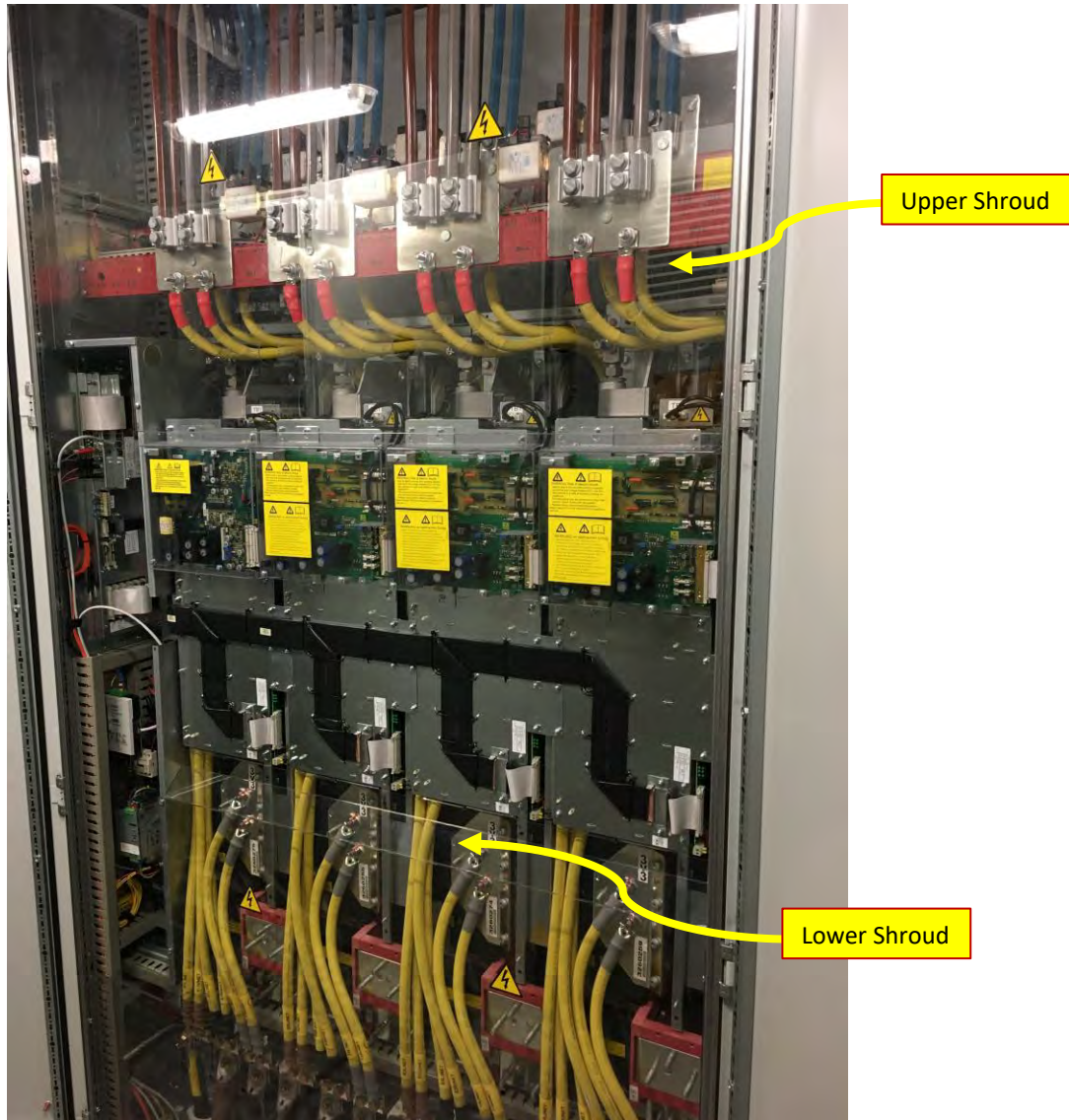

9.5 Remove SMPS & Ribbons from MVDL1000 DELTA Modules

- Disconnect and remove all ribbon cables and secure safely in control section using a Cable-tie. Ribbons will need to be refitted after installation of AEI units.
- Remove LH Bonding bracket and discard but retain M4 Taptite screws which will be needed for replacement bracket.
- Remove all SMPS Modules and SMPS mounting plates.

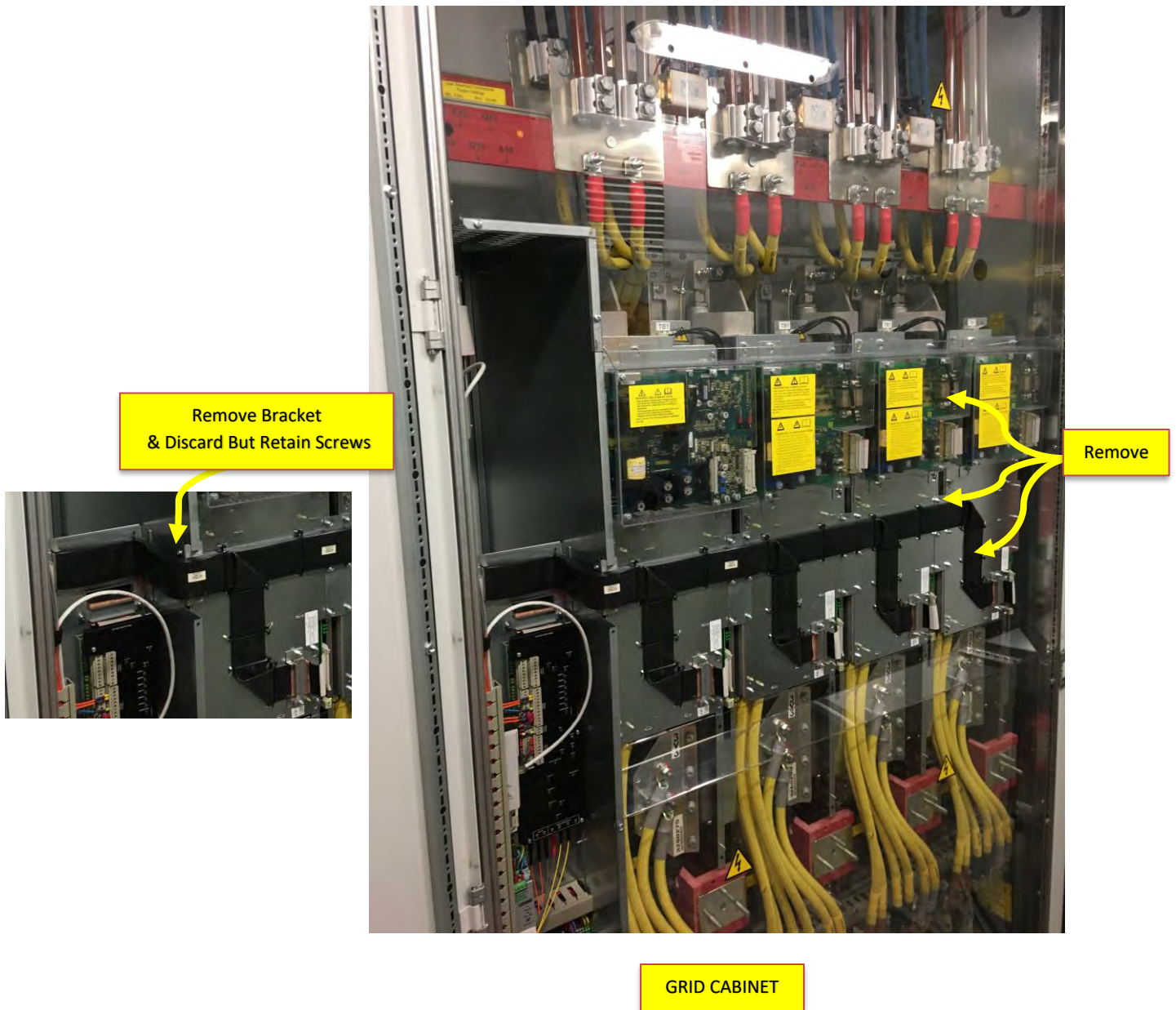

9.6 Disconnect MVDL1000 DELTA Modules

- Carefully note all power cable positions, then remove them:
- Disconnect DC cables from upper fishplates but leave cables attached to Delta module.

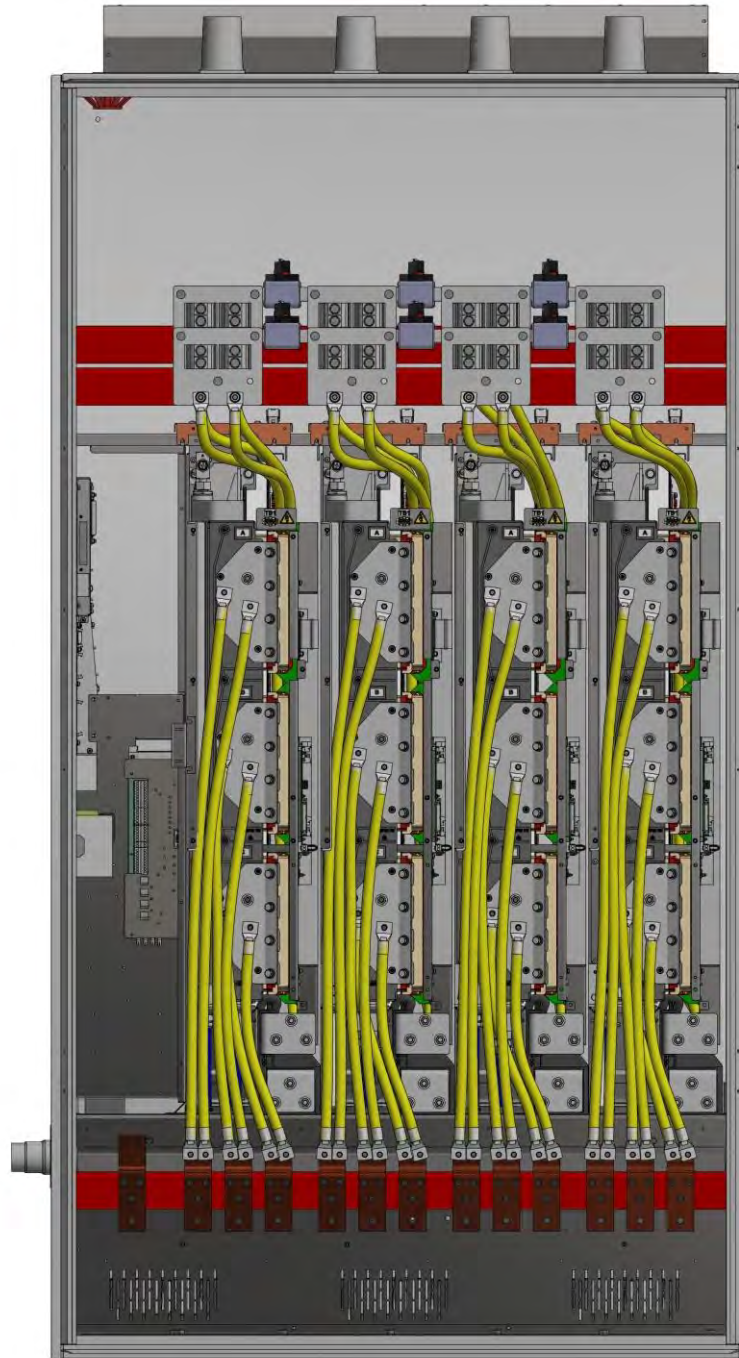

GRID CABINET

9.7 Remove covers to access coolant pipes.

- Remove Splash Shroud from Delta to expose coolant pipes
- Loosen clamps and disconnect coolant pipes from Delta Module

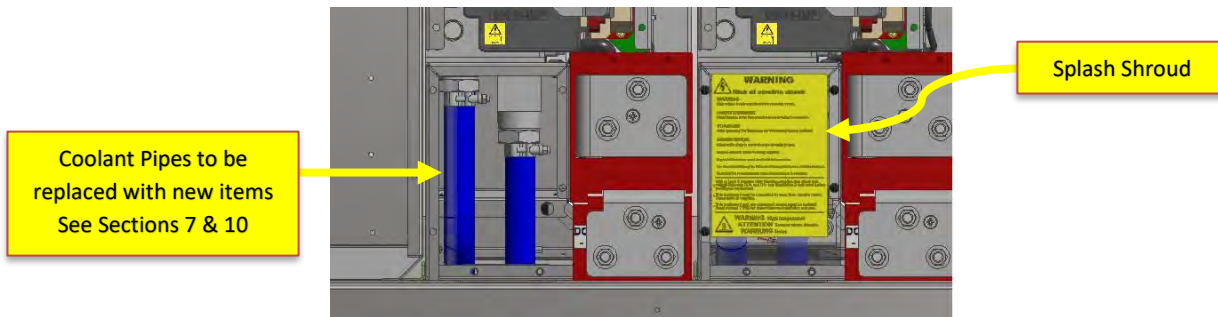
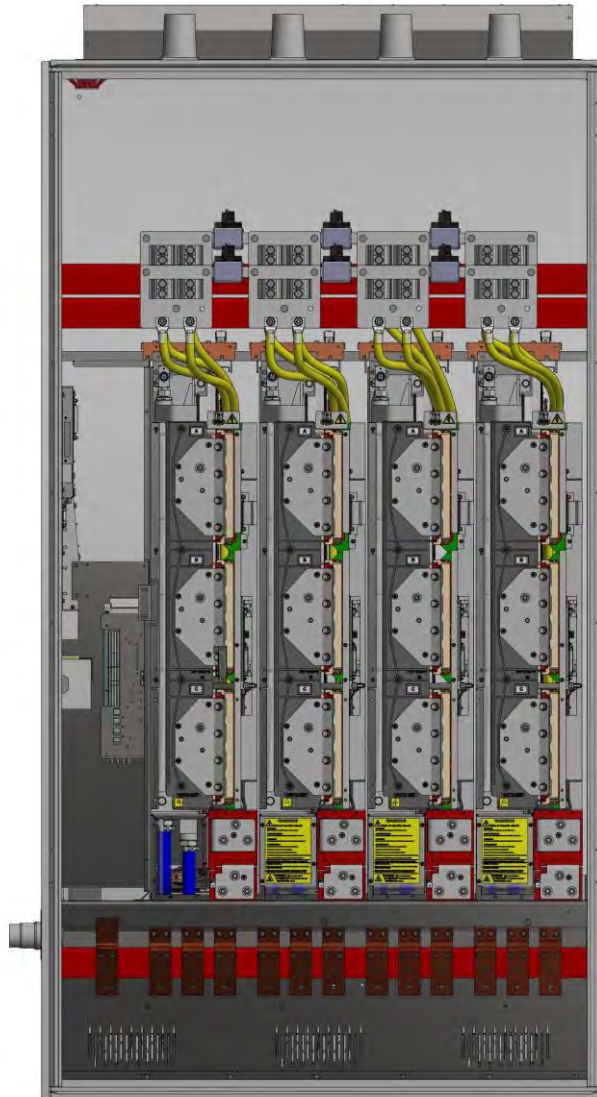

9.8 Remove Grid MVDL1000 DELTA Modules, Replace Hoses

- Remove all DELTA modules as shown, this will allow access to the lower hoses, shown below.
- Replace all 8 hoses & clips using those provided in the AEI upgrade kit.

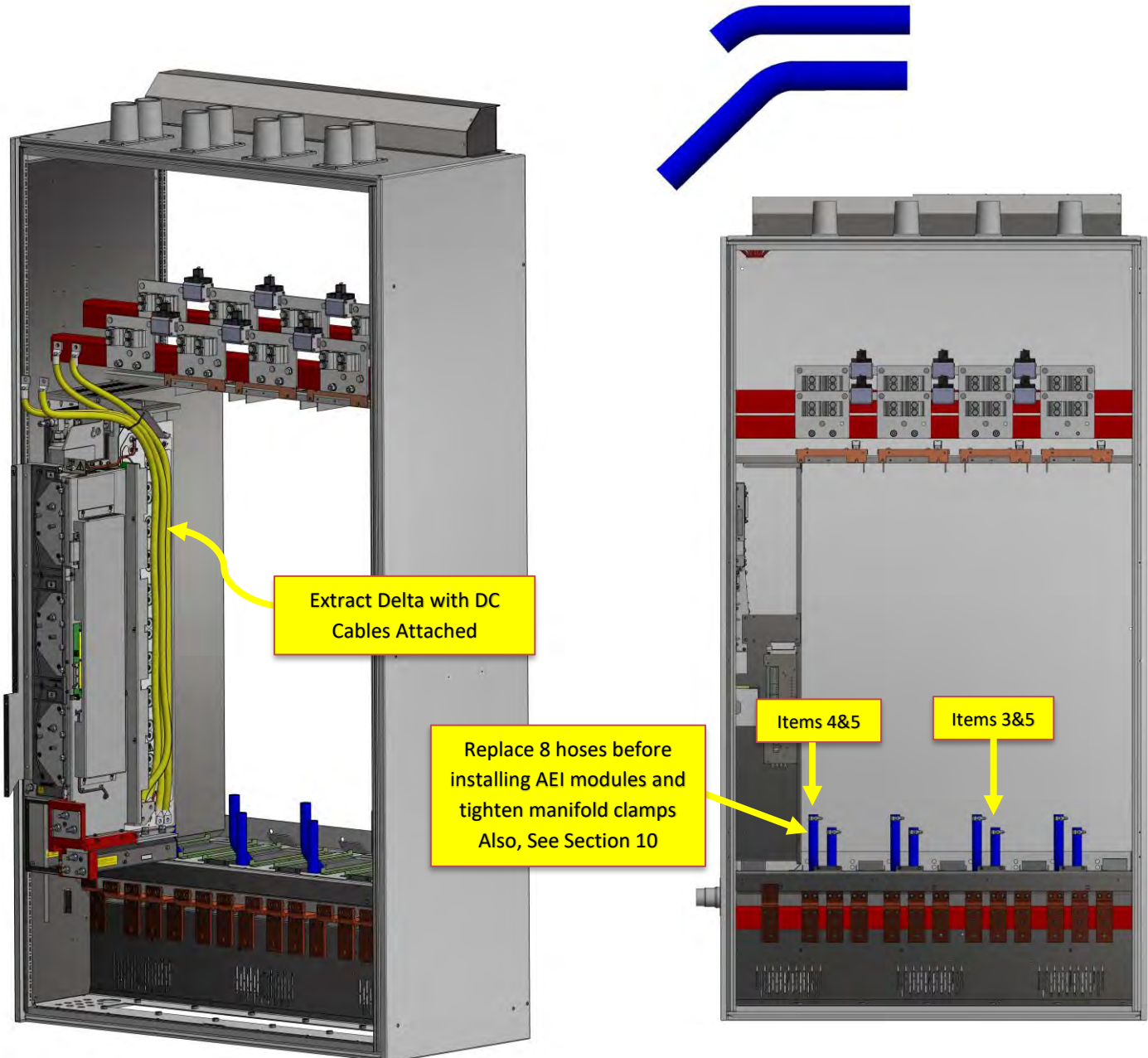

- **IT IS CRITICAL THAT THE HOSES ARE SECURELY INSTALLED AND THE CLAMPS TIGHTENED CORRECTLY. COOLANT LEAKAGE WILL IRREPARABLY DAMAGE THE INVERTER UNITS. TIGHTEN CLAMPS TO 4Nm USING TORQUE TOOL PROVIDED - DO NOT OVERTIGHTEN**



10. Modify Side Panel

- In order to allow new grounding bracket and Ribbons to fit, remove metal section from LH shielding Panel as shown below. Use the recommended nibbling tool or equivalent to cut the panel
DO NOT remove panel from cabinet, implement modification with panel in situ
Ensure suitable precautions are taken to prevent metal particles (swarf) from contaminating cabinet.

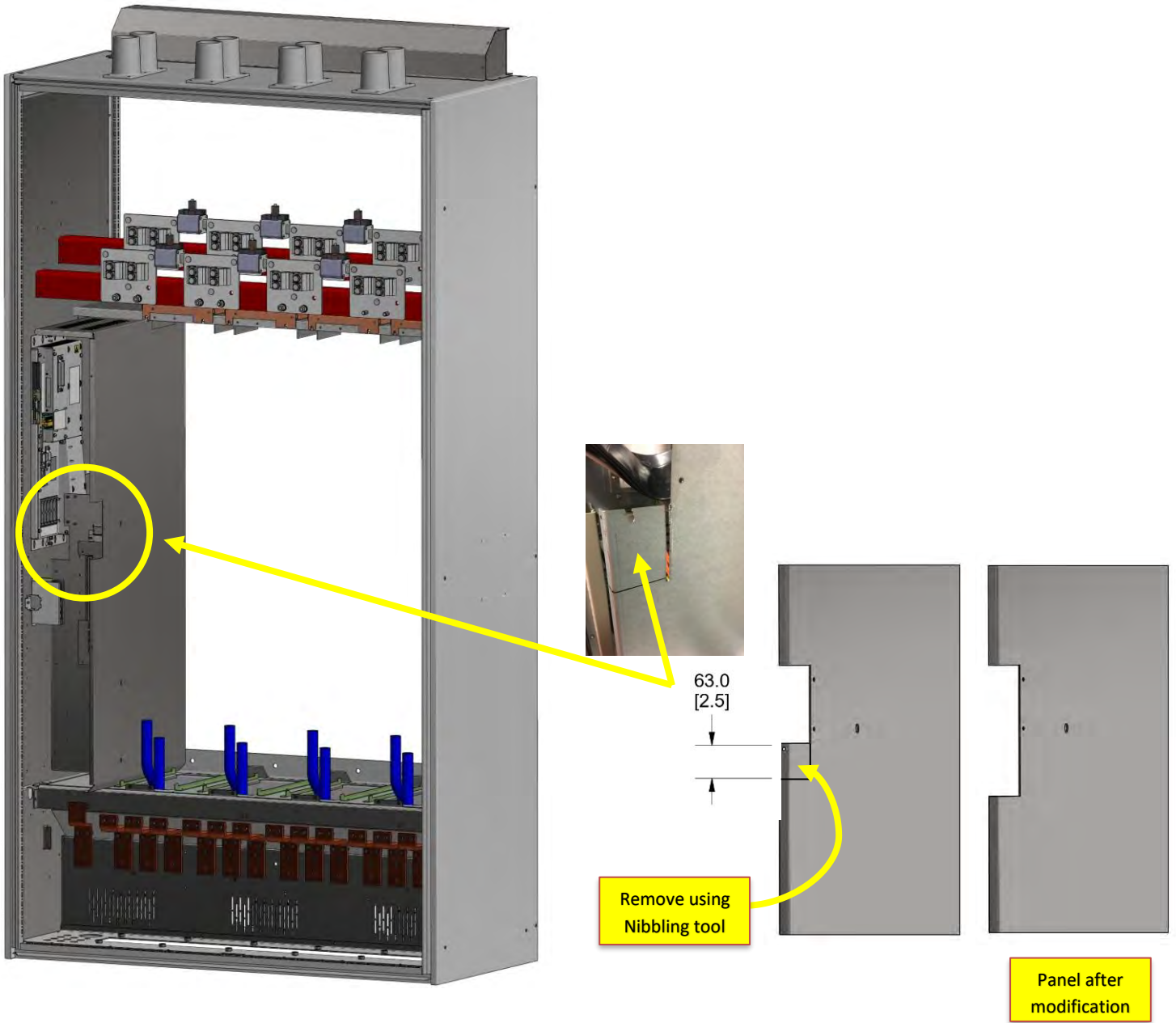

11. Install AEI 1000L Modules Grid Cabinet

11.1 Set AEI DIP Switches

- Before the Installation of each AEI verify that DIP switches 1-4 (which configure the overvoltage behavior) on each AEI are set to the equivalent time setting as recorded in Step 9.3 - Master SMPS Jumpers TP10 to TP13

SMPS Jumpers	AEI Switch
TP10	SW1
TP11	SW2
TP12	SW3
TP13	SW4

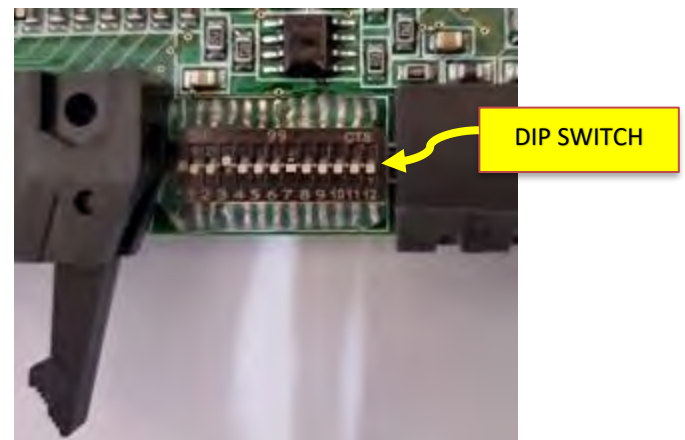
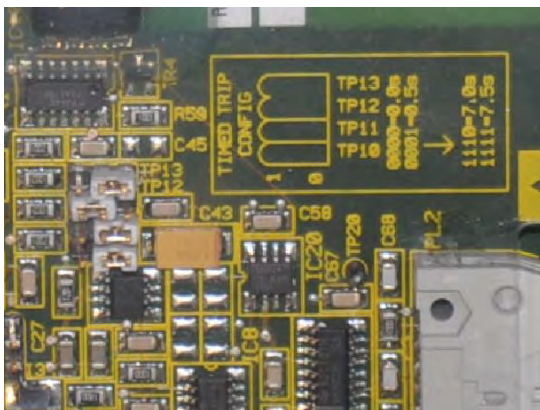

- Before the Installation of each AEI ensure that *Compatibility Rating Mode* is disabled by setting DIP switch SW7 to the **OFF** position.
- *Refer to AVID Document DTS-MID0012 section on User Selectable Options for complete information about these settings.*

THESE SETTINGS ARE IMPORTANT, THE TURBINE WILL NOT RUN CORRECTLY UNLESS THEY ARE MADE

11.2 Prepare 4 x AEI 1000L Modules for Installation into Grid Cabinet

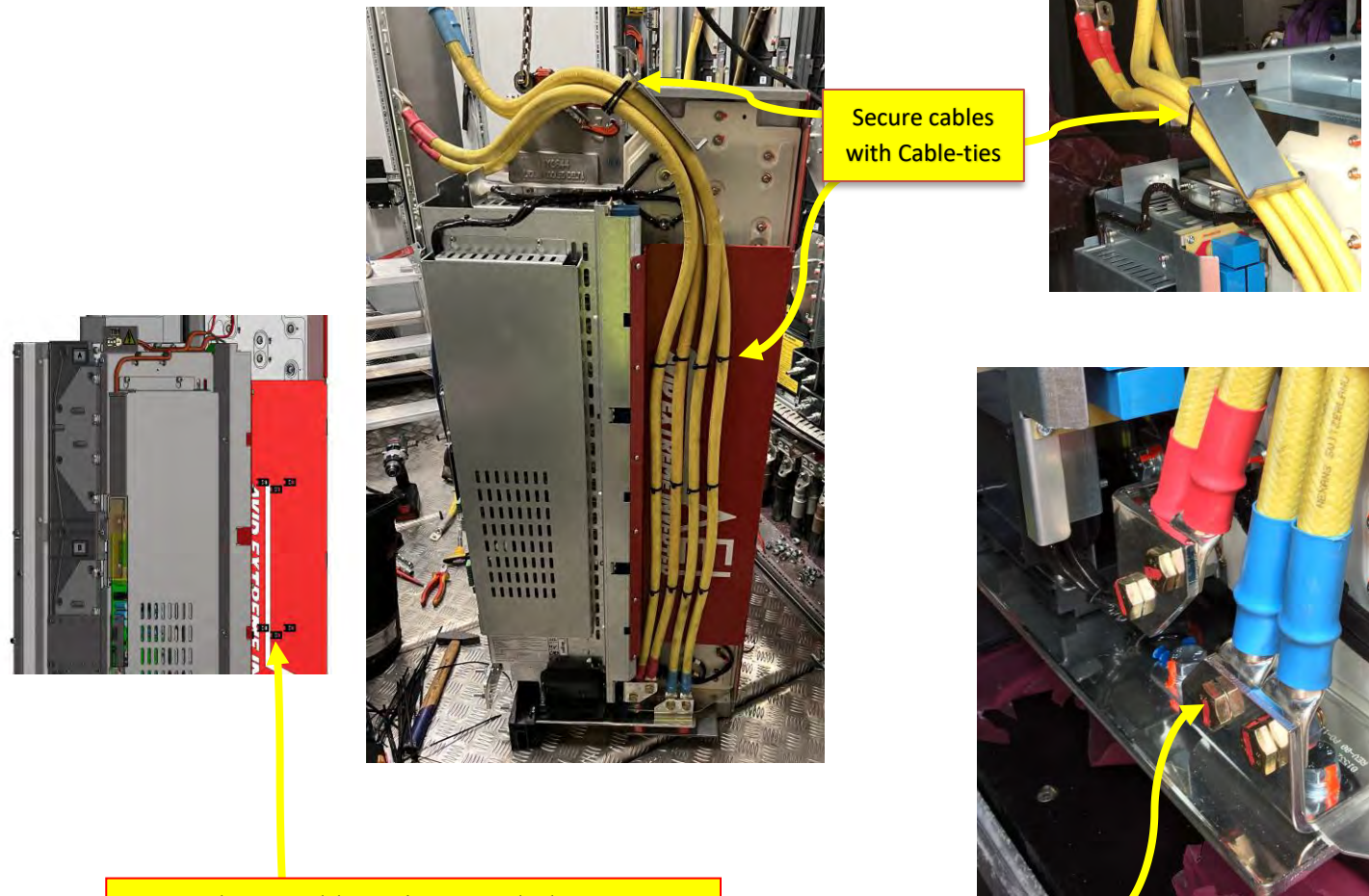
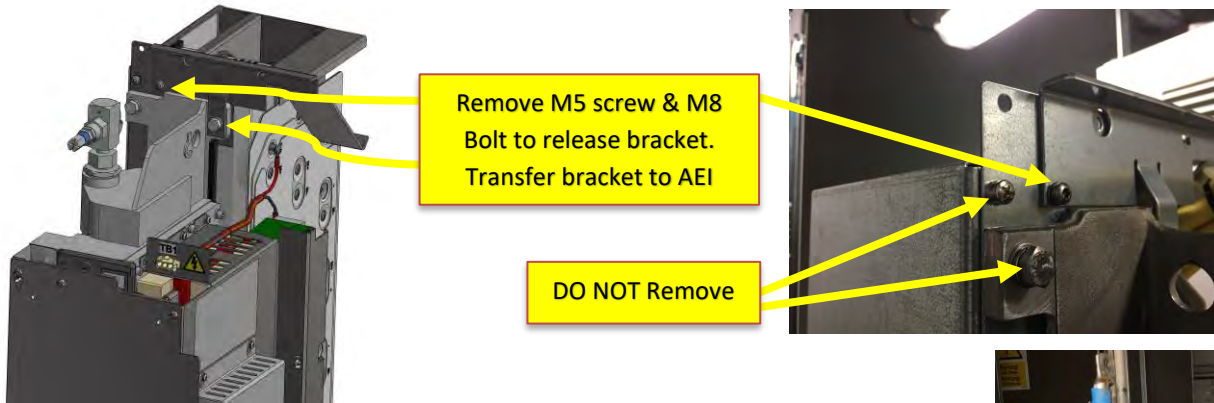

Reattach DC cables using M10 bolts & SEMS Nuts as shown. Secure cables to upper bracket using cable tie supplied with Kit. Ensure cables are tied to Cable-tie bases on red cover using Cable ties supplied.

M10x25 Bolt, M10 SEMS Nut
Torque to 35N/m (310lb.in)



11.3 Install 4 AEI 1000L Modules into the GRID Cabinet.

- Align with the M5 and M6 mounting locations used by the DELTA modules, firmly secure the AEI units with the M5 Torx screws and M6 bolts/washers retained when the DELTA modules were removed.
- Remove front cover plates in preparation for power cabling

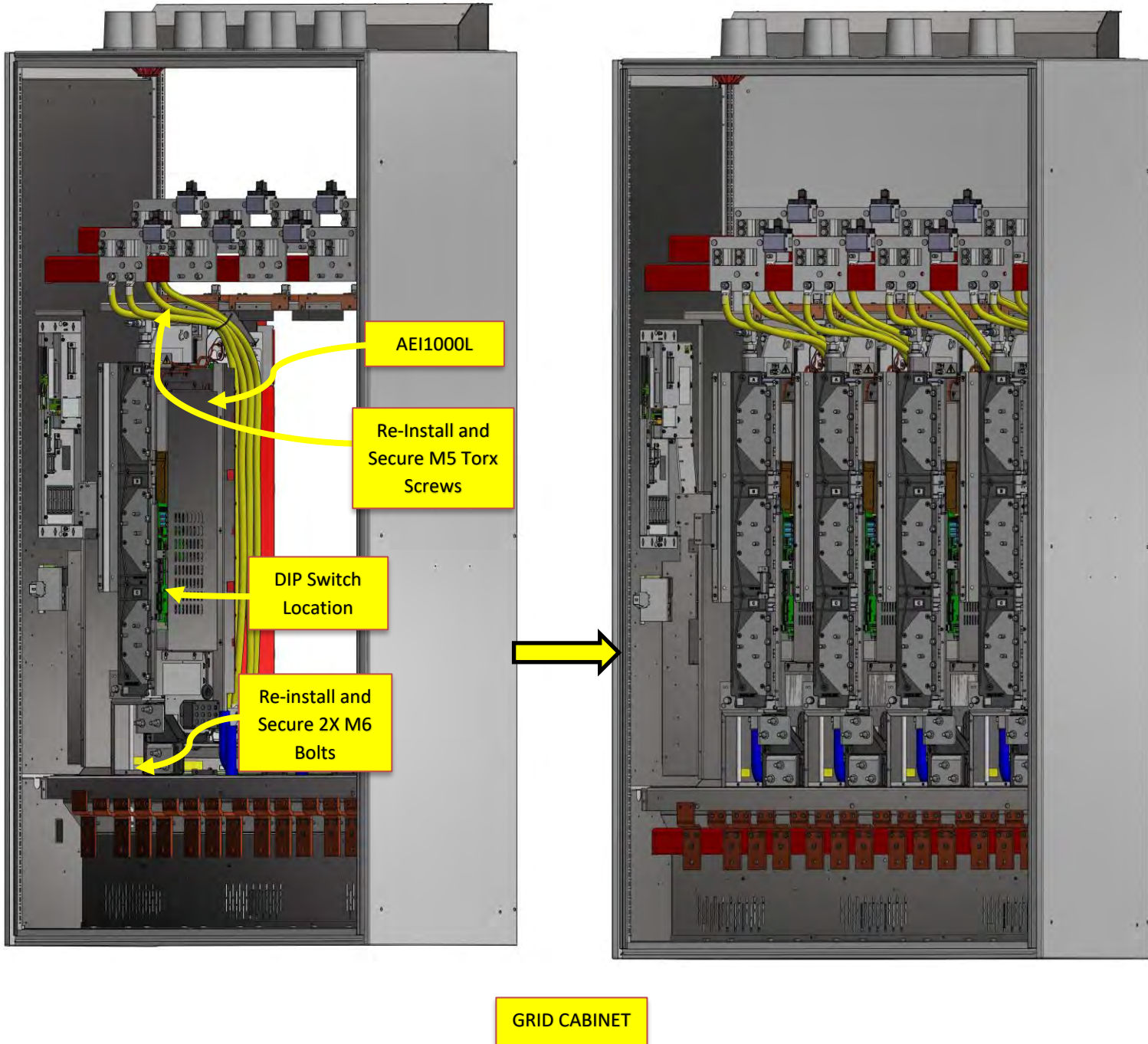

12. Connect Coolant Hoses

- Connect and secure each hose from the inlet manifold to the bottom barbs on all the AEI units.

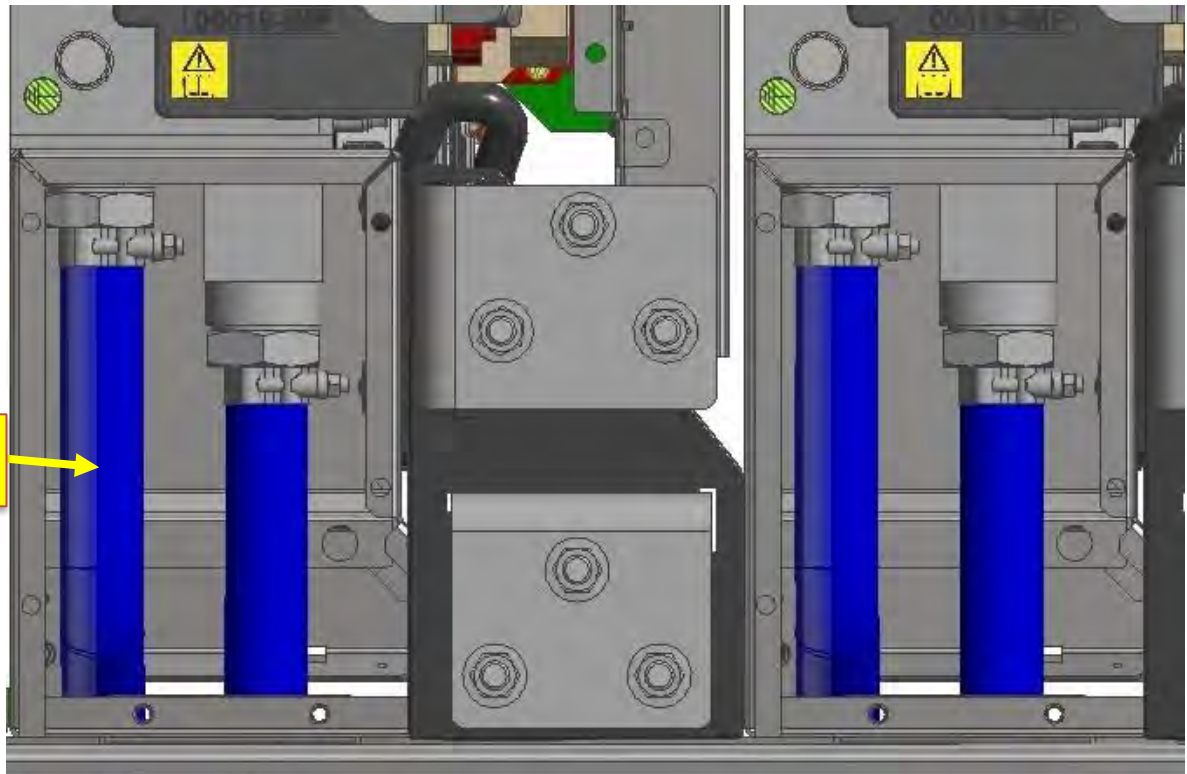

- **IT IS CRITICAL THAT THE HOSES ARE SECURELY INSTALLED AND THE CLAMPS TIGHTENED CORRECTLY. COOLANT LEAKAGE WILL IRREPARABLY DAMAGE THE INVERTER UNITS.**
TIGHTEN CLAMPS TO 4Nm USING TORQUE TOOL PROVIDED - DO NOT OVERTIGHTEN



- Replace the splash shroud on each AEI



13. Reconnect DC Cables

- Reconnect all the DC negative and DC positive front and rear cables to UPPER Fishplates using the supplied M10 flange nuts. Torque down all connections to 35Nm (310lb.in)

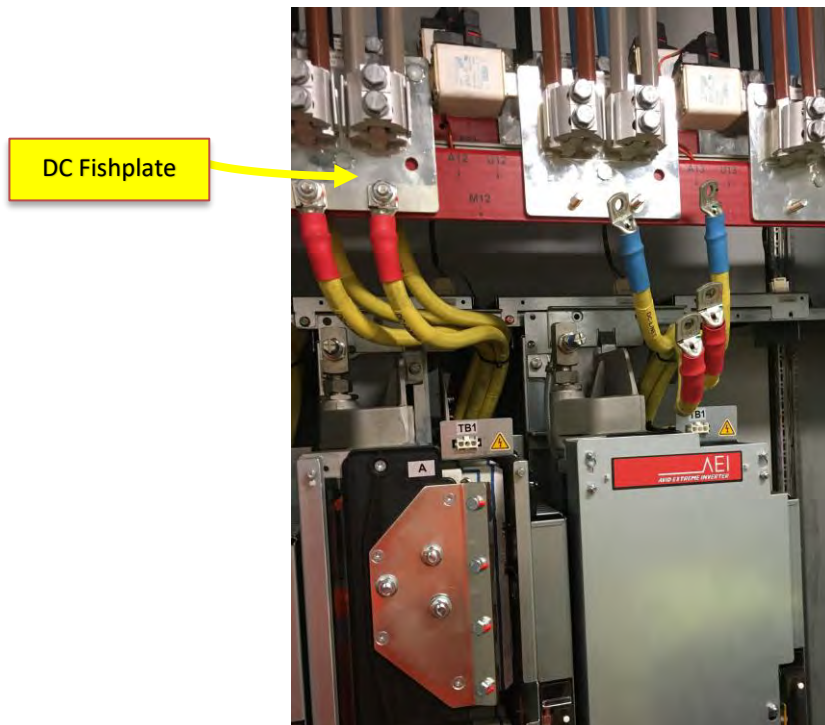

14. Reinstall Grid Cubicle AC Cables

- Reinstall the GRID cubicle AC cables in the same locations identified on removal, using the supplied M10 flange nuts. Torque all connections to 35Nm (310lb.in).

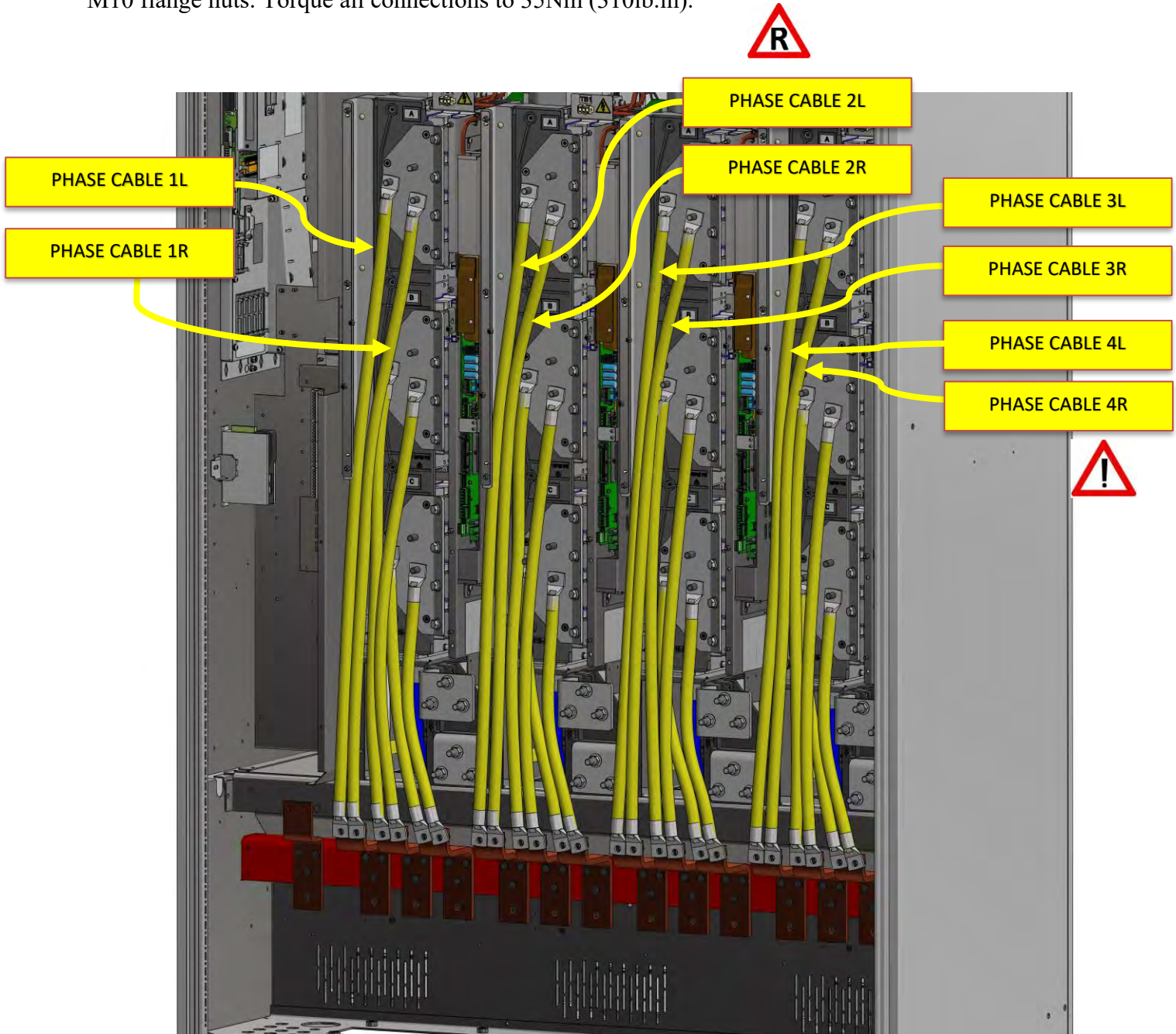

15. Install Ground Bonding Brackets and Ribbon Cables

- Install the offset ground bracket (*Item 2*) using original M4 x 6 screws, this will allow the routing of the ribbon cables from the AEI1000 modules into the control Section
- Take care to use the correct bracket for the Grid cubicle.

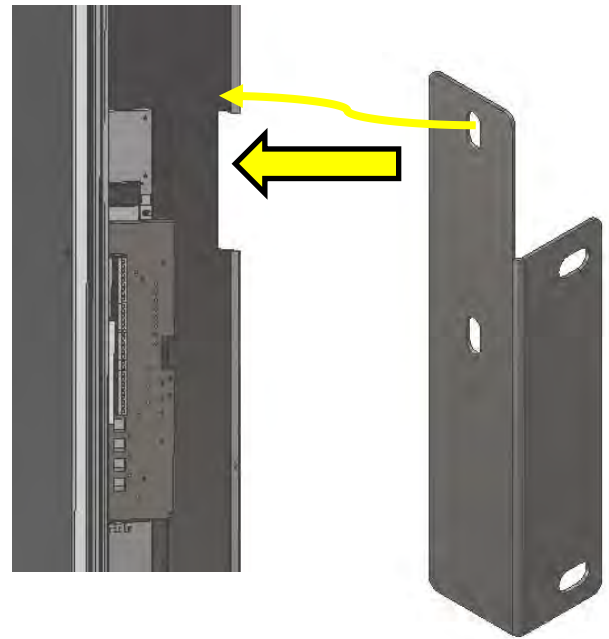

ITEM 2 – Grid Side



2 Off M4x6 TAPTITE (Retained from Original)

ITEM 2 – Grid Side

16. Install Auxiliary Power Units, Grid Cabinet

- For each APU, plug the 4-pin connector into the corresponding AEI module:

AEI-APU-G X4
ITEM 1

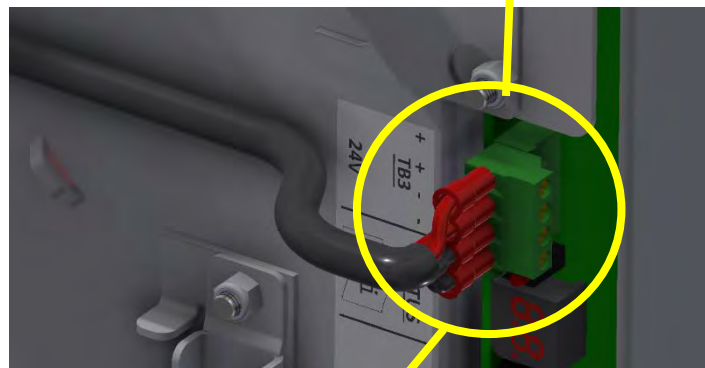
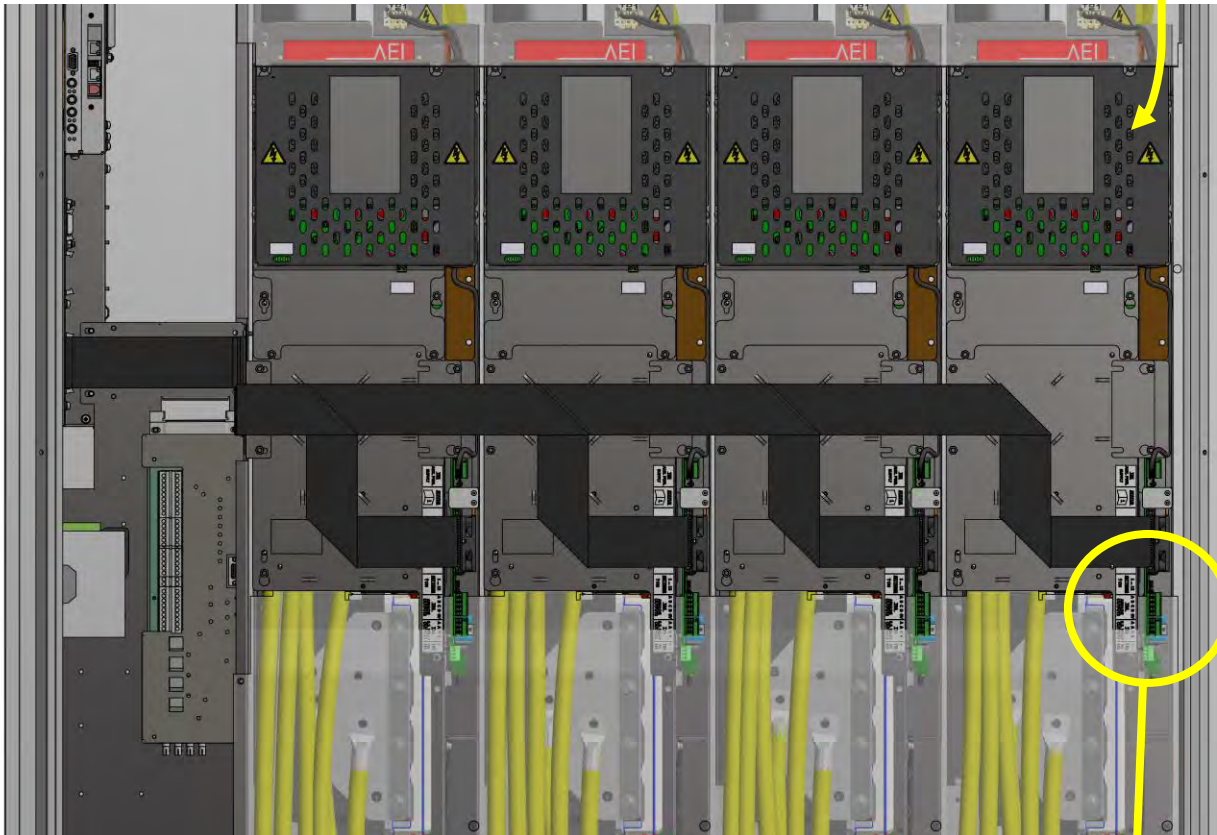

4 Pin Connector to
TB3. Install as Shown.

17. Optional Connection of Auxiliary 24VDC Supply to APUs

- The AEI modules and CDCs may be powered from an auxiliary 24VDC supply, connected to the $\begin{array}{c} + \\ \text{AUX. 24V DC} \\ - \end{array}$ input of the APU-G units.
- **Refer to Section 6 of the Auxiliary Power Unit – Type G Data Sheet (DTS-02175-ASY-A) for complete details.**
- Attention is drawn specifically to:
 - The rating of the auxiliary 24VDC supply must be adequate for the startup current of the AEs.
 - If the auxiliary 24VDC supply to the APUs is used, it is recommended to disconnect the auxiliary 24VDC supply to the CDCs from TB2 on the I/O panels.

18. Modify GRID Shroud

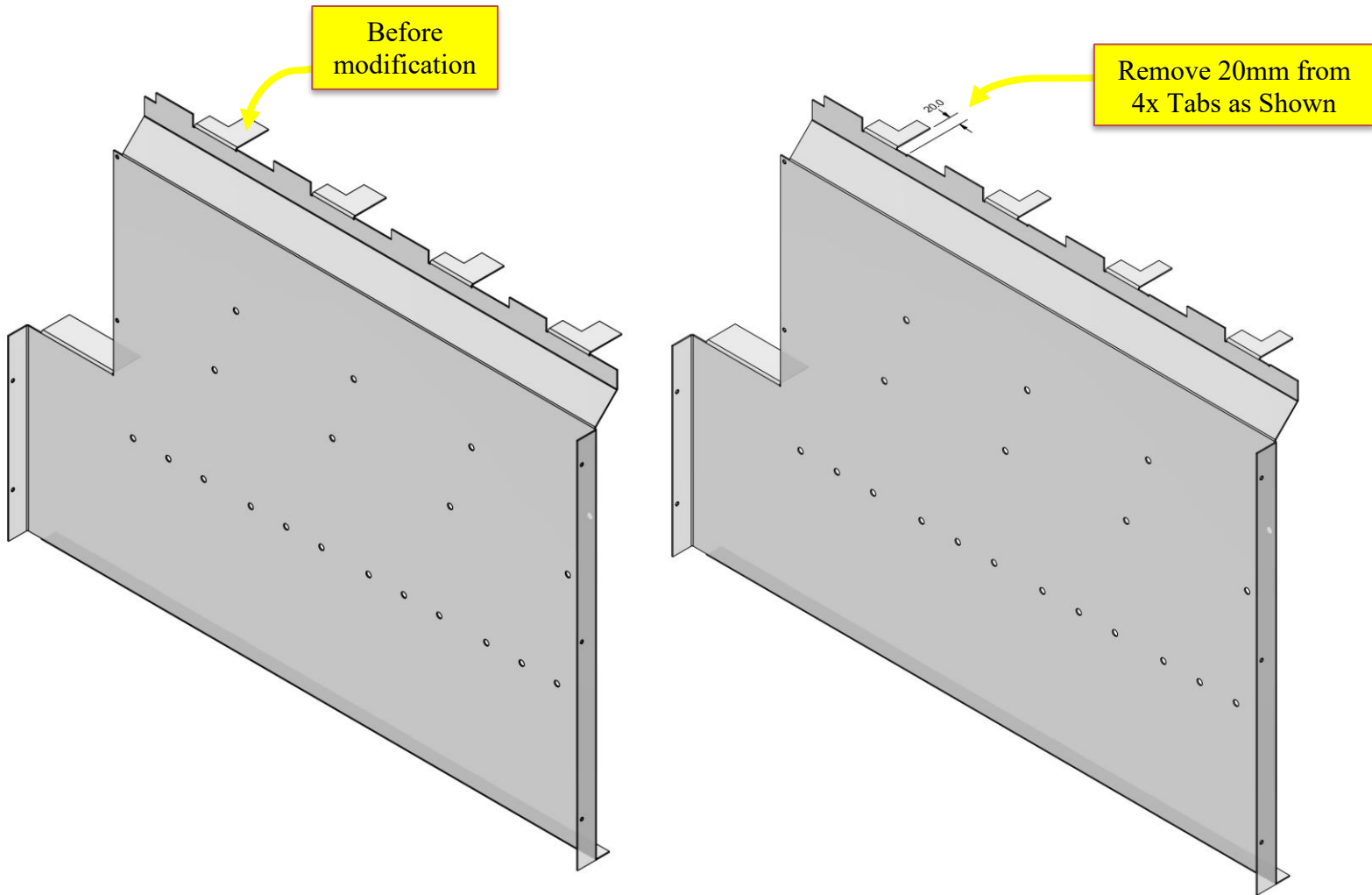

19. Refit Cubicle Shrouds

Re-Install Upper
Shroud

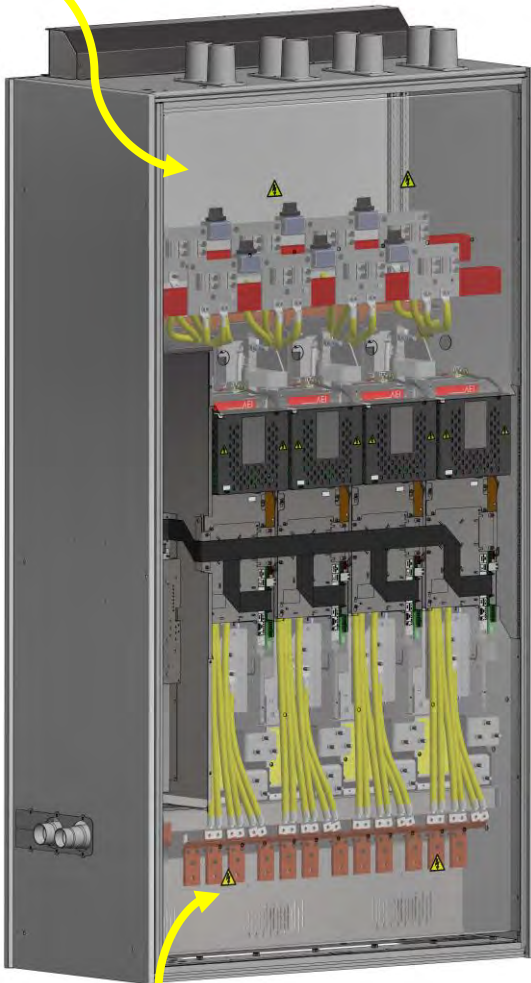

Re-Install Lower
Shroud

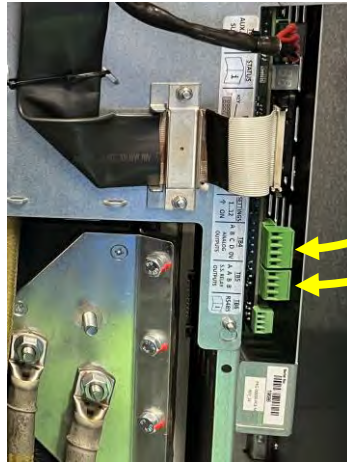

If Fitted, Remove These Two
Connector Plugs from Each AEI
Before Fitting Into Cubicle

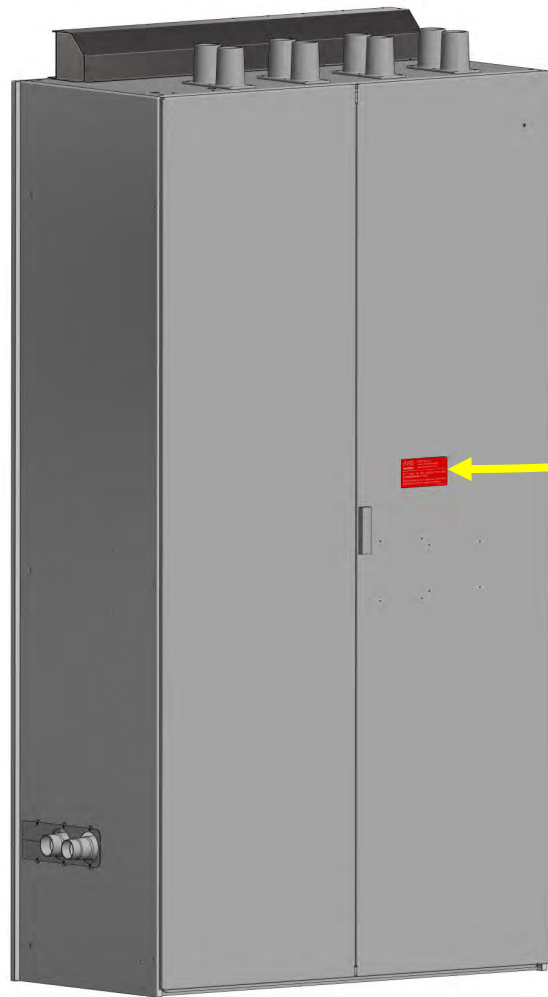

Fit Label (*Item 7*)
To Front Door

20. Nacelle Layout

<i>Ref</i>	<i>Contains</i>
A13	Generator Inverter
A3	Main Computer and Relay Box
A18	Frequency Converter for Yaw Motors

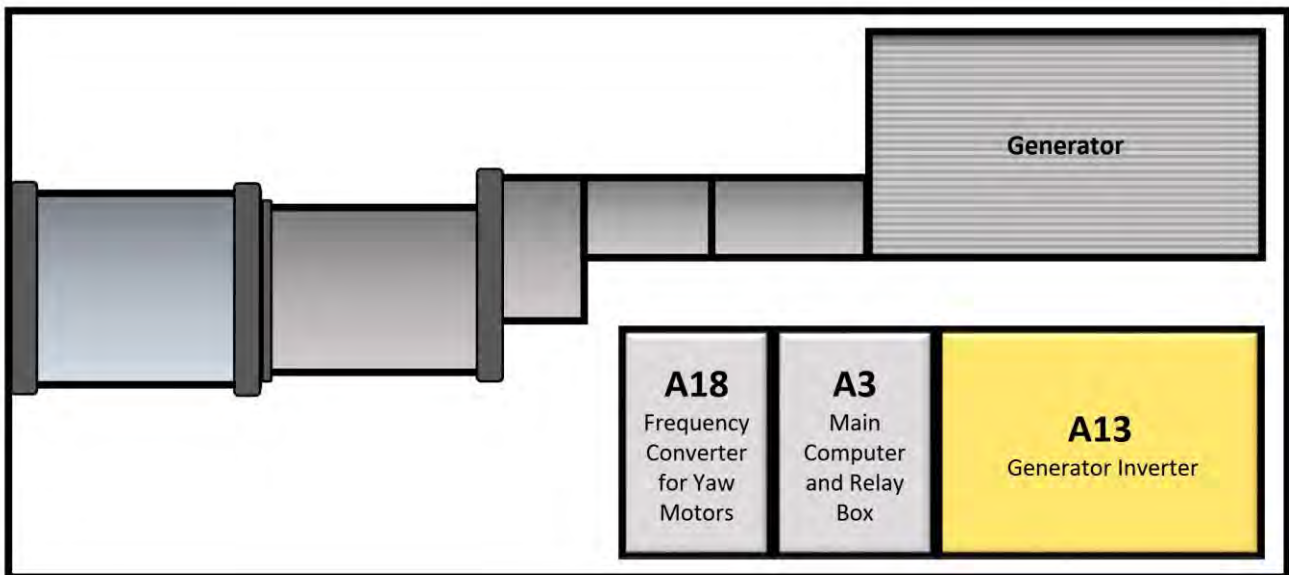

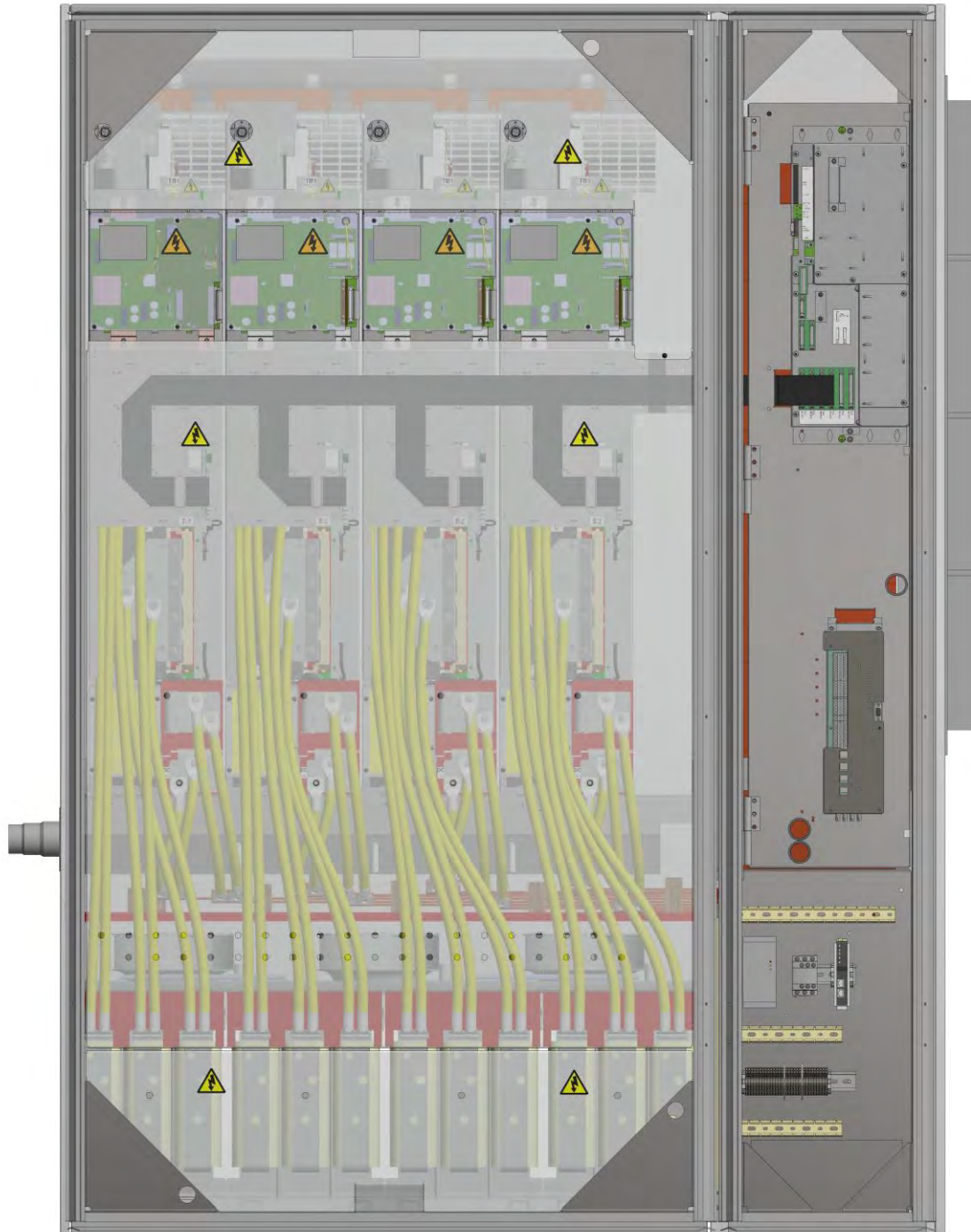

Cabinet A13 Gen Frequency Converter

20.1 Prior to Removal of MVDL1000 DELTA Modules

- The removal process of the MVDL1000 Delta modules should follow standard on-site processes, including:
 - Power shutdown
 - Draining of liquid coolant
 - Disconnecting of all electrical power sources
 - Removal of SMPS
 - Removal of the MVDL1000 Deltas
- Before removal of any connections or components, record the positions of the following.
 - All existing cables
 - Note the position of any relevant tie wraps.
 - Identify the master SMPS for the grid and generator system. The master SMPS is mounted on the Delta module connected to PL2 of the associated CDC.
 - Keep all hardware, nuts, bolts, washers, thread protectors, etc.

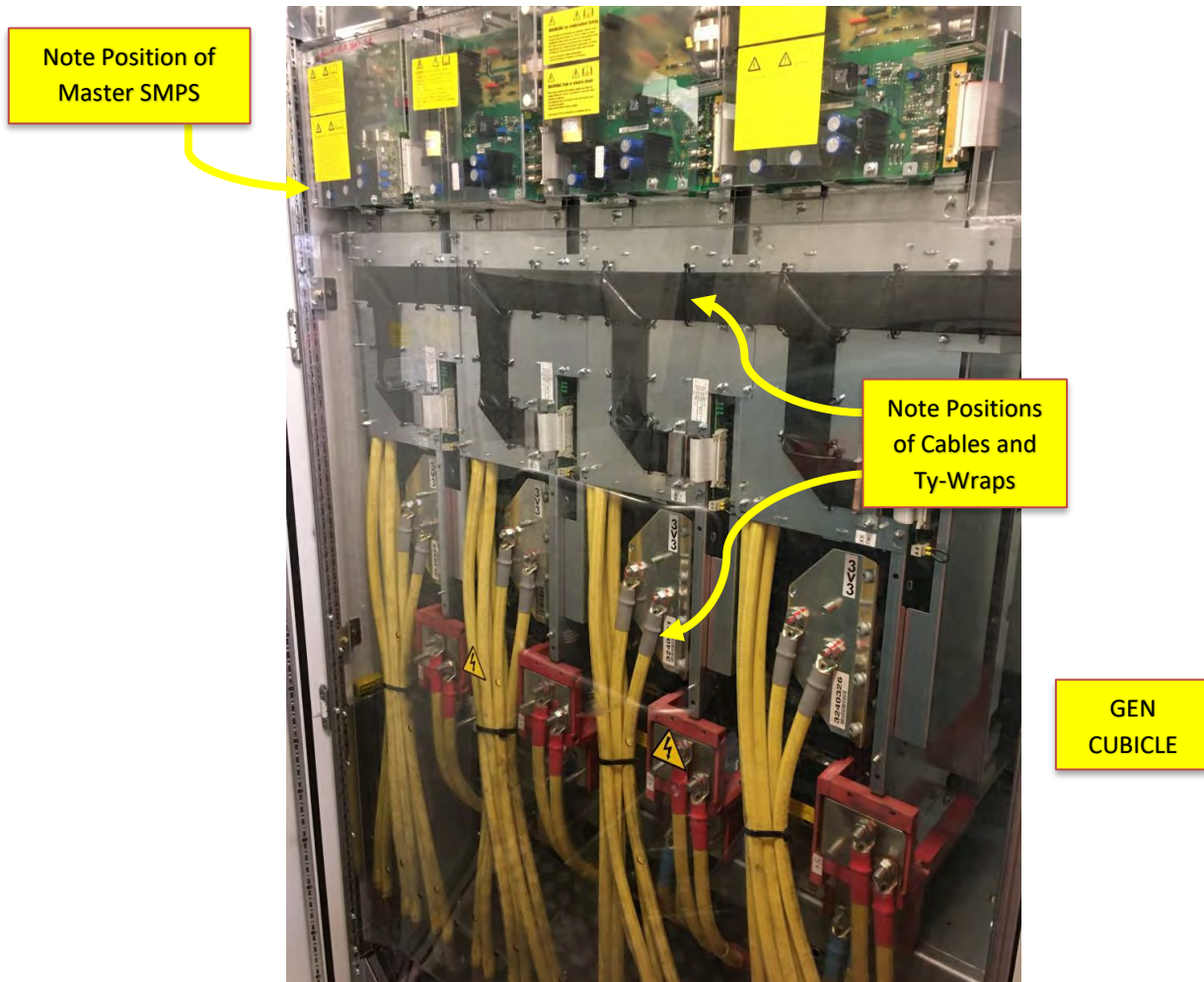

20.2 Record jumper settings

When removing the Master SMPS(s) record the positions of jumpers TP10 to TP13. These jumpers configure the over-voltage trip behavior. The AEI1000L modules use this information for proper setup.

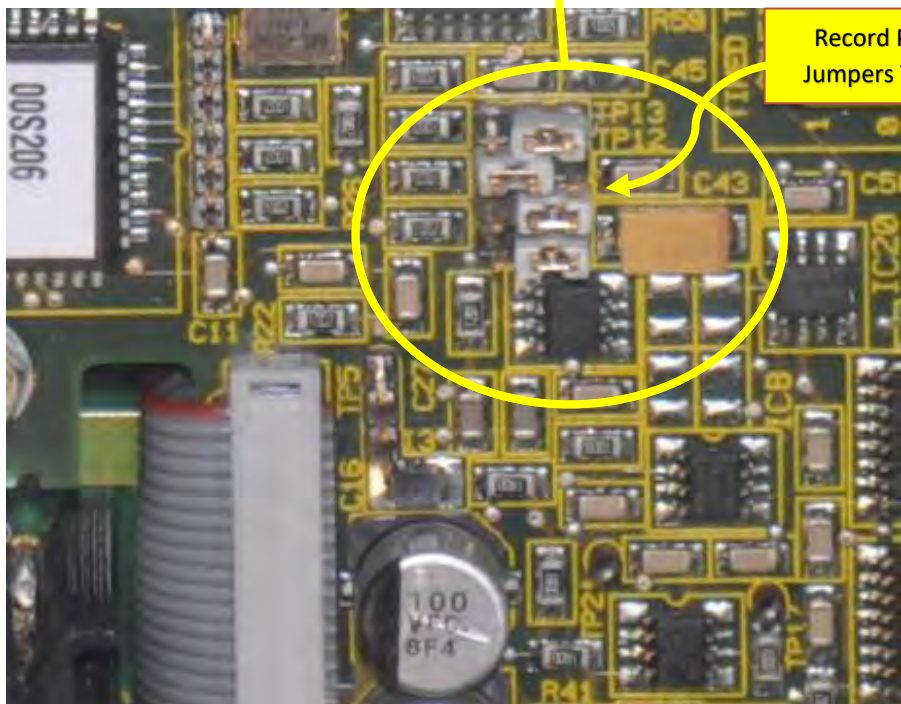
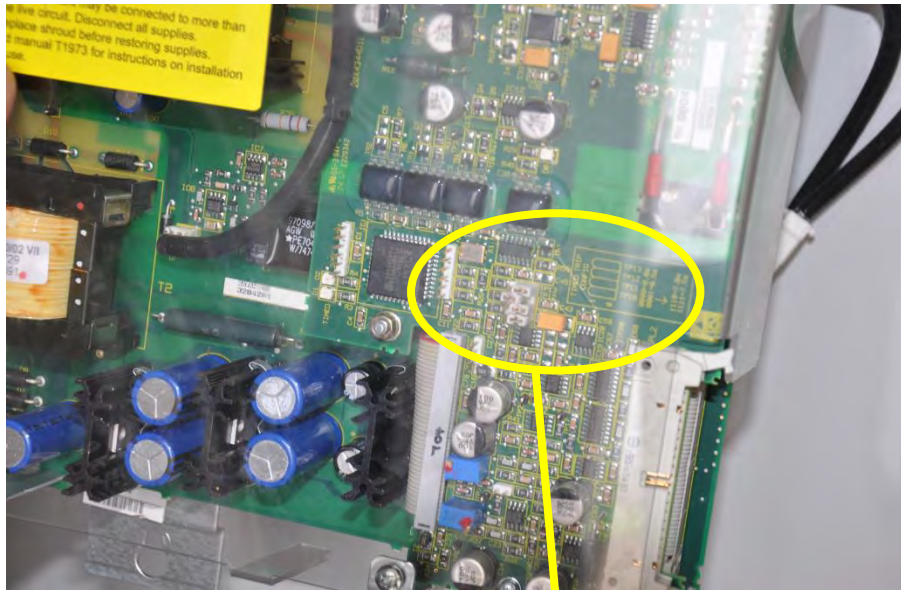

20.3 Remove Cabinet Shrouds, GEN

- Remove the upper, middle and lower polycarbonate shrouds from the front of the GEN cabinet.
- Remove upper left corner strengthening bracket from GEN cabinet (If Fitted)
- Retain all Shrouds for re-fitting after AEI installation.
- Retain the fixing screws and corner bracket.

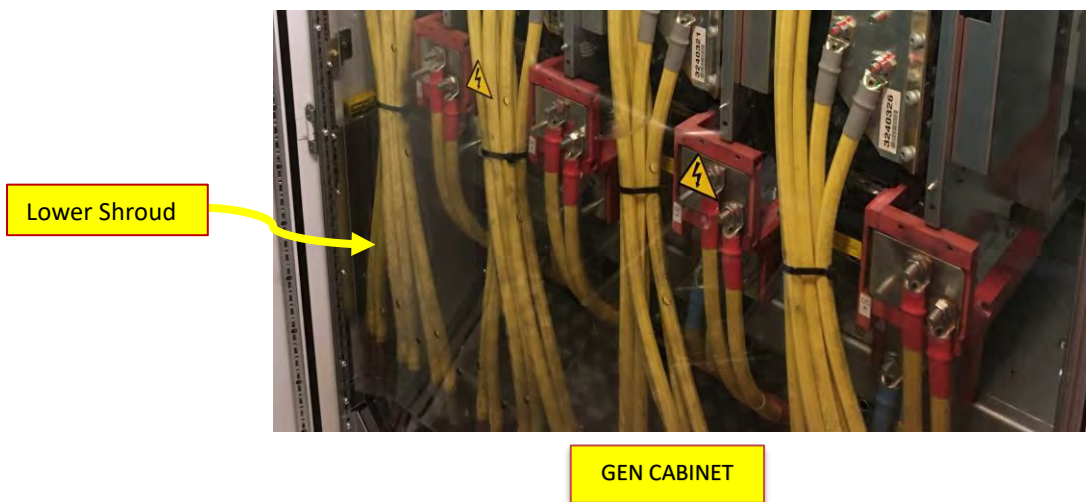
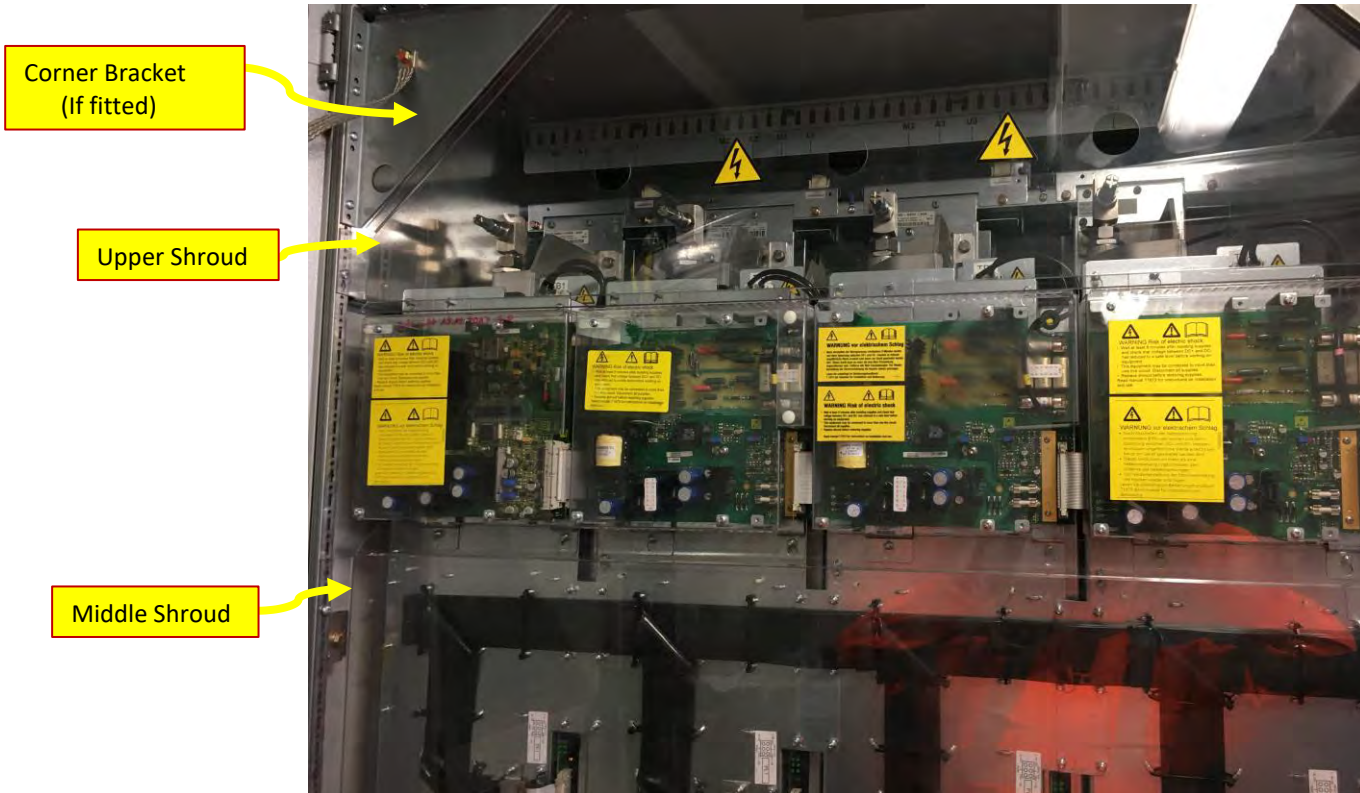

20.4 Remove SMPS & Ribbons from MVDL1000 DELTA Modules

- Disconnect and remove all ribbon cables, these will need to be replaced after installation of AEI units.
- Remove all SMPS Modules and SMPS mounting plates.
- Remove Delta GROUNDING Bracket, (screws behind hinged gate in GEN control cabinet), Retain Screws for re-use.

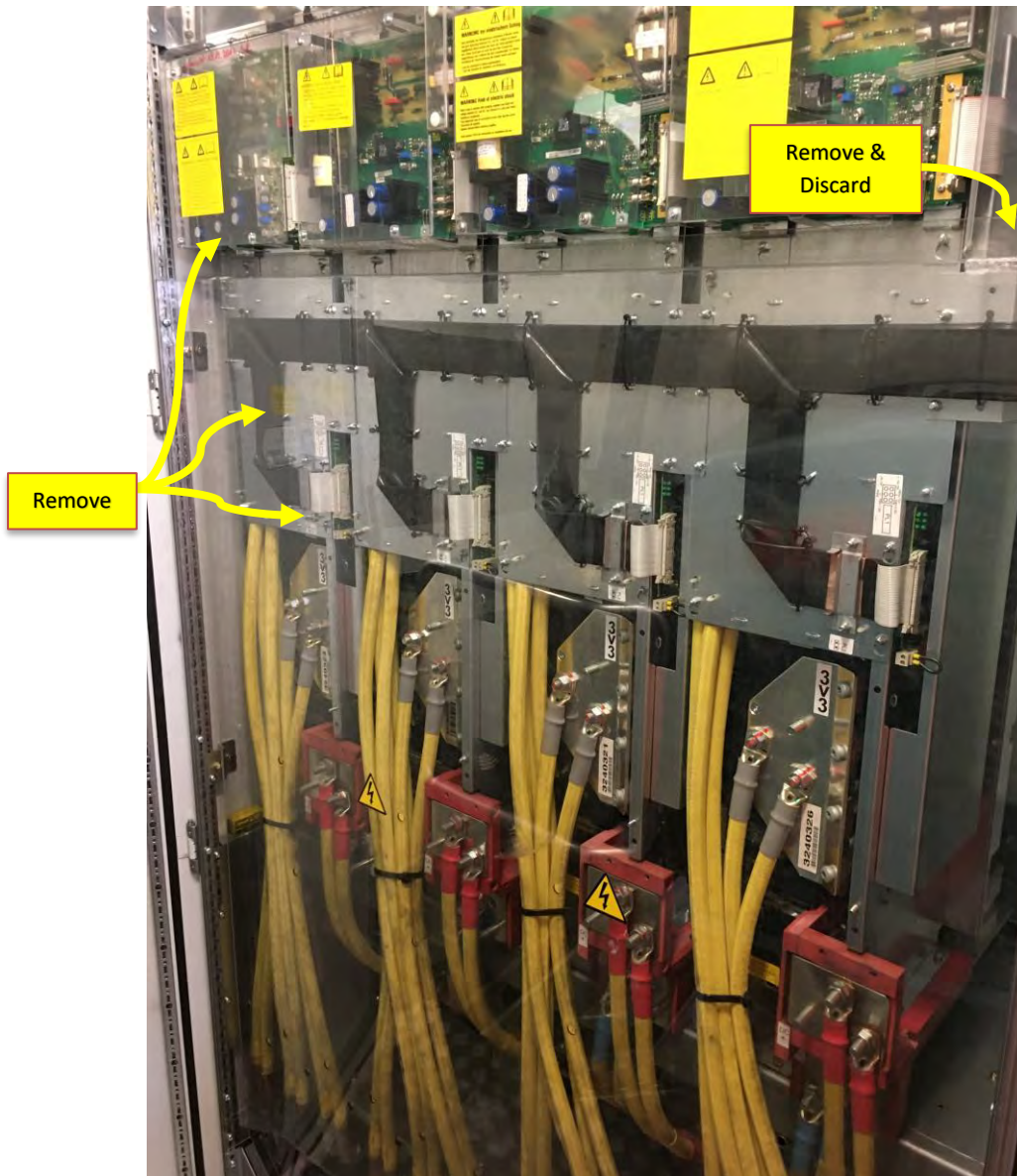

GEN CABINET

20.5 Disconnect MVDL1000 DELTA Modules

- Disconnect AC & DC power cables from each Delta and carefully fold down out of the way:

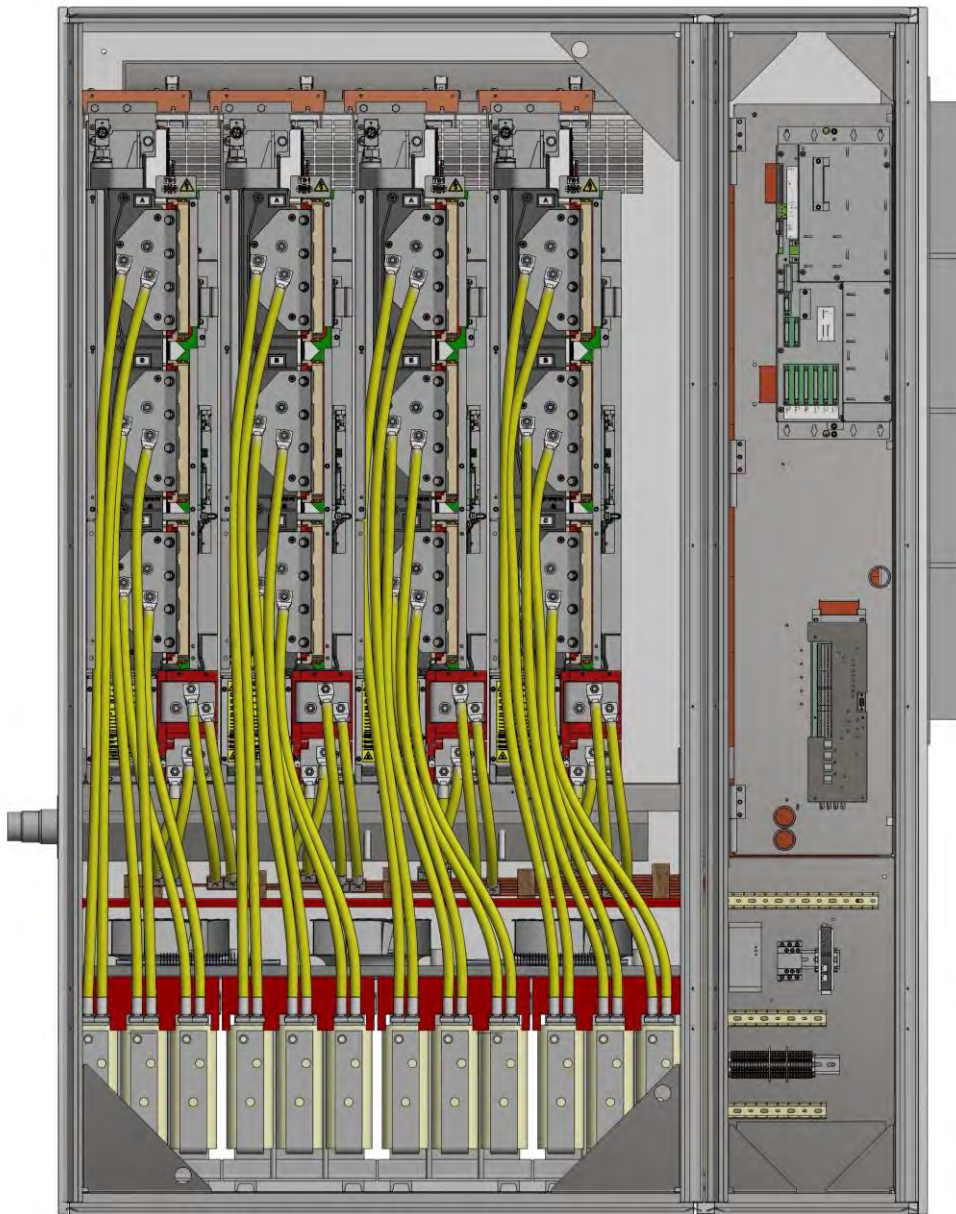

GEN CABINET

20.6 Remove covers to access coolant pipes.

- Remove Splash Shroud from Delta to expose coolant pipes
- Loosen clamps and disconnect coolant pipes from Delta

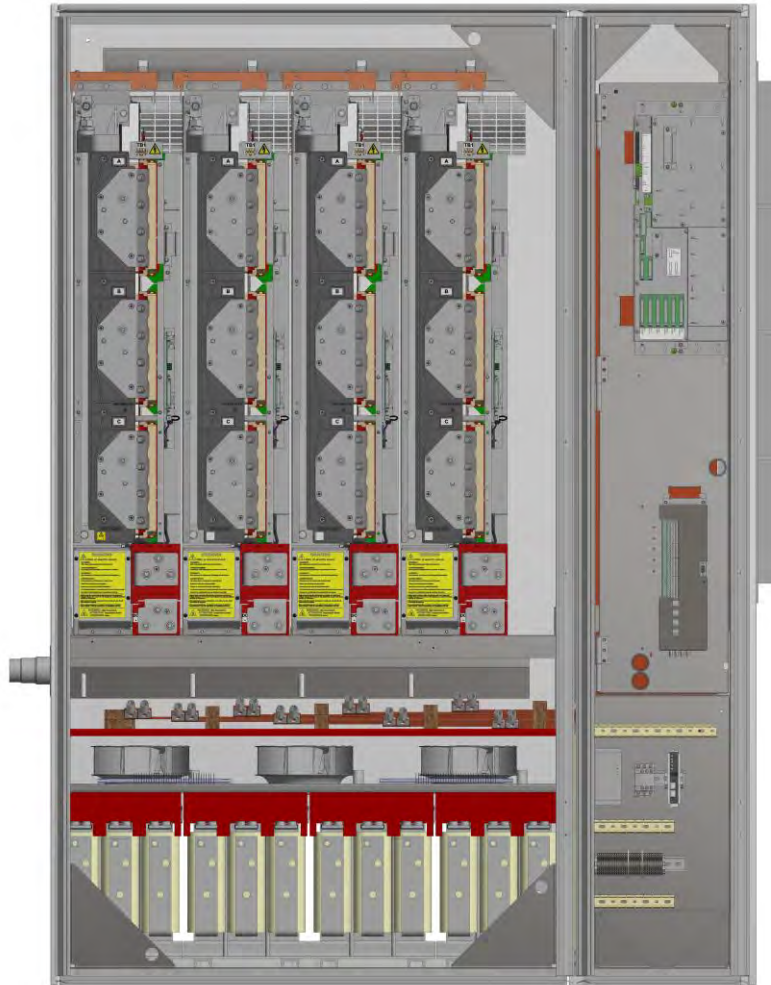

GEN CABINET

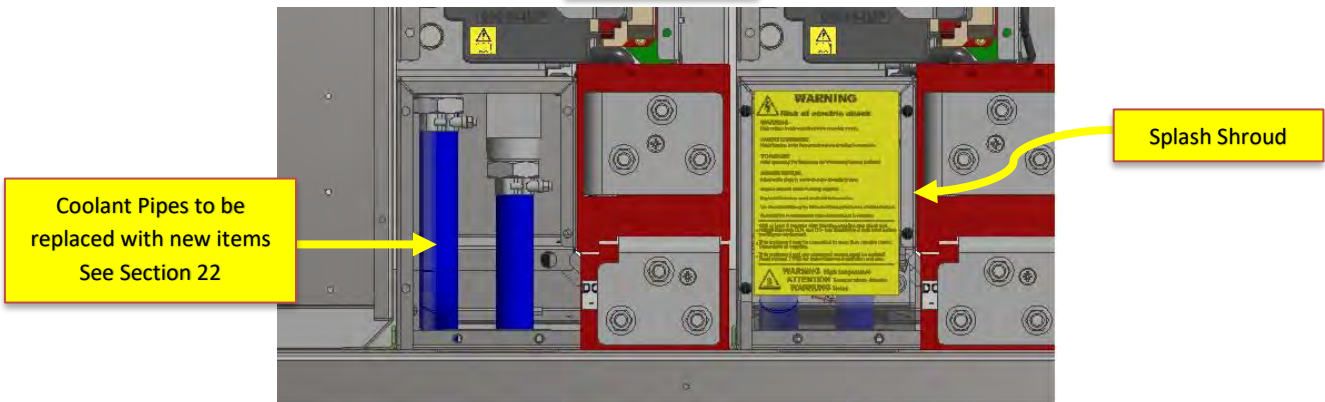

20.7 Remove MVDL1000 DELTA Modules, Replace Hoses, Gen

- Remove all DELTA modules as shown, this will allow access to the lower hoses, as shown below.
- Replace all 8 hoses in each cabinet using those provided in the AEI upgrade kit.

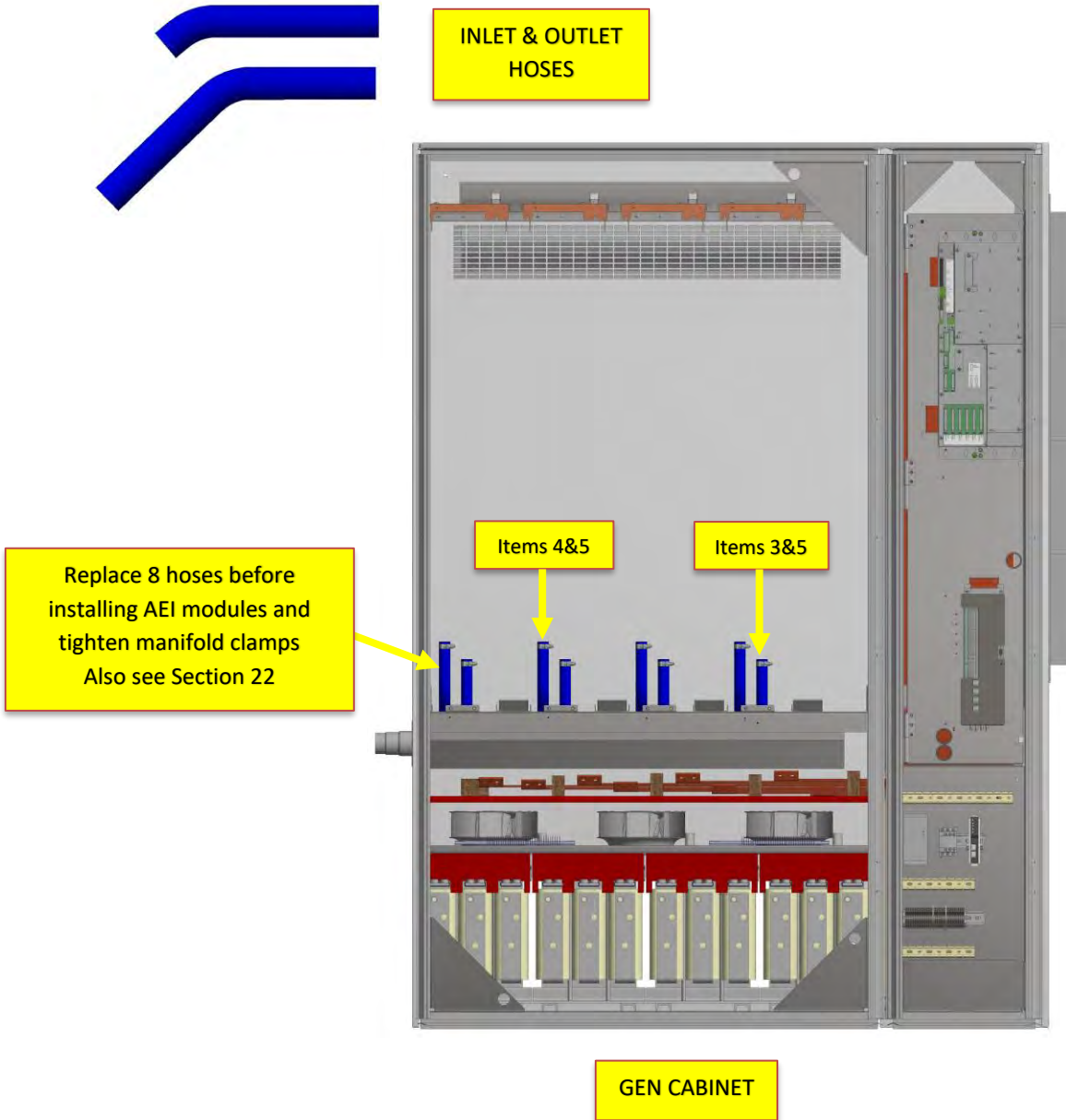

- **IT IS CRITICAL THAT THE HOSES ARE SECURELY INSTALLED AND THE CLAMPS TIGHTENED CORRECTLY. COOLANT LEAKAGE WILL IRREPARABLY DAMAGE THE INVERTER UNITS.**
TIGHTEN CLAMPS TO 4Nm - DO NOT OVERTIGHTEN



21. Install AEI 1000L Modules Gen Cabinet

21.1 Set AEI DIP Switches

- Before the Installation of each AEI verify that DIP switches 1-4 (which configure the overvoltage behavior) on each AEI are set to the equivalent time setting as recorded in Step 20.2 - Master SMPS Jumpers TP10 to TP13

SMPS Jumpers	AEI Switch
TP10	SW1
TP11	SW2
TP12	SW3
TP13	SW4

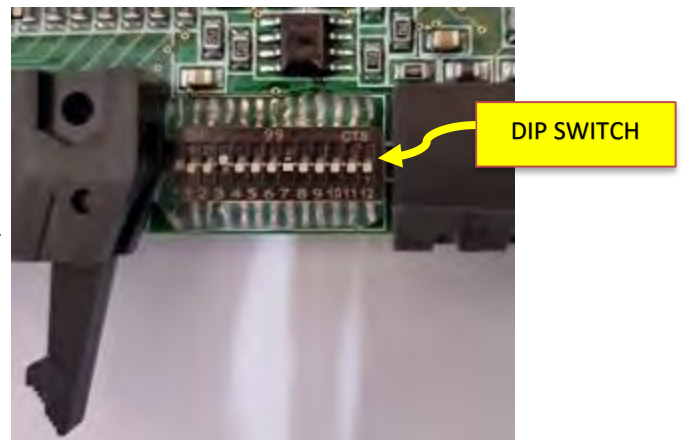
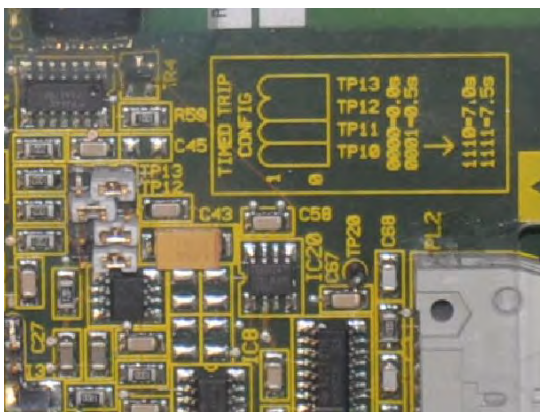

- Before the Installation of each AEI ensure that **Compatibility Rating Mode** is disabled by setting DIP switch SW7 to the **OFF** position.
- **Refer to AVID Document DTS-MID0012 section on User Selectable Options for complete information about these settings.**

THESE SETTINGS ARE IMPORTANT, THE TURBINE WILL NOT RUN CORRECTLY UNLESS THEY ARE MADE.

21.2 Install 4 x AEI 1000L Modules into Generator Cabinet

- GENERATOR side: Fit 4 AEI1000 Modules and secure using fixings shown. Ensure hoses and clamps are installed correctly as detailed in section 22

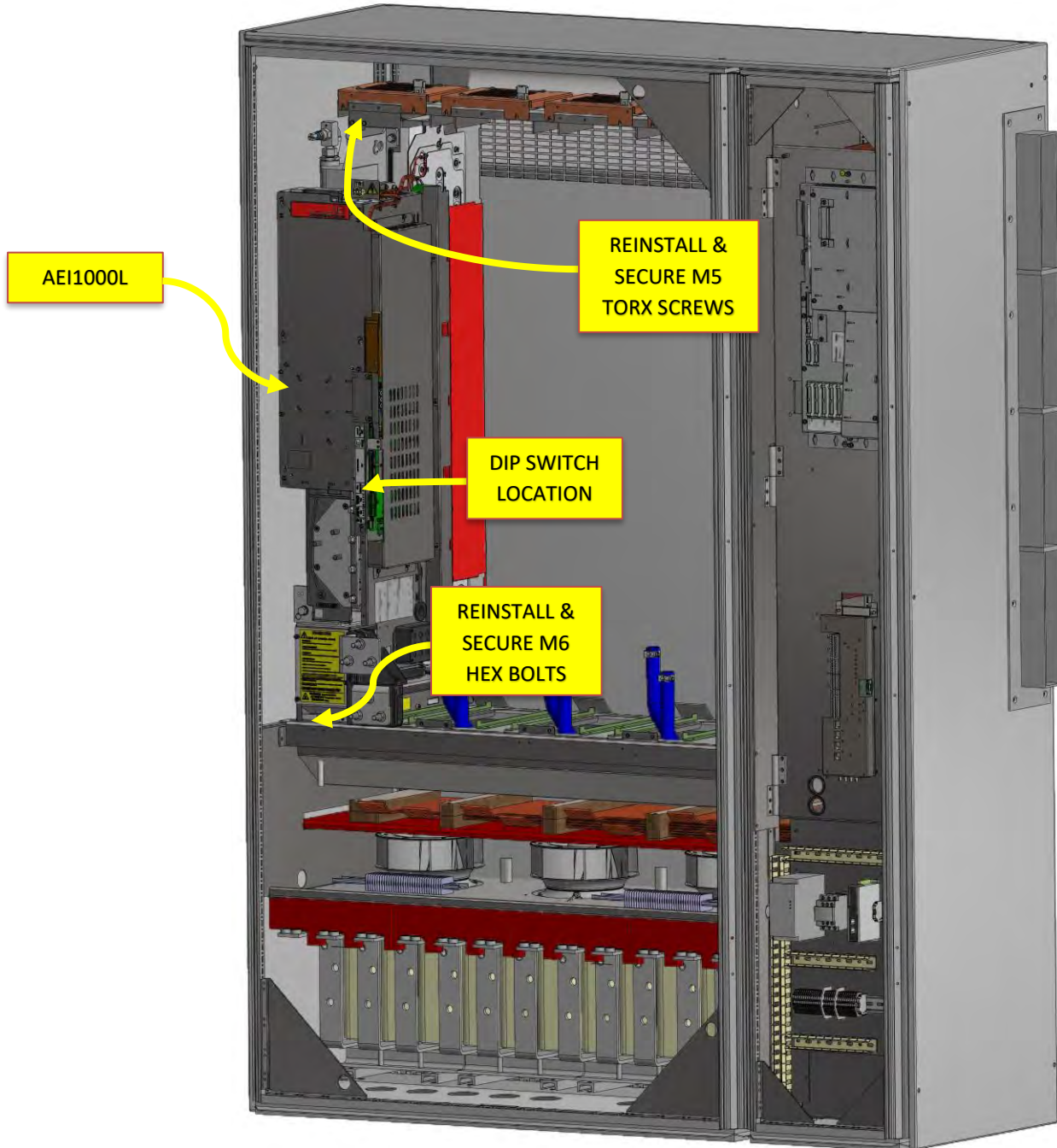

22. Connect Coolant Hoses

- Connect and secure each hose from the inlet manifold to the bottom barbs on all the AEI units.

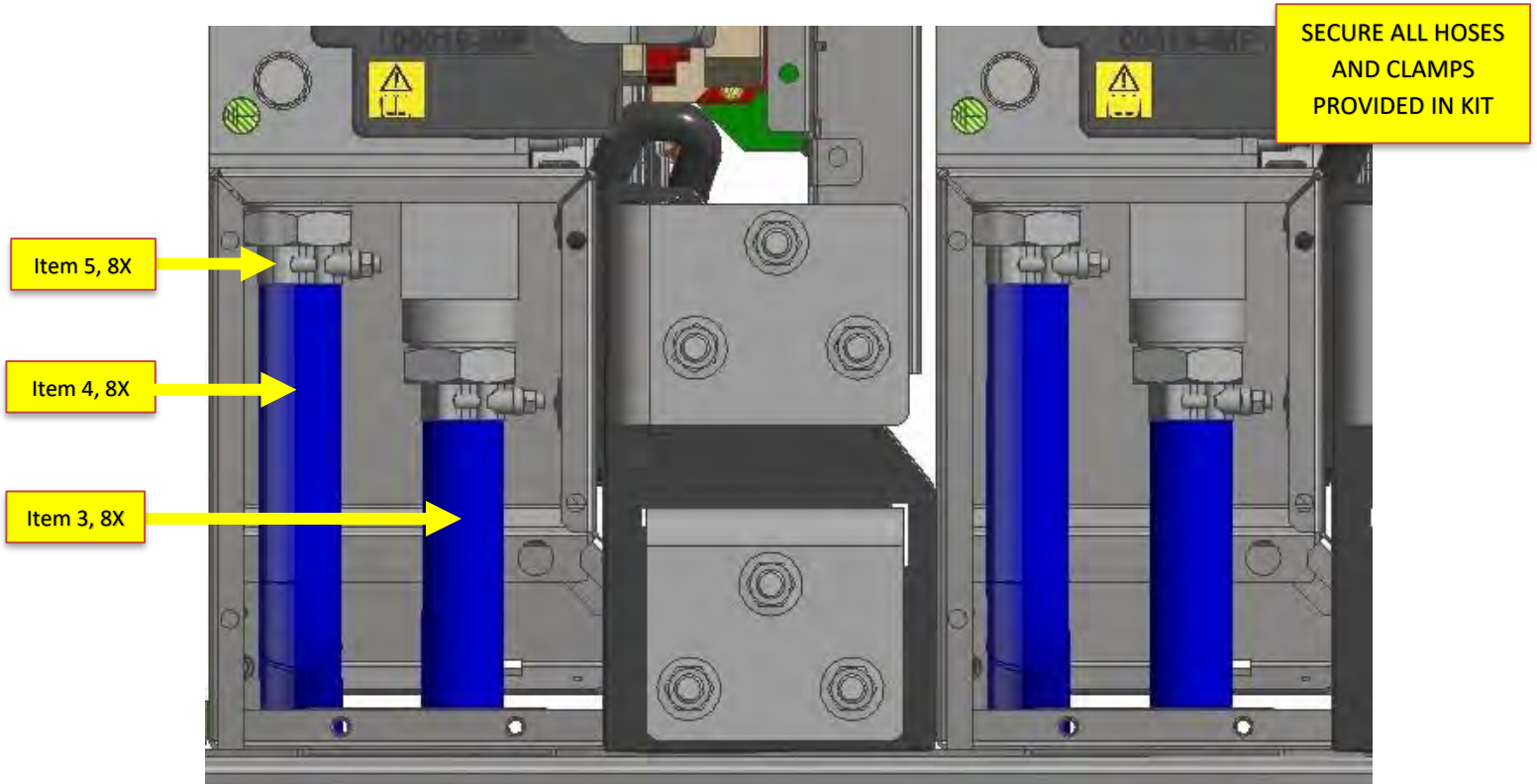

- **IT IS CRITICAL THAT THE HOSES ARE SECURELY INSTALLED AND THE CLAMPS TIGHTENED CORRECTLY. COOLANT LEAKAGE WILL IRREPARABLY DAMAGE THE INVERTER UNITS.**
TIGHTEN CLAMPS TO 4Nm - DO NOT OVERTIGHTEN



- Replace the splash shroud on each AEI



Splash Shroud

23. Reinstall Generator Cubicle AC & DC Cables

- Remove the cover plates from each GEN cubicle AEI.
- Reinstall the GEN cubicle AC & DC cables as identified on removal, using the supplied M10 flange nuts. Torque all connections to 35Nm (310lb.in).

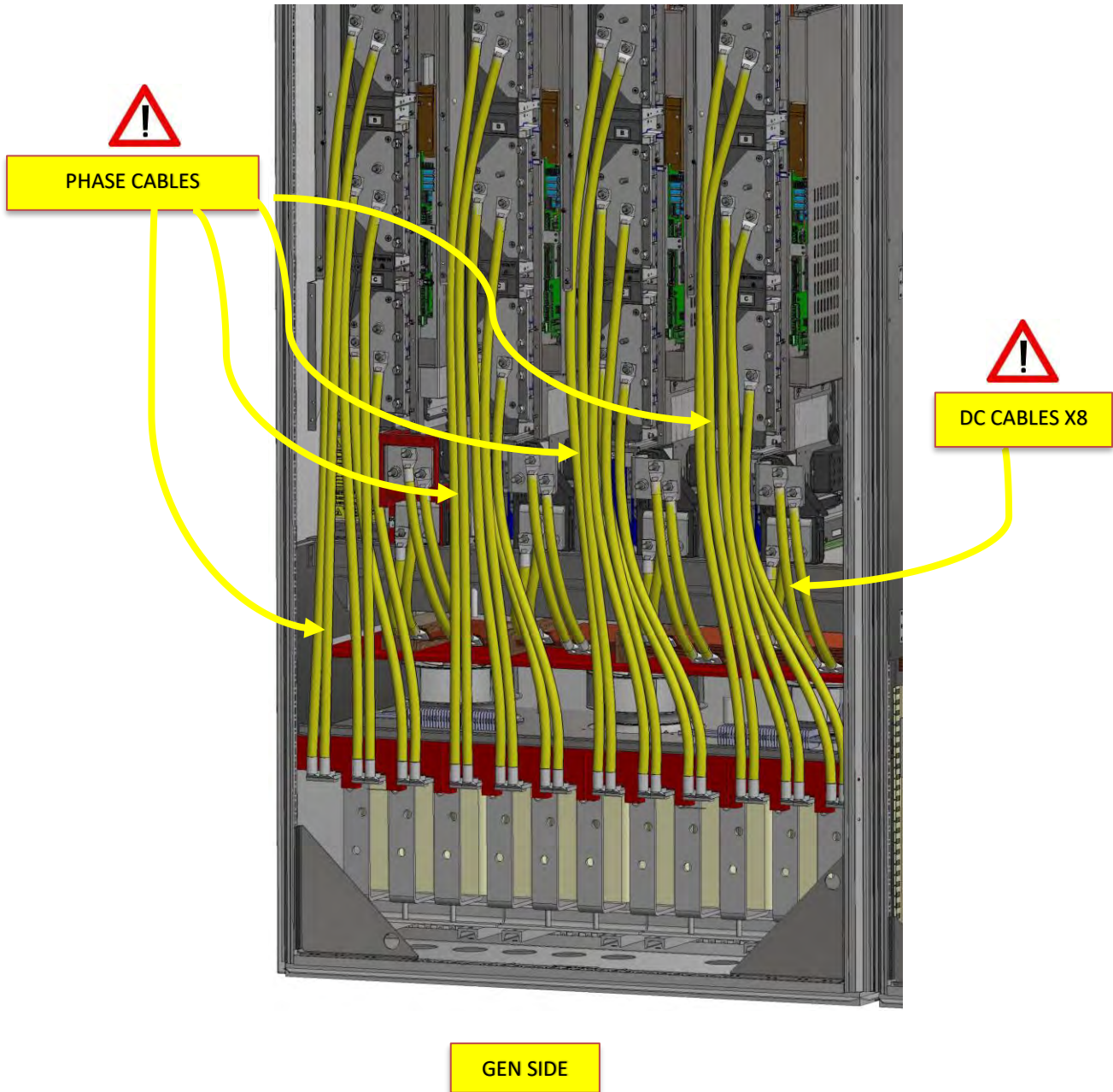

23.1 Reinstall AEI Cover Plates

- Remount the cover plates to each AEI, as shown. Tighten down all M5 Hex Nuts firmly to secure to the AEI
- Remove, flip, and attach the EMC plates to join each adjacent AEI unit, and tighten down firmly with the provided M5 Hex Nuts
- Fit new Bonding bracket (item 2) to side panel and attached to RH Delta in place of EMC plate
- Refit upper left corner strengthening bracket.

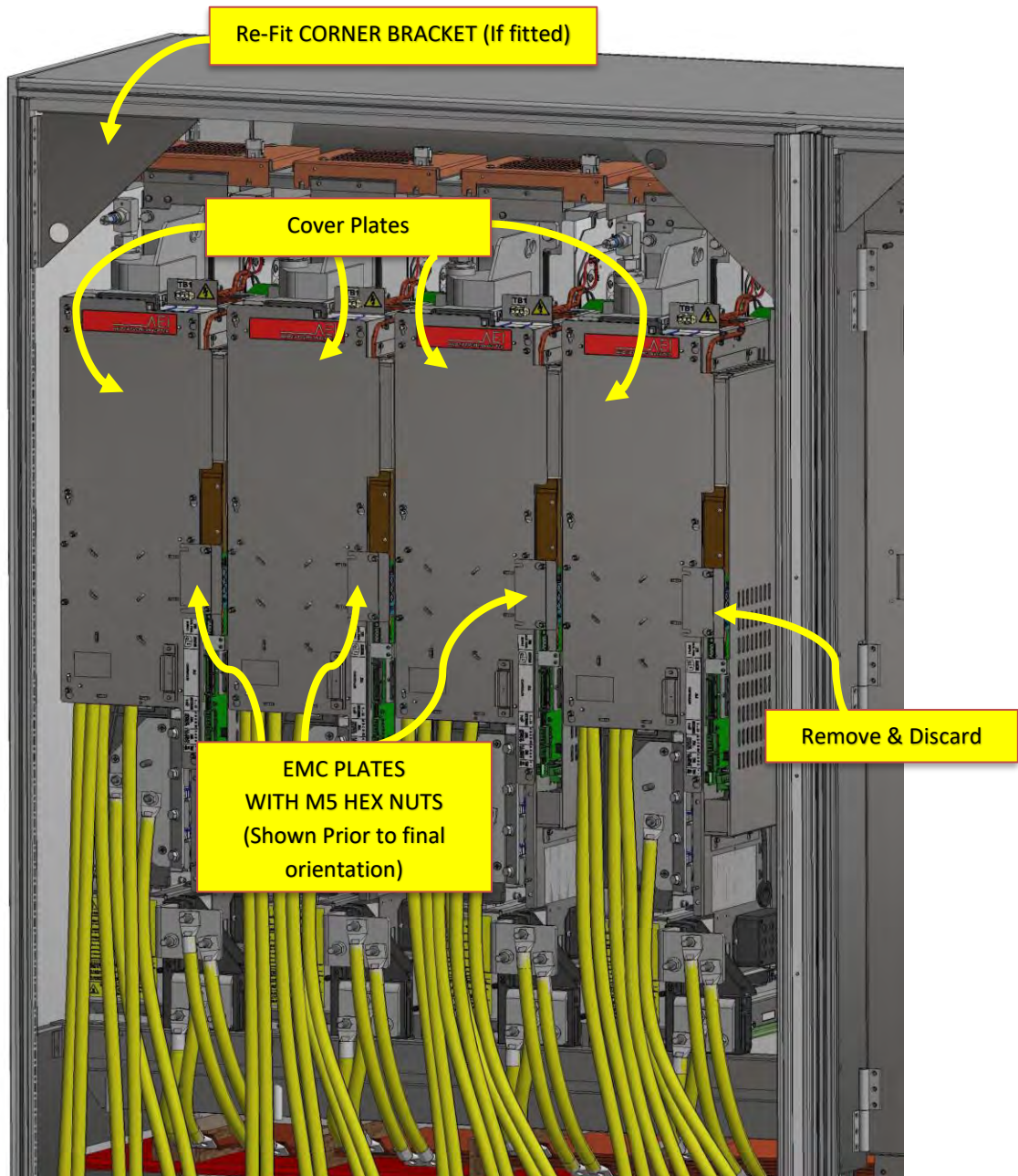

24. Install Ground Brackets and Ribbon Cables

- Install the offset ground bracket (**GEN Item 2**) to allow the routing of the ribbon cables from the GEN control section
- Take care to use the correct bracket for the correct cubicle, this bracket is unique and cannot be interchanged with the bracket for the GRID cubicle.

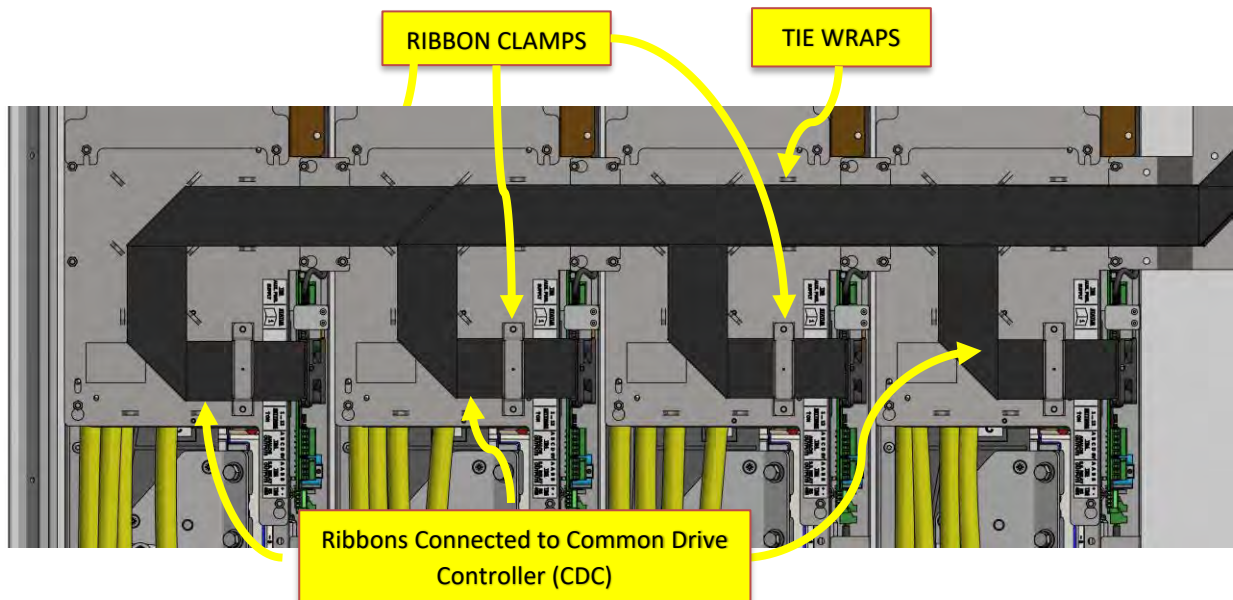
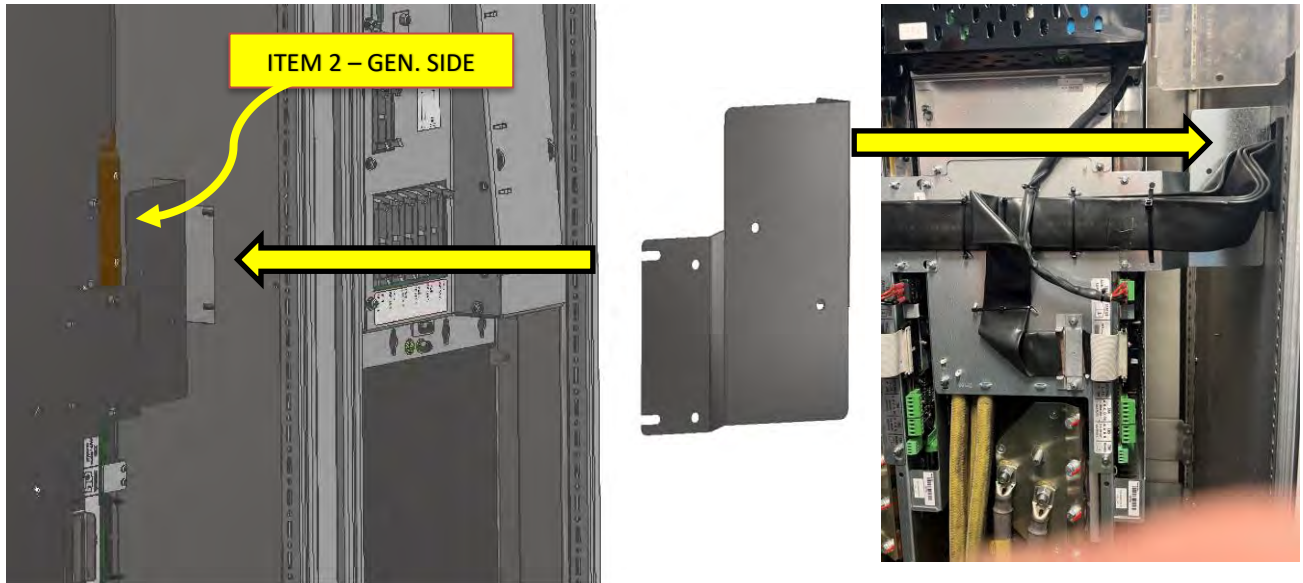

- Feed Ribbon cables through side panel and aperture in hinged gate
- Attach Ribbons to each Delta using cable ties supplied with the kit
- Clamp Ribbons using Ribbon cable clamps on each AEI, Side Panel and Hinged Gate

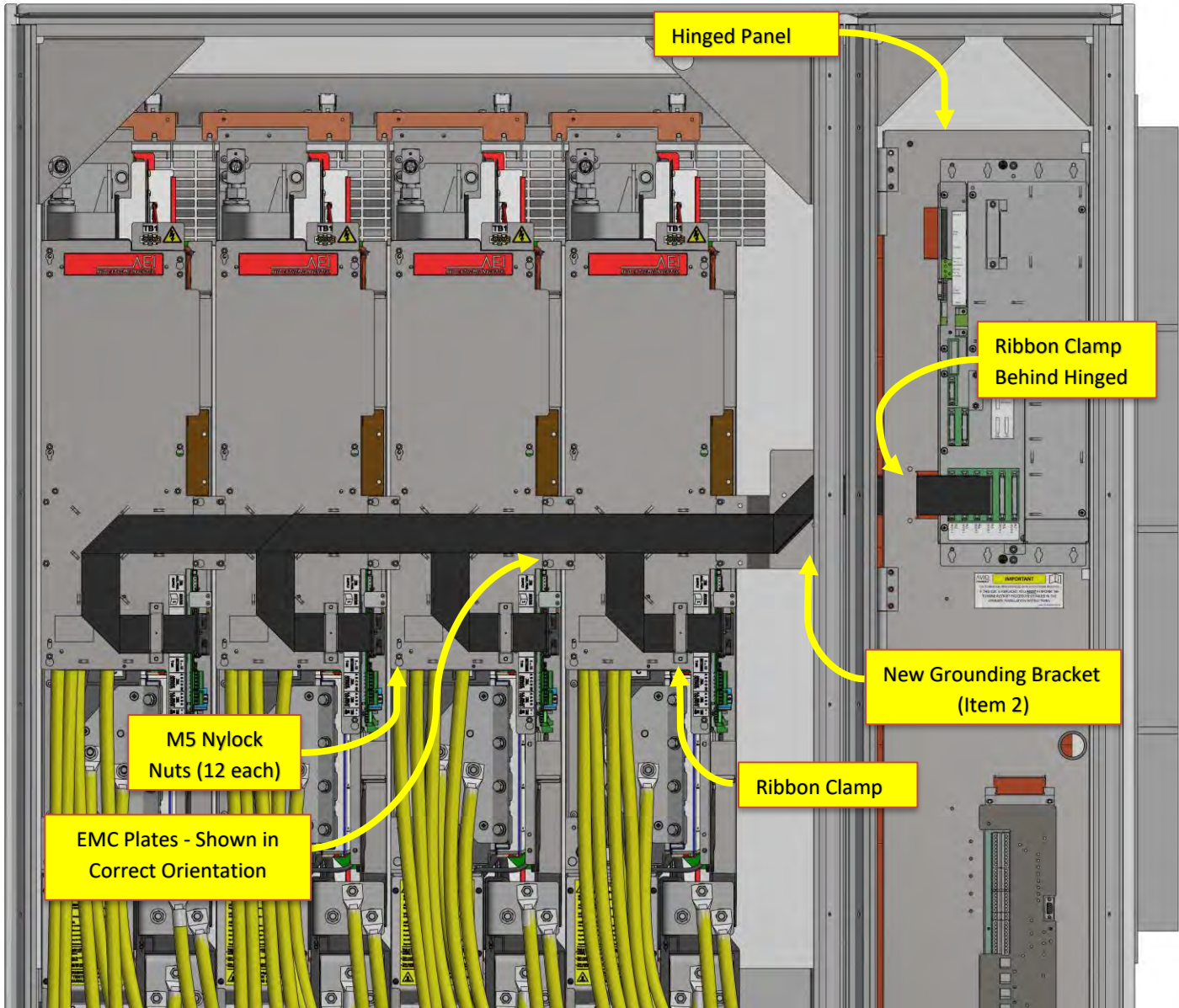

- Connect and clamp down all ribbon cables to each AEI unit and tie wrap into place:

GEN SIDE

25. Install Auxiliary Power Units, Generator Cabinet

- Mount the Auxiliary Power units (**Item 1**) onto the AEI Cover Plates.
- Tighten the Four M5 Nylock nuts securely.

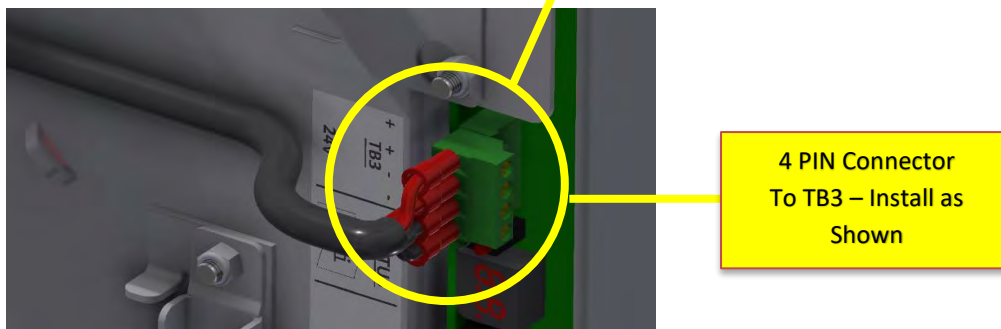
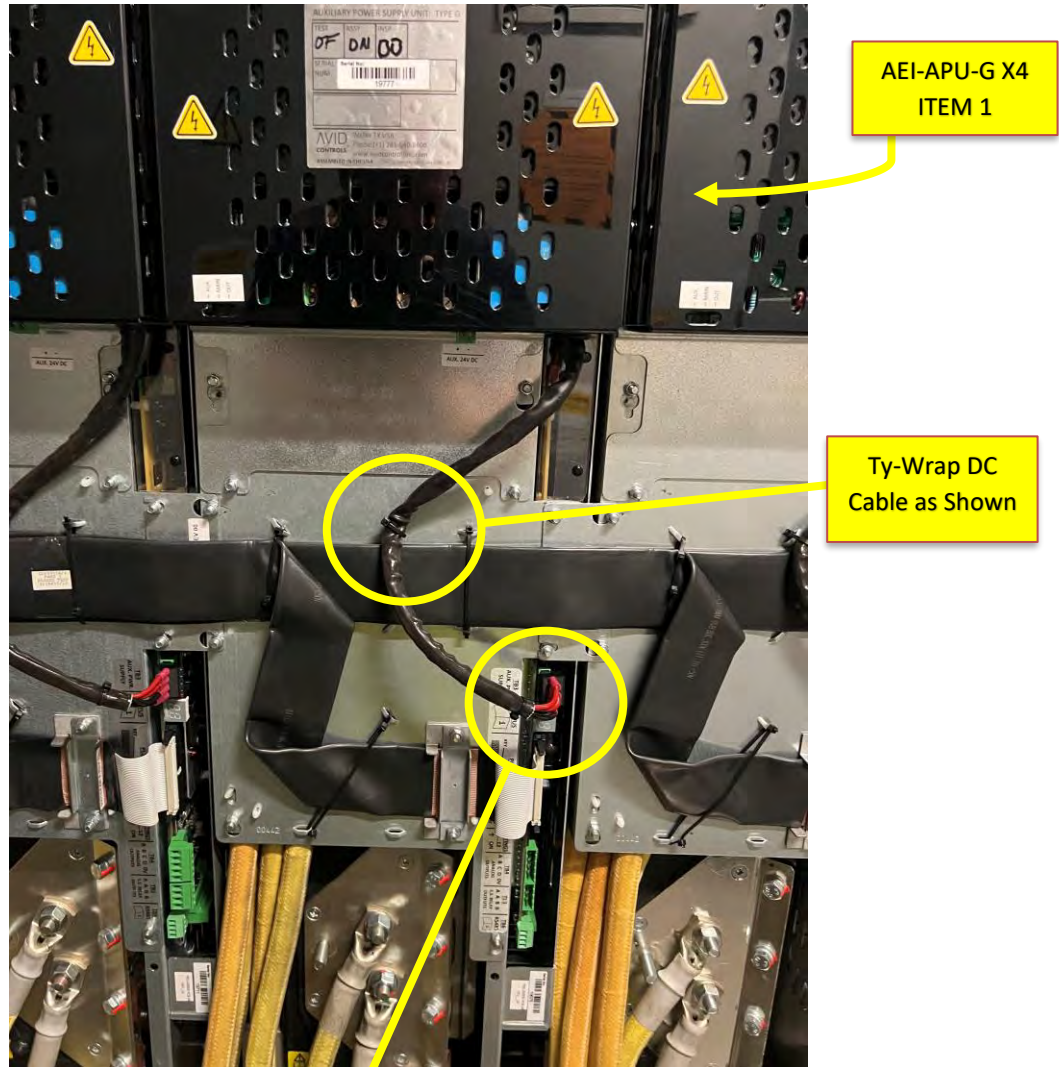



26. Modify GEN Middle Shroud

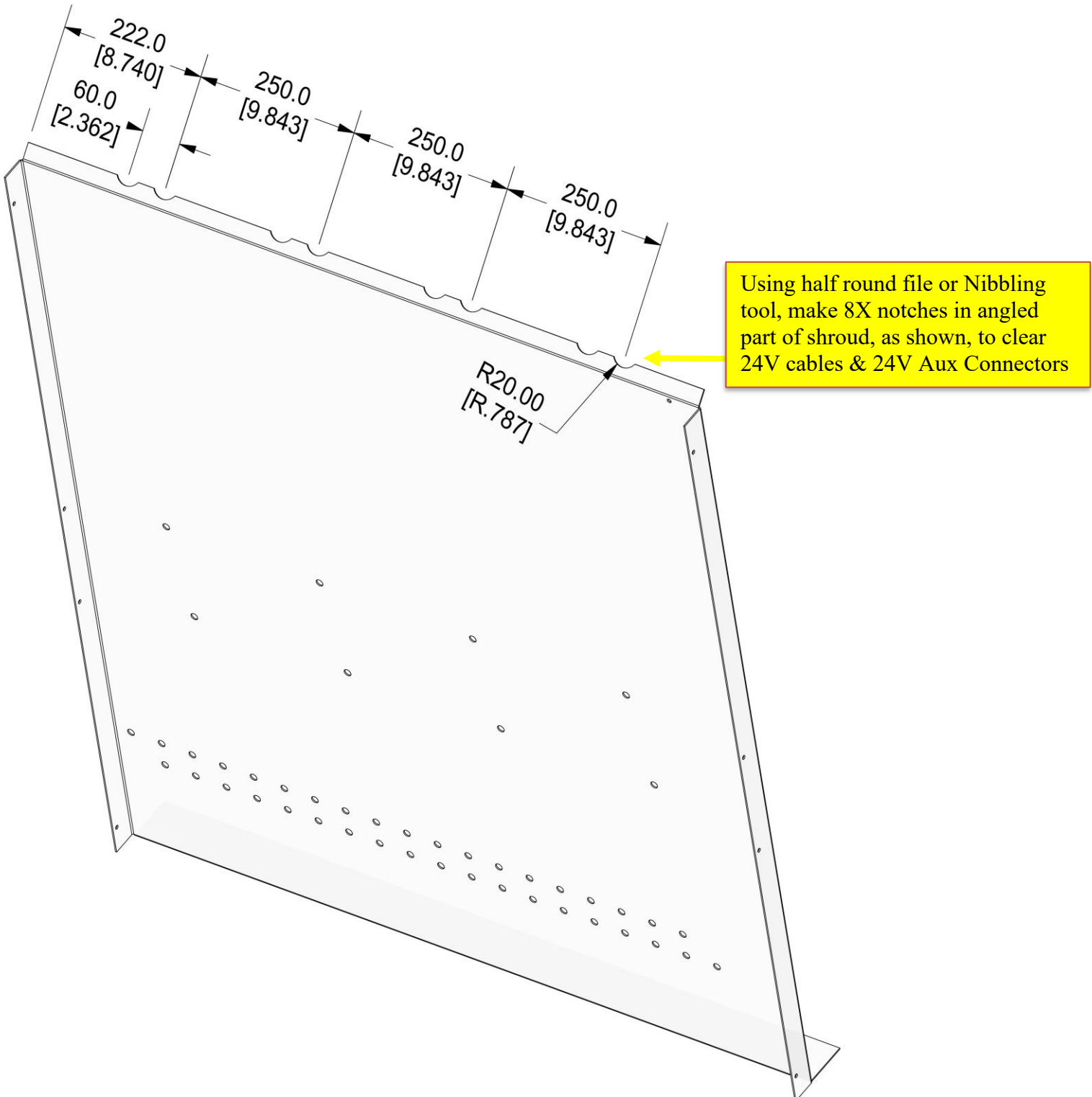

27. Install cubicle shrouds

- Referring to the figure below, re-install the upper left corner bracket, polycarbonate upper, middle & lower cubicle shrouds into the GEN cubicle.

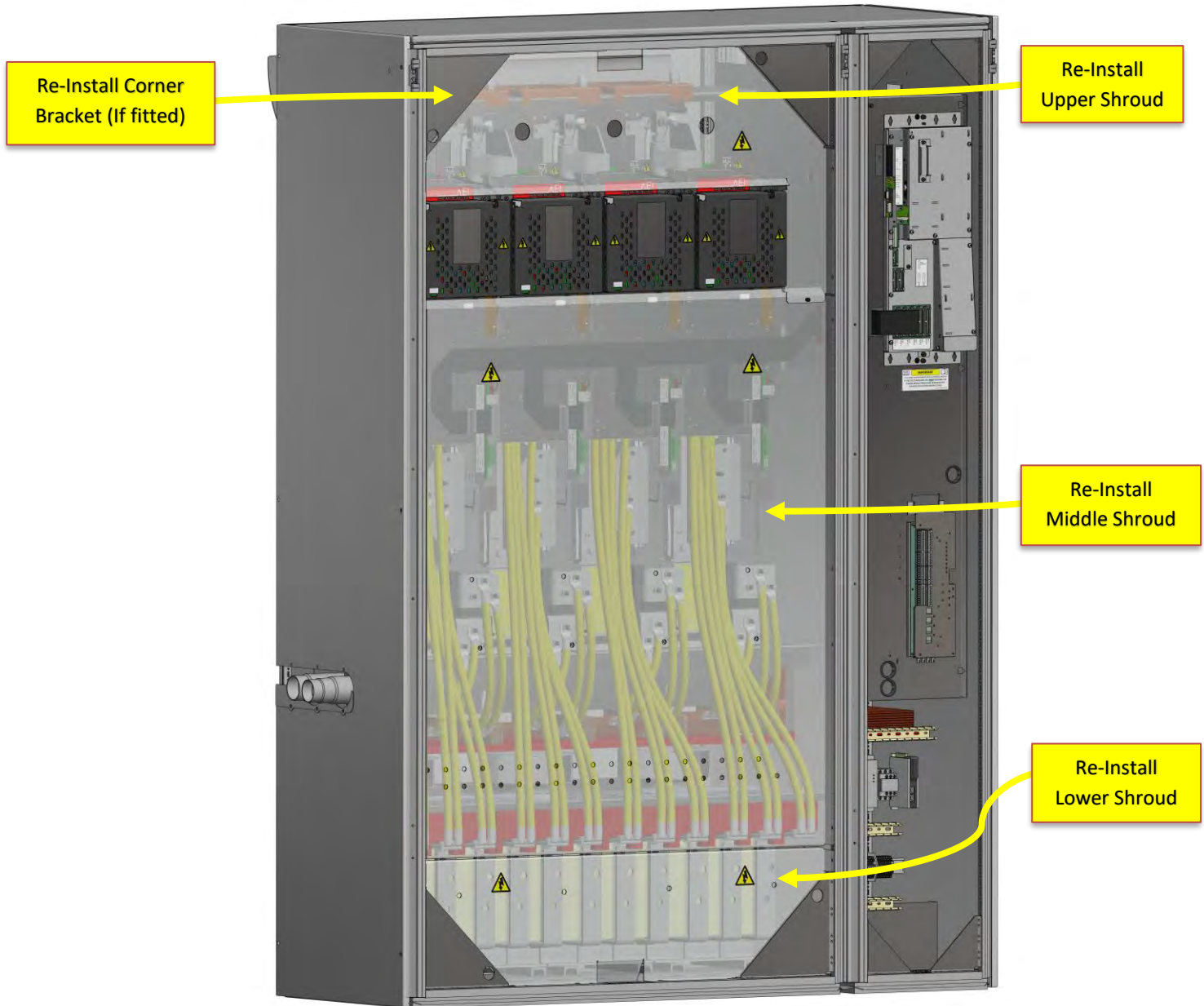

28. Label CDC's – Grid & Gen

- If at any time a CDC module needs to be replaced with either a brand-new unit, or one that has previously operated with Delta modules, ***IT IS CRITICAL THAT THE ABOVE PROCEDURE IS FOLLOWED FOR THE REPLACEMENT CDC.***
- To help ensure this happens, the upgrade kit includes several copies of this label:

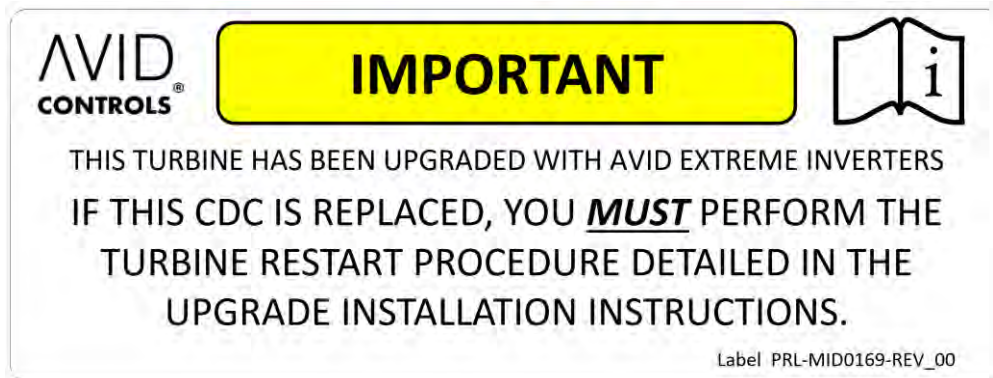

- Which should be attached to BOTH CDCs as shown:

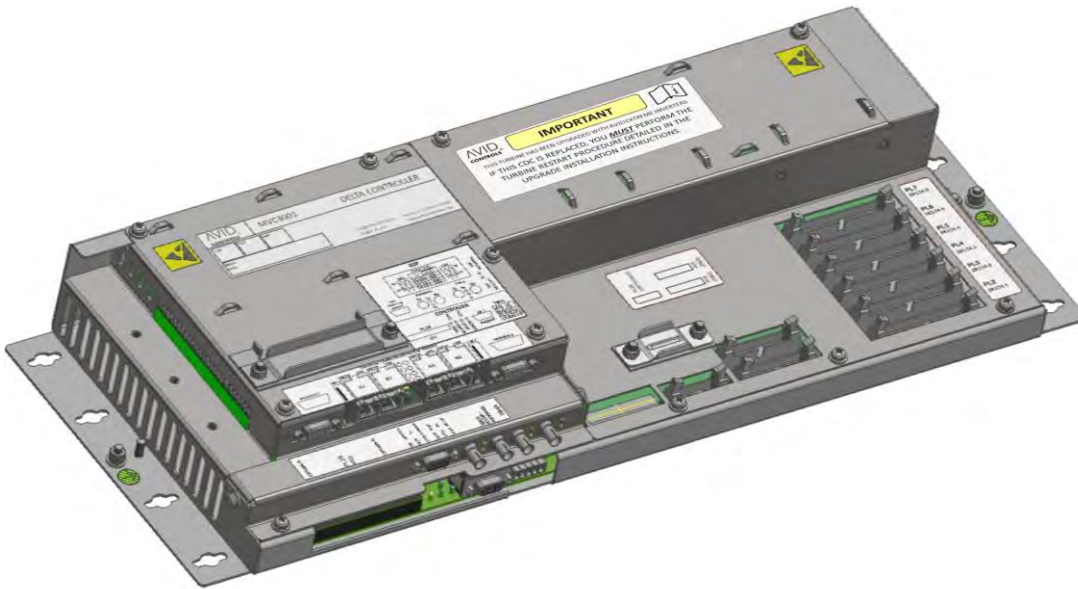

- **Also, temporarily remove the CDCs and attach another copy of this label to the cabinet back-panel underneath the CDC so that it will be visible whenever the CDC is removed.**
- A total of eight copies of this label are provided in the upgrade kit (peelable from a single sheet). Place the sheet with the spare labels into the magnetic envelope provided so that they are available if the CDCs are replaced in the future.

29. Attach Documents for Reference

- Locate the magnetic clear plastic envelope supplied with the upgrade kit.
- Place one copy of the following documents inside:
 - DTS-MID0161 - This Data Sheet
 - DTS-MID0012 - Avid Extreme Inverter Data Sheet
 - DTS-02175-ASY-A - Auxiliary Power Unit – Type G data Sheet
 - PRL-MID0169 - CDC Warning Label (spare copies)
- Attach the envelope to the inside of the control cabinet door:



30. Fit the Upgrade Identification Label

- The upgrade kit includes two weather-proof self-adhesive labels (Item 12) that may be applied to the turbine to clearly indicate that it has been upgraded with Avid Extreme Inverters:



- These may be applied on the interior or exterior of the turbine as-per customer preference (e.g. on the turbine door). See next sheet for suggested location.
- Surface preparation wipes are also included in the kit

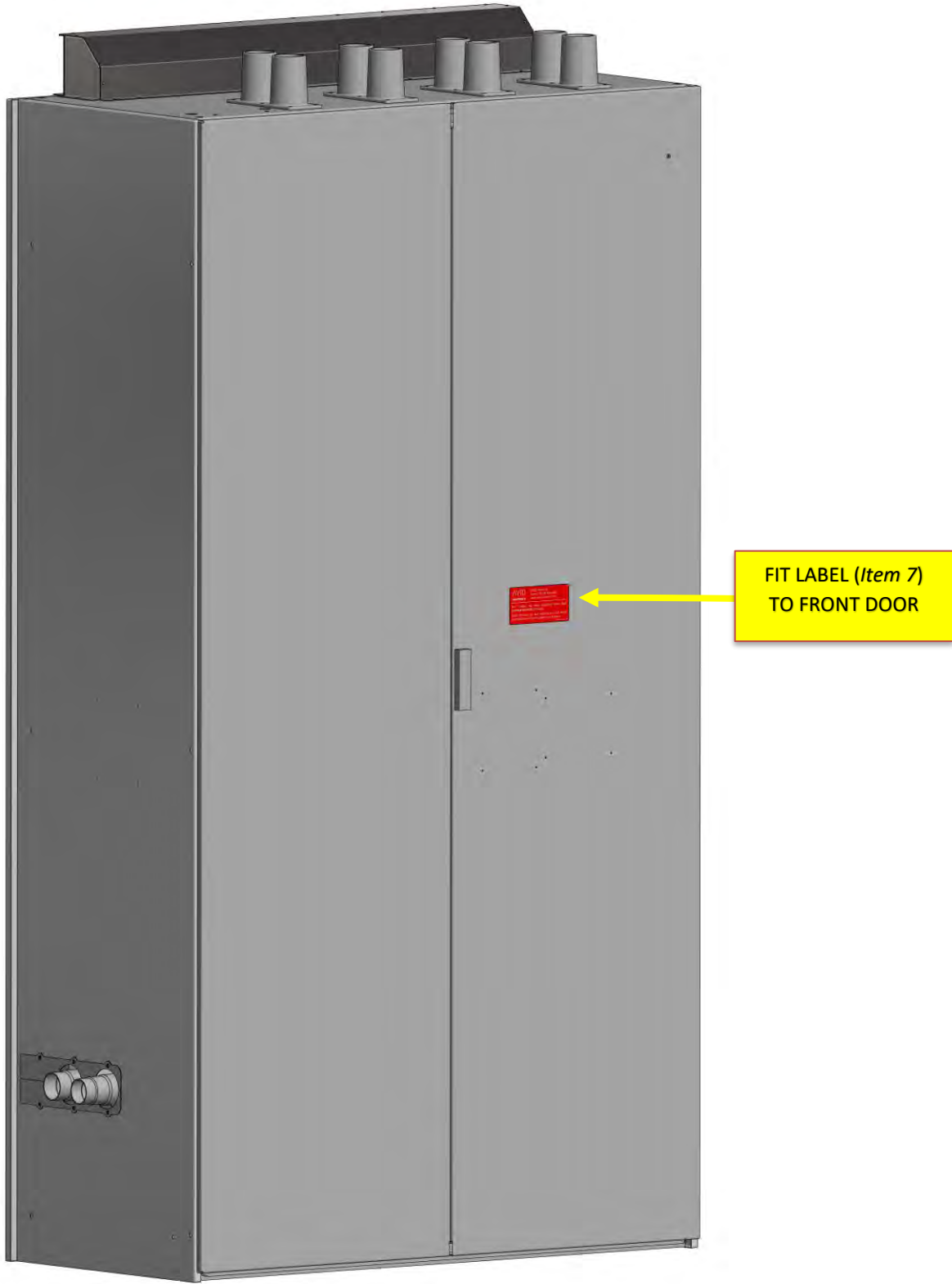

31. Restart Turbine

31.1 Set CDC Parameter P10.36

31.1.1 Background

- When operating with original MVDL1000 units, the CDC controllers are powered by the auxiliary 24V supply before the main DC link is energized (hence the Delta modules are not powered). This means that the CDC cannot identify the Delta modules, leading to faults that interfere with the Siemens control system. To avoid these faults, P10.36 instructs the CDC not to read data from the Deltas but to remember the previously identified values.
- After changing from Deltas to AEIs, it is necessary to perform at least one power cycle with P10.36 set to “Delta Bridge”. This causes the CDC to read the new information from the AEIs. After this has been successfully achieved, P10.36 can be returned to its normal position to avoid the faults prior to charging the DC link.
- It is also necessary to set the active-sharing parameters for the AEI drives to their default values in case they have been changed for the Delta system.
- This procedure will need to be repeated in either the GRID or GENERATOR CDC if replaced at a future date.

31.1.2 Flowchart

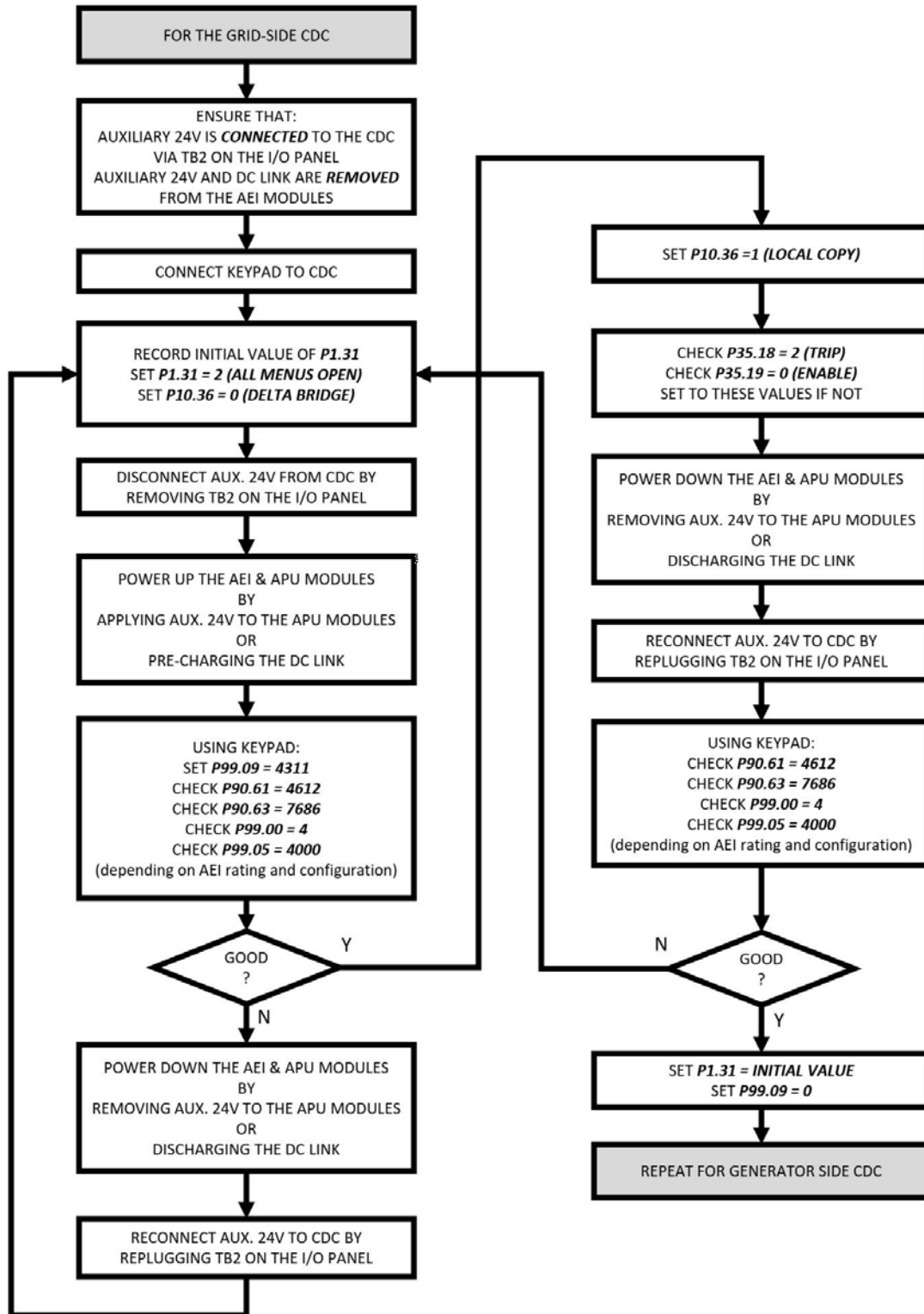

32. Document Revision History

Rev.	Date	Author	Changes
00	Dec 01 2022	M. Cooper	Initial Release
01	Jan 6 2023	M. Cooper	Revised to REV_01 as some REV_00 pre-release copies were circulated
02	Jan 19 2023	M. Cooper	Add items that were missing from material lists. Fix a few style issues.
03	Apr 27 2023	M. Cooper	Minor additions to kit after Orsted install. Minor format changes.
04	Oct 3 2023	M. Cooper	Generator shroud modification added. Note to remove connector plugs added.
05	Dec 12 2023	G. Pace	Added instruction to place label on cabinet back-panel behind the CDCs
06	Feb 13 2024	M. Cooper	Some renumbering of Bill of Material. Steel/Lexan cutter removed from GEN Bill of Material

33. Appendix A – Installation Checklist

Before Going to Turbine

CUSTOMER:		SITE NAME:	
TURBINE NUMBER:		AVID TECHNICIAN (or N/A):	
CUSTOMER LEAD TECHNICIAN:		DATE:	

All Tools Available:

Item	Initial	Item	Initial	Item	Initial
MV3000 Keypad with Cable		Diagonal wire cutters		8mm crescent wrench	
Torx T25 Driver		Phillips #2 x 4" Screwdriver		3/16" x 4" Slotted Screwdriver	
#3 Pozi-drive Screwdriver		Socket Wrench, 3/8" Drive		Torque Wrench, 3/8" Drive	
5mm Socket, 3/8" Drive		8mm Socket, 3/8" Drive		10mm Socket, 3/8" Drive	
17mm Socket, 3/8" Drive		Socket Extension 10" Long, 3/8" Drive		Adjustable Crescent Wrench, 1" Jaw Capacity	
Laptop with Drive Coach and RS232		10" 1/4" Drive Extension [*1]		1/4" Hex to 1/4" Drive Socket Adapter [*1]	
8mm 1/4" Drive Socket [*1]		Digital Voltmeter (DVM)		4 NM Torque Key [*1]	
Hydrometer Kit		AEI/Delta Installation Dolly (if available)		Torque Seal [*1]	
AEI/Delta Lift Hoist (if available)		Sheet Metal Nibbler [*1]			

[*1] : These items are provided as part of the AEI upgrade kit



Avid Extreme Inverter – Turbine Upgrade Installation Instructions, SWP 3.6MW, APU-G

AEI Upgrade Kit Complete

Refer to the upgrade kit parts lists in Sections 7 & 8 of this Data Sheet.

UPGRADE KIT SERIAL NUMBER: _____

Item	Initials
All items in parts list correctly received	

Item	Initials
All documents in document list correctly received	

Turbine History

Was turbine in running condition before AEI upgrade?: _____

If turbine was not in running condition, please attach all available fault history (from SCADA or Drive Coach) and describe all known details of the fault / problem.

Description of attachments:



At Turbine, Before Removing Deltas

CUSTOMER:		SITE NAME:	
TURBINE NUMBER:		AVID TECHNICIAN (or N/A):	
CUSTOMER LEAD TECHNICIAN:		DATE:	

Status of Turbine:

Turbine Faults (if applicable)
(blown fuses, tripped breakers, system fault codes etc.):

Visible Damage (Before Removing Deltas)
(Damaged cables or ribbons, missing hardware, coolant leaks etc.) :

Check coolant with hydrometer and record result
If out of specification, coolant must be replaced before installation of AEI units:

Hydrometer Reading: _____ Units: _____ In Spec ? : _____

Customer Lock-out Tag-Out _____ System safe voltage checks
Procedures complete: _____ AC & DC complete: _____

Position of all cables, ribbons, tie-wraps etc. recorded: _____

Identify and record GEN side master SMPS jumper settings (jumper 10-13) and record below:

Jumper 10: _____ Jumper 11: _____ Jumper 12: _____ Jumper 13: _____

Identify and record GRID side master SMPS jumper settings (jumper 10-13) and record below:

Jumper 10: _____ Jumper 11: _____ Jumper 12: _____ Jumper 13: _____

After Installation, Before Power-On

CUSTOMER:		SITE NAME:	
TURBINE NUMBER:		AVID TECHNICIAN (or N/A):	
CUSTOMER LEAD TECHNICIAN:		DATE:	

CHECK ITEM	Grid Position 1	Grid Position 2	Grid Position 3	Grid Position 4
AEI Serial #				
APU Serial #				
DIP Switches ON (circle those that are ON)	1 2 3 4 5 6 7 8 9 10 11 12	1 2 3 4 5 6 7 8 9 10 11 12	1 2 3 4 5 6 7 8 9 10 11 12	1 2 3 4 5 6 7 8 9 10 11 12
Power Terminal Torque set to 35Nm and sealed	Aph #1			
	Aph #2			
	Bph #1			
	Bph #2			
	Cph #1			
	Cph #2			
	DC+ #1			
	DC+ #2			
	DC- #1			
DC- #2				
Pull-test control wires				
DC fuses replaced				
Ribbon clamps secure and not damaging insulation				
Coolant hoses torqued to 4 Nm using torque-key				
All wires/cables correctly tie-wrapped				

CUSTOMER:		SITE NAME:	
TURBINE NUMBER:		AVID TECHNICIAN (or N/A):	
CUSTOMER LEAD TECHNICIAN:		DATE:	

CHECK ITEM	Gen Position 1	Gen Position 2	Gen Position 3	Gen Position 4
AEI Serial #				
APU Serial #				
DIP Switches ON (circle those that are ON)	1 2 3 4 5 6 7 8 9 10 11 12	1 2 3 4 5 6 7 8 9 10 11 12	1 2 3 4 5 6 7 8 9 10 11 12	1 2 3 4 5 6 7 8 9 10 11 12
Power Terminal Torque set to 35Nm and sealed	Aph #1			
	Aph #2			
	Bph #1			
	Bph #2			
	Cph #1			
	Cph #2			
	DC+ #1			
	DC+ #2			
	DC- #1			
DC- #2				
Pull-test control wires				
DC Fuses Replaced				
Ribbon clamps secure and not damaging insulation				
Coolant hoses torqued to 4 Nm using torque- key				
All wires/cables correctly tie-wrapped				

Turbine Restart Checklist

CUSTOMER:		SITE NAME:	
TURBINE NUMBER:		AVID TECHNICIAN (or N/A):	
CUSTOMER LEAD TECHNICIAN:		DATE:	

All air purged from cooling system: _____ No coolant leaks detected: _____

Check and record the final values of the following parameters etc. for both GEN and GRID CDC:

Parameter Etc.	Expected Value	GEN Value	GRID Value	Notes
P99.00	4			
P99.05	4000			
P10.36	1			
P35.18	1			
P99.09	0			Return to zero <i>after</i> restart procedure
P1.32	Customer Preference			Return to its original value <i>after</i> restart procedure
CDC Part Number				
CDC LED Shape	Round or Square [R/S]			
CDC Firmware Version				
Parameter Set File				



Avid Extreme Inverter – Turbine Upgrade Installation Instructions, SWP 3.6MW, APU-G

List and Describe any Faults During Re-Start:

Confirm document envelope and all contents (see section 29) installed in cabinet: _____

Record the 2-digit display readouts on each AEI:

GEN #1: _____ GEN #2: _____

GEN #3: _____ GEN #4: _____

GRID #1: _____ GRID #2: _____

GRID #3: _____ GRID #4: _____

Additional Information:

Torque Records

Installation Date: _____

Turbine Identifier: _____

Technicians: _____

Fastener Torques:

Item	Fastener Type	Number Fasteners	Set Torque	Tool Used Identifier	Tech. Initials
AEI Module DC Fishplate (Section 16.1)	M10	4	35Nm		
Hose Clips GRID (Section 8)	M5	8	4Nm		
Hose Clips GENERATOR (Section 21)	M5	8	4Nm		
DC Cables to Upper Fishplate (section 11)	M10	16	35Nm		
Grid AC Cables (section 12)	M10	48	35Nm		
Gen AC & DC cables (Section 21)	M10	80	35Nm		

Additional Notes: