

REV: 01
August 15, 2024

Avid Controls Inc.
41261 Park 290 Drive, Waller, TX 77484, USA
info@avidcontrolsinc.com
(+1) (281) 640-8600

AVID Controls Inc. pursues a policy of continuous product improvement and innovation. This may not be the latest revision of this publication and may not reflect all current product changes. Contact AVID Controls Inc. for the latest revision of this data sheet and information on other product enhancements.

INTENTIONALLY BLANK

Contents

- 1. Introduction 4
- 2. WARNINGS 4
- 3. Specification..... 5
 - 3.1 Model Numbers 5
 - 3.2 Electrical – Power Section..... 6
 - 3.3 Electrical – Control & Interface Section..... 7
 - 3.4 Cooling 8
 - 3.5 Sharing Reactors..... 8
 - 3.6 Environmental 9
 - 3.7 Electrical Supply..... 10
 - 3.8 Mechanical..... 11
- 4. High Voltage / Power Connections 12
- 5. Low Voltage / Control Connections..... 12
 - 5.1 Overview 12
 - 5.2 TB3 – Auxiliary Power Supply 13
 - 5.3 TB4 – Analog Outputs..... 14
 - 5.4 TB5 – Solid State Relays..... 15
 - 5.5 TB6 – RS485 15
 - 5.6 PL2 – Controller Connection..... 15
- 6. User Selectable Options 16
 - 6.1 Overview 16
 - 6.2 Over-volts Trip Mode (SW1 to SW4) 16
 - 6.3 Analog Output Mode (SW5 and SW6)..... 17
 - 6.4 Compatibility Rating Mode (SW7)..... 18
 - 6.5 MODBUS Address Setup Switches (SW8 to SW10)..... 18
 - 6.6 Unused Switches (SW11 to SW12)..... 19
- 7. LED’s and Fault Indication 19
 - 7.1 Discrete LED’s 19
 - 7.2 Program Version Display 19
 - 7.3 LED Feedback Indication 20
 - 7.4 Fault Codes 21
- 8. MODBUS Communications..... 23
 - 8.1 Introduction 23
 - 8.2 MODBUS_TIMER..... 23
 - 8.3 Diagnostic Data 23
- 9. System Design Requirements to Satisfy UL508C..... 26
 - 9.1 EMC Bonding for Electromagnetic Compatibility 26
 - 9.2 Enclosure 27
 - 9.2.1 Enclosure Requirements 27
 - 9.2.2 AEI Module Construction..... 27
 - 9.2.3 Enclosure Construction Requirements..... 27
- 10. Spares and Service 28
- 11. Document Revision History..... 28

AVID CONTROLS and the  logo are registered trademarks of Avid Controls Inc.

MODBUS is a registered trademark of Schneider Automation Inc.

1. Introduction

- The AEI550A inverter modules are high reliability air cooled inverter modules with nominal ratings of 550A at 690Vac for use with MV3000 AC drives, controlled by the Common Drive Controller (CDC).
- Its significant technical attributes are:
 - Sintered solder-free IGBT modules for extended life operation
 - Ruggedized IGBT die for improved environmental robustness
 - Reduced internal voltage overshoot
 - More robust, fully digital gate driver
 - IGBT modules are fully sealed for protection from condensation
 - Continuous, accurate monitoring of IGBT silicon temperature under all operating conditions

2. WARNINGS

- This equipment may be connected to more than one live circuit.
- Wait at least 5 minutes after isolating supplies and check that the voltage between DC+ and DC- has reduced to a safe level before working on the equipment.
- Surfaces can reach high temperatures and remain hot for some time after power is removed.
- Unit is heavy: 71kg (156 lb.) so use safe lifting and handling methods
- This equipment or any part of the equipment should be disposed of in accordance with the laws of the country of use.
- Modern high technology materials have been used in the manufacture of the equipment to ensure optimum performance. Care has been taken with the selection of these materials to minimize risks to health and safety. However, some materials require special consideration during disposal.
- In common with all products of this type, the high voltage electrolytic capacitors contain an electrolyte, which must be disposed of as hazardous waste. The electrolytes are solutions of organic and/or boric acid. The major solvents in the capacitors are butyrolactone and ethylene glycol. The electrolyte is non-carcinogenic but may cause irritation to the skin if contact is prolonged.

3. Specification

3.1 Model Numbers

- All Avid Extreme Inverter products use a consistent Model Number scheme:

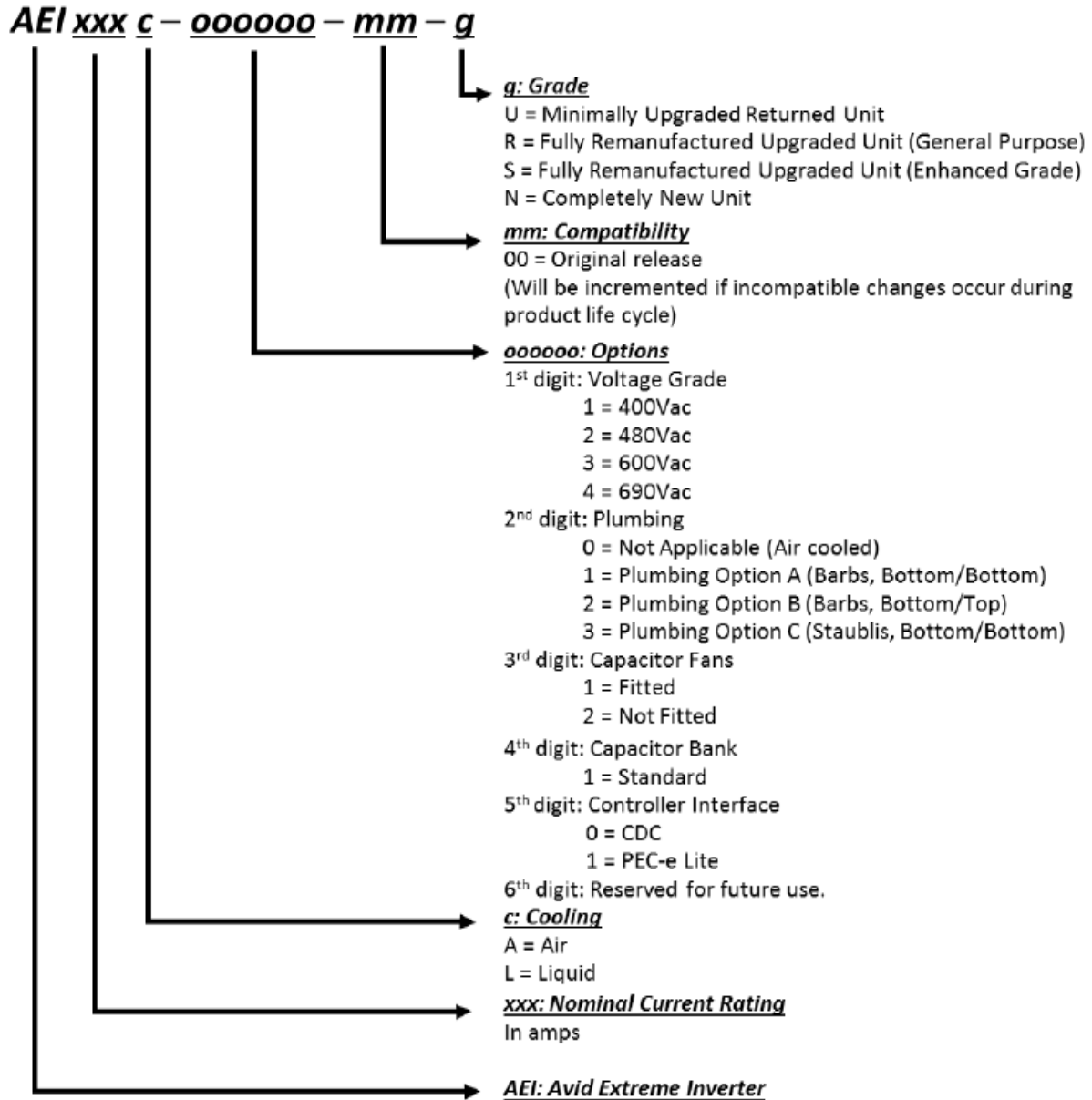

3.2 Electrical – Power Section

Specification	<i>AEI550A</i>	Notes & Applicable Conditions
Continuous Current, 690V	550A	High Capacity fan required – see section 3.4 for details 60s Overload = 150% once per 10 minutes DC Link Voltage = 1100V PWM Frequency = 2.5 kHz
Continuous DC Link Operating Voltage	1188 V	
Short Term (7.5s) DC Link Operating Voltage	1262 V	
Non-Operating DC Link Withstand Voltage	1350 V	
DC Link Capacitance	7833 μ F	+20/-10 %
Maximum PWM Frequency	2.5 kHz	In some circumstances, higher frequencies may be used with de-rating – contact Avid Controls if this is required.

3.3 Electrical – Control & Interface Section

Specification	<i>AEI550A</i>	Notes
Control Power Source	Avid Auxiliary Power Unit (APU) Model Numbers: AEI-APU-B	Customers wishing to provide their own auxiliary power must contact Avid Controls for further information. Use of a non-approved power supply will void the product warranty.
Analog Outputs	4 Channels +/-10V	Optional indication for phase currents, temperatures etc. DIP switch function selection See section 6.3 for more details
Fault Indication	<ul style="list-style-type: none"> Fault Codes indicated by controller for all compatible faults Two-digit LED display for additional diagnostic codes Two 24V Solid-State relay outputs for indication of fault status 	See section 7.4 for definition of fault codes.
Operational Indication	Two-digit LED display for display of DC link voltage, currents and temperatures	See section 7.3 for details.
Remote Monitoring	Two wire RS485 (non-isolated) MODBUS RTU Protocol	See section 8 for details.
DC Link Voltage Feedback Accuracy	+/- 4V @ 1000V DC	Measured internally within unit

3.4 Cooling

- A cooling fan is required for each AEI module.
- Two models of fan are available.
 - MVC3014-4001-A High Capacity Fan, 230V single phase
 - LSR31V6900/10 High Capacity, 600V, 3-phase (not for sale in EU or UK)
- Refer to Avid Controls for Data Sheets on these fans

3.5 Sharing Reactors

- To ensure current sharing between multiple AEI transistor modules, sharing reactors are required.

Reactor Number	Style	Mounting	Inductance per Phase	Weight
50Z0126/01	Air Cored	Floor	0.01mH	30kg/ 66 lbs.

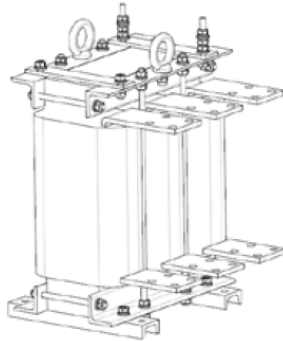

3.6 Environmental

Function	Specification				
Operating Ambient Temperature	0 to 50°C (32°F to 122°F) Note: If clean/dirty air is segregated, the control electronics and fan transformers can withstand 60°C (140°F). Open Type assembly (UL 508C): Maximum surrounding air temperature 60°C				
Operating Relative Humidity	5 to 95% (non-condensing)				
Operating Altitude	Normal operating altitude up to 1000 m (3280 ft.) above sea level. From 1000 m (3280 ft.) to a maximum of 2000 m (6551 ft.) de-rate by 7.3% per 1000 m (3280 ft.).				
Operating Cooling air	Pollution Degree 2 (IEC 60664-1, UL 840 and CSA C22.2 No. 0.2-93) i.e. clean, free from dust, condensation and conductive or corrosive gases. If conductive pollution or condensation are expected (Pollution Degree 3), the drive must be placed in an enclosure which achieves Pollution Degree 2 by: - excluding the conductive pollution e.g. by the use of filtered air; - preventing condensation e.g. by use of anti-condensation heaters. In extreme environments dual circuit heat exchangers are recommended.				
Operating and Storage Chemicals (max.)	15 ppm H ₂ S 25 ppm NO ₂ 25 ppm SO ₂				
Storage Temperature	-25 to +55°C (-13°F to 131°F)				
Storage Relative Humidity	5 to 95% non-condensing				
Storage Altitude	Up to 3000 m (9842 ft.) above sea level				
Transport Temperature	-25 to +70°C (-13°F to 158°F)				
Transport Relative Humidity	5 to 95% (non-condensing)				
Transport Altitude	Will withstand air transport				
Enclosure Ingress Protection	IP00 (to IEC 60529; BS EN 60529), Open Type product (to UL508C, IEC 618005-1) These modules must always be installed in an appropriate enclosure with restricted access.				
Vibration - Operational	Type tested against the worst combination of the requirements of IEC 61800-2 (which specifies 'Class 3M1' of IEC 60721-3-3), EN 50178, IEC 61800-5-1 and DNV Rules for Ships, Jan. 2010 Part 4, Ch. 8, Section 3; summarized by the 'composite' column below:				
	Frequency	IEC 61800-2	IEC 81800-5-1 EN 50178	DNV	Composite
	2 to 5 Hz	0.3 mm amplitude			0.3 mm amplitude
	5 to 9 Hz	0.3 mm amplitude		20 mm amplitude	20 mm amplitude
	9 to 50 Hz	1 m/s ²	0.075 mm (from 10 Hz)	20 mm amplitude	20 mm amplitude
	50 to 57 Hz	1 m/s ²	0.075 mm		1 m/s ²
	57 to 150 Hz	1 m/s ²	9.81 m/s ²		9.81 m/s ²
	150 to 200 Hz	1 m/s ²			1 m/s ²

Function	Specification
Vibration - Storage and transport	To IEC 61800-2 which specifies Class 2M1 of IEC 60721-3-2 when equipment is packed for transport: 2 to 9 Hz 3.5 mm amplitude 9 to 200 Hz 10 m/s ² 200 to 500 Hz 15 m/s ²
Drop - Transport	To IEC 61800-2 which specifies Class 2M1 of IEC 60721-3-2 when equipment is packed for transport: mass < 100 kg = 0.25 m; mass > 100 kg = 0.10 m
Inclination	- Static conditions; list 15°, trim 5° - Dynamic conditions; rolling ± 22.5°, pitch ± 7.5° (may occur simultaneously)

3.7 Electrical Supply

Function	Specification
Network Type	TN or TT (i.e. earthed/grounded neutral) or IT [#] network (i.e. isolated neutral) # The IT network must be: <ul style="list-style-type: none"> - Separated from the public mains supply by an isolating transformer. - Protected against transients - Have earth/ground fault reference and monitor. Refer to the MV DELTA manual “Special Requirements for IT Network” for details.
INSULATION	
Voltage to Ground (Earth)	Recurring peak voltage not to exceed 1600 V (Common mode filtering may be required)
Standards	EN 50178, IEC61800-5-1, UL 840, CSA C22-2 No. 0.2,; Pollution Degree 2, TN or TT network : Overvoltage Category III IT network : Overvoltage Category II For full compliance with UL 508C, transient suppressers complying with UL 1449 must be fitted external to the drive.

3.8 Mechanical

Specification	Value
Dimensions	246mm W x 875mm H x 507mm D [575mm with APU and shrouds] (9.7” W x 34.4” H x 20” D [22.6” with APU and shrouds])
Enclosure	IP00 (IEC 60529:1989; BS EN 60529:1992) NEMA 1 Must always be installed within suitable enclosure with restricted access
Mass	71kg (156 lb.)
3D File	3D Step file can be downloaded from http://avidcontrolsinc.com/step-files/

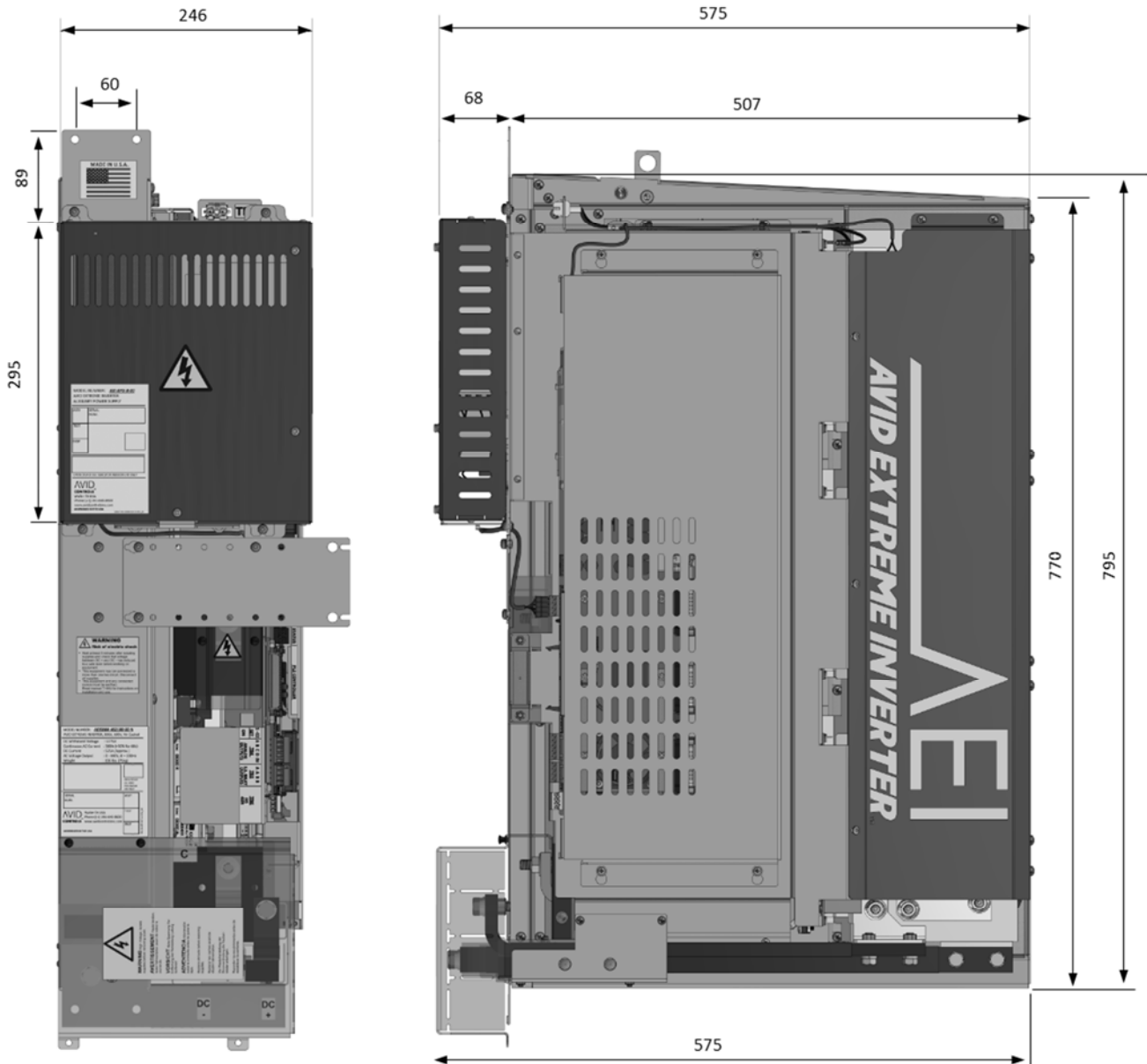

All dimensions to nearest mm
APU is shown fitted

4. High Voltage / Power Connections

Connection	Details
AC Power Terminals	1 x M10 studs per phase Maximum cable size per stud is 120mm ²
DC Power Terminals	1 x M10 studs each for DC+ and DC- Maximum cable size per stud is 120mm ²
Ground Connection	1 x M10 bolt

5. Low Voltage / Control Connections

5.1 Overview

- All control connections are made to terminals and plugs on the **Controller Interface Board** (hereinafter referred to as the **C.I.B.**) as shown in the following image (left hand side is towards the top of the unit when installed):

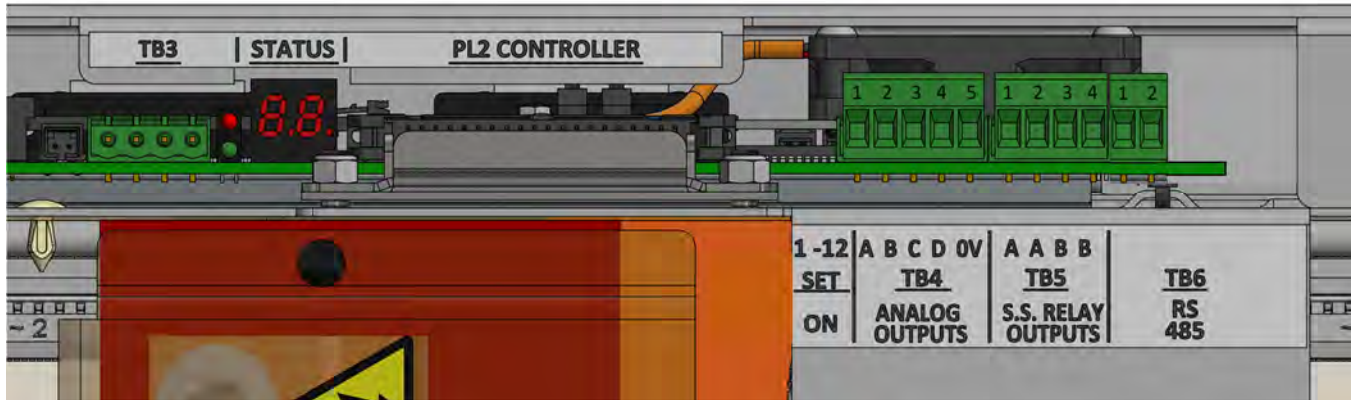

- The terminal blocks may not be physically numbered – pin one is always towards the top of the unit when installed.
- The pin numbers for TB3 are not shown since the cable and header are pre-made as part of the Auxiliary Power Unit assembly.

5.2 Plugs for TB3, TB4 & TB5

- The pluggable part of TB3 is part of the Auxiliary Power Unit assembly, hence no plug is provided or needed in the AEI module for this connector.
- The functions of TB4 (analog outputs) and TB5 (solid-state relays) are rarely used in AEI applications, and in certain Delta module replacement applications can cause a fitment issue.
- To avoid any fitment issues, and to avoid the wasteful fitting of these plugs, AEI modules ship from Avid without these plugs.
- If you wish to use these features, the following table lists some of the widely available options for these plugs:

Plug	Description	Approved Parts
TB4	Five pin 0.2” Horizontal Entry Plug	TE Connectivity: Part Number 796634-5 Molex: Part Number 395305005 Phoenix Contact: Part Number 1757048 Würth: Part Number 691351500005 Amphenol: Part Number TJ0551530000G
TB5	Four pin 0.2” Horizontal Entry Plug	TE Connectivity: Part Number 796634-4 Molex: Part Number 395305004 Würth: Part Number 691351500004 Amphenol: Part Number TJ0451530000G

- These plugs may also be obtained by contacting Avid Controls Inc.

5.3 TB3 – Auxiliary Power Supply

- Auxiliary power is generally provided to the AEI unit from an Avid Auxiliary Power Unit.
- For reference, the following gives more details of TB3:

Terminals	Function	Specifications and Notes
1, 2	AUX. PWR. SUPPLY [+]	<ul style="list-style-type: none"> • 24V DC, +/-5%, 10A maximum load • Power cycle must be monotonic • [-] terminals are connected to system 0V [GROUND] on the C.I.B.
3, 4	AUX. PWR. SUPPLY [-]	

- Customers wishing to provide their own auxiliary power must contact Avid Controls for further information. Use of a non-approved power supply will void the product warranty.

5.4 TB4 – Analog Outputs

Terminals	Function	Specifications and Notes
1, 2, 3, 4	ANALOG OUTPUT A, B, C, D	<ul style="list-style-type: none"> • Analog outputs for user diagnostic monitoring • See section 6.3 for details on selecting specific signals to be output via analog outputs. • Range is +/-10V • Maximum load current is 5mA • Output source impedance is 100Ω • Maximum error at all outputs is +/- 1% of full range with zero load
5	0V (GND)	

5.5 TB5 – Solid State Relays

Terminals	Function	Specifications and Notes
1, 2	SS RELAY A	<ul style="list-style-type: none"> Inverter module fault indication Relay energized indicates no fault condition Relay de-energized indicates a fault condition
3, 4	SS RELAY B	<ul style="list-style-type: none"> Internal cooling fan fail indication on liquid cooled units. Unused on AEI500A products
		<ul style="list-style-type: none"> Maximum operating voltage is 60Vdc / 40Vac(rms) Maximum load current is 0.4A Typical ON resistance is 0.5 Ω NOT overload (short-circuit) or overvoltage protected For reference, on-board device is <i>Panasonic AVQ202A</i> or <i>AVQ252GA</i> solid-state relay.

5.6 TB6 – RS485

- The AEI inverter has a single, non-isolated, 2-Wire RS485 (5V) port at TB6.
- The pin out of this is:

Terminal	Function
1	DATA+
2	DATA-

- Note that the DATA+/- signals are referenced to the internal 0V of the AEI, which is connected to the chassis and thus to the cabinet steelwork. The remote node of the RS485 must be similarly referenced with a maximum common mode voltage of +/-20V. For reference, the transceiver device used is a *Texas Instruments SN65HVD23*.
- See section 8, MODBUS Communications for a complete functional description of the operation of the RS485 port.
- A future revision of the AEI products will implement a fully isolated RS485 link on TB6 and provide an option for connecting an internal line termination resistor.

5.7 PL2 – Controller Connection

- Standard 40-way ribbon cable header for connection to a CDC.

6. User Selectable Options

6.1 Overview

- There are a number of options for the inverter unit that must be configured.
- These are configured using a set of 12 DIP switches on the C.I.B.
- These switches are numbered from 1 to 12, the ON position is towards the PCB itself, and the OFF position is towards the edge of the board.
- The DIP switches are very small, so a fine point instrument is needed to set them correctly.
- The default options are identified in the following descriptions.

6.2 Over-volts Trip Mode (SW1 to SW4)

- The overvoltage thresholds and delays are configured by SW1 to SW4.
- The following table defines the operation of these switches:

SWITCH SETTINGS				DC Link Voltage Trip Instant	DC Link Voltage Trip Delayed	Delay Time	Notes
SW 1	SW 2	SW 3	SW 4				
OFF	OFF	OFF	OFF	1188 Vdc	None	N/A	Legacy behavior for non-renewable energy systems
OFF	OFF	OFF	ON	1262 Vdc	1188 Vdc	0.5s	Units configured in one of these modes are used in position 1 of the system. <i>Default is 1s delay.</i>
OFF	OFF	ON	OFF			1.0s	
OFF	OFF	ON	ON			1.5s	
OFF	ON	OFF	OFF			2.0s	
OFF	ON	OFF	ON			2.5s	
OFF	ON	ON	OFF			3.0s	
OFF	ON	ON	ON			3.5s	
ON	OFF	OFF	OFF			4.0s	
ON	OFF	OFF	ON			4.5s	
ON	OFF	ON	OFF			5.0s	
ON	OFF	ON	ON			5.5s	
ON	ON	OFF	OFF			6.0s	
ON	ON	OFF	ON			6.5s	
ON	ON	ON	OFF			7.5s	
ON	ON	ON	ON	1290 Vdc	None	N/A	This mode is used in positions 2 to 6 of a parallel inverter system.

6.3 Analog Output Mode (SW5 and SW6)

- The unit provides four analog outputs for system monitoring / debugging.
- See section 5.4 for electrical specifications.
- Scaling of different signal types is as follows:

Signal Type	Scaling
Current	<ul style="list-style-type: none"> • +/- 10 V output is equivalent to +/- 2500A • Positive values are defined as positive current OUT of the AC terminals of the unit. • When the output mode is rectified phase currents, only positive values will be output. • The formula for rectified mode is: Output = MAXIMUM (Ia , Ib , Ic).
DC Link Voltage	<ul style="list-style-type: none"> • 0 to +10V is equivalent to 0 to 1500 Vdc
Temperature	<ul style="list-style-type: none"> • 0 to +10V is equivalent to 0 to 150°C • Note that due to the nature of the internal temperature sensor, any temperature below 30°C will be indicated as 30°C.

- The signals that are output are controlled by DIP switches **SW6** & **SW7**:

Switch Positions		Mode	Analog Channel Outputs			
SW5	SW6		A	B	C	D
OFF	OFF	MIXED	Full wave rectified AC currents	Maximum IGBT module temperature	Minimum IGBT module temperature	DC Link Voltage
ON	OFF	CURRENTS	A phase AC current	B phase AC current	C phase AC current	
OFF	ON	TEMPS.	A phase IGBT module temperature	B phase IGBT module temperature	C phase IGBT module temperature	
ON	ON	UNUSED	Undefined value between -10V and +10V			

- **The default mode is MIXED.**

6.4 Compatibility Rating Mode (SW7)

- Certain models of Avid Extreme Inverter may be configured to report a lower rating to the controller than that of which they are actually capable.
- This feature is provided to support compatibility with legacy systems and to increase flexibility in different applications.
- Not all Avid Extreme Inverter units support a compatibility rating.
- Compatibility Rating Mode is enabled by setting DIP switch **SW7** to the ON position (its *default is OFF*).
- There is currently no Compatibility Rating for the AEI550A

6.5 MODBUS Address Setup Switches (SW8 to SW10)

- These three switches set the MODBUS Slave Address of the AEI.
- The functions are as follows:

SWITCH SETTINGS			MODBUS SLAVE ADDRESS	Notes
SW 8	SW 9	SW 10		
OFF	OFF	OFF	1	As can be seen, the MODBUS slave address is $1 + SW[8..10]$
OFF	OFF	ON	2	
OFF	ON	OFF	3	
OFF	ON	ON	4	
ON	OFF	OFF	5	
ON	OFF	ON	6	
ON	ON	OFF	7	
ON	ON	ON	8	

- A future revision of the AEI product will implement a dedicated switch array for MODBUS address and optional line termination.
- See section 8 for details of the MODBU communication function.

6.6 Unused Switches (SW11 to SW12)













- These switches currently have no assigned functions.
- They should be left in the OFF position.

7. LED's and Fault Indication

- The unit has two discrete LED's (red and green) and a two-digit LED display.
- The discrete LED's indicate the operational state of the unit and the numeric display may either indicate various feedback signals or all active faults.

7.1 Discrete LED's

 - OFF
  - ON
  - FLASHING

RED LED	GREEN LED	Meaning
		Auxiliary supply is not present
		Internal error present on C.I.B. or auxiliary supply is out of tolerance
		Unit healthy (not tripped) and disabled (IGBT's not switching)
		Unit healthy (not tripped) and enabled (IGBT's switching)
		Unit faulted. Fault codes will be displayed on 2-digit display, appropriate fault codes sent to controller (as supported – see section0)
		Controller is attempting a reset cycle

7.2 Program Version Display

- When the auxiliary power is applied, the 2-digit LED displays the C.I.B. program version for three seconds.
- This version will be required by Avid when providing technical assistance.

7.3 LED Feedback Indication

- After power up, when the unit is not faulted, the 2-digit LED display cycles through indications of several operational feedbacks.
- Each feedback is displayed for 1s, before the display cycles to the next feedback. A "--" pattern is used to indicate the start of the cycle.
- The cycle is:

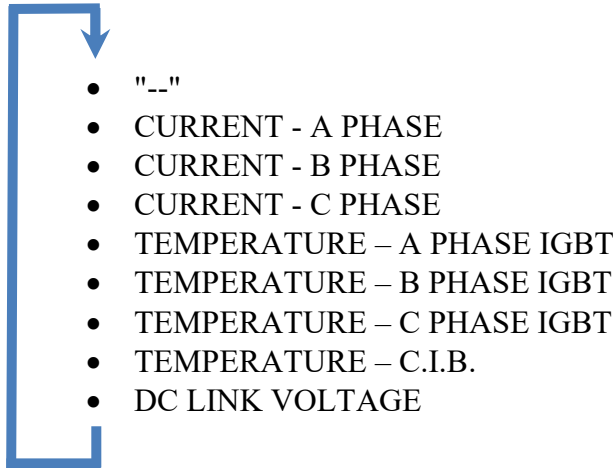

- In a similar manner to the analog outputs, most values are displayed as the percentage of a defined value. The exception is the C.I.B. temperature which is displayed in °C.

Signal Type	Explanation & Scaling
Current	<ul style="list-style-type: none"> • 100% output is equivalent to 2500A • The formula for the indication is: <ul style="list-style-type: none"> ○ % CURRENT = 100% X AVERAGE_{1s} (Phase Current) / 2500A • Or, in words, the formula is <i>the absolute current averaged over 1s, expressed as a percentage of 2500A</i> • This will produce fluctuating display values at lower power frequencies as the 1s average period beats with the current waveform • For reference, the relationship between AVERAGE OF MEAN and RMS values for a sinusoid is AVERAGE = 0.90 X RMS
DC Link Voltage	<ul style="list-style-type: none"> • Average over 1s expressed as percentage of 1500 Vdc
IGBT Temperature	<ul style="list-style-type: none"> • Expressed as percentage of 150°C (0°C = 0%, 150°C = 100%) • Note that due to the nature of the internal temperature sensor, any temperature below 30°C will be indicated as 20%.
C.I.B. Temperature	<ul style="list-style-type: none"> • This is displayed in °C • Note due to absence of negative sign any value below 0°C will be displayed as '00'

7.4 Fault Codes

- When the unit has a fault, the 2-digit LED display cycles through a list of all active faults.
- Each fault that the unit recognizes is encoded into a compatible fault code for indication by the controller.
- The Avid unit can identify many more and different faults than the controller can recognize, so some rationalization has been necessary.
- The following table describes each fault code on the unit, together with the fault code that is transmitted to the controller for each of the faults recognized by the C.I.B.:

Fault Code on LED Display	Meaning	Trip Code Transmitted to Controller*1
1	A Phase IGBT Self-Protect Fault	31
2	B Phase IGBT Self-Protect Fault	33
3	C Phase IGBT Self-Protect Fault	35
4	A Phase Heatsink Over Temperature Fault	32
5	B Phase Heatsink Over Temperature Fault	34
6	C Phase Heatsink Over Temperature Fault	36
7	A Phase Silicon Over Temperature Fault	32
8	B Phase Silicon Over Temperature Fault	34
9	C Phase Silicon Over Temperature Fault	36
10	Over Voltage (DC Link)	38
11	External Trip Fault	37
12	Internal Fan 1 Failure (on units where this fan is fitted)	243
13	Internal Fan 2 Failure (on units where this fan is fitted)	243
14	Internal Fan 3 Failure (on units where this fan is fitted)	243
15	External Fan Failure (on units where this fan is fitted)	243
16	Incoming Power Supply Fault	240
17	Internal Power Supply Fault (+15V)*2	241
18	Internal Power Supply Fault (-15V)*2	242
19	Internal Power Supply Fault (IGBT)*2	240
20	Internal Power Supply Fault (+3V5)*2	240
21	Internal PWM Deadtime Fault (A Phase)*2	247
22	Internal PWM Deadtime Fault (B Phase)*2	248

Fault Code on LED Display	Meaning	Trip Code Transmitted to Controller* ¹
23	Internal PWM Deadtime Fault (C Phase)* ²	249
24	Internal PWM Frequency Fault (A Phase)* ²	244
25	Internal PWM Frequency Fault (B Phase)* ²	245
26	Internal PWM Frequency Fault (C Phase)* ²	246
27	A Phase Positive Instantaneous Overcurrent	31
28	A Phase Negative Instantaneous Overcurrent	31
29	B Phase Positive Instantaneous Overcurrent	33
30	B Phase Negative Instantaneous Overcurrent	33
31	C Phase Positive Instantaneous Overcurrent	35
32	C Phase Negative Instantaneous Overcurrent	35
33	DC Link Feedback Fault* ²	212
34	Internal Fault* ²	212

***1:** The fault code for a unit connected to position 1 of the controller system is given. For units in other positions the equivalent fault code will be displayed by the controller.

***2:** These faults indicate a fault within the inverter unit. They do not occur in normal operation and user fault-finding is generally not possible. In the unlikely event that these faults are experienced, contact Avid Controls for support.

8. MODBUS¹ Communications

8.1 Introduction

- The AEI implements a small subset of the MODBUS RTU SLAVE PROTOCOL via the 2-wire RS485 port on TB6.
- The port has the following physical and data specifications:
 - Electrical Levels: TIA/EIA RS485, 5V
 - Isolation: None. Signals are referenced to system 0V (chassis).
Maximum common mode voltage is +/-20V.
A future revision will implement a fully isolated RS485 link at TB6
 - Baud Rate: 115200 bits per second
 - Parity: None
 - Data Bits: 8
 - Stop Bits: 1
 - Termination: None. If needed an external termination resistor must be added at TB6.
A future revision will implement an optional internal 120Ω termination resistor.

8.2 MODBUS_TIMER

- The AEI maintains a 1ms timer, **MODBUS_TIMER**, that counts continuously and overflows from 65535 to 0 every 65.536 seconds.
- The value of **MODBUS_TIMER** is one of the diagnostic fields that is provided via the MODBUS link.
- The following MODBUS function is used to synchronize **MODBUS_TIMER** between all AEI's connected to the MODBUS network:
 - MODBUS Address: 00 (Global Address)
 - MODBUS Function: 06 – Write Single Register
 - Register Address: 0
 - Write Data: Data is loaded immediately (< 1ms) into **MODBUS_TIMER** by all AEI's that validate the received message

8.3 Diagnostic Data

- The AEI will transmit 32 words of diagnostic data in response to a MODBUS query.
- The following MODBUS function is used to read diagnostic data from the AEI:
 - MODBUS Slave Address: 01 to 08, switch selectable
 - MODBUS Function: 03 – Read Holding Registers
 - Base Register Address: 0
 - Read Length: 32

¹ MODBUS is a registered trademark of Schneider Automation Inc.

- The following table defines the diagnostic data that is transmitted:

REG.	NAME	TYPE	NOTES
0	SER_NUM	UNSIGNED	This is the AEI serial number. Does not change.
1	TIMER	UNSIGNED	Free running <i>1ms</i> timer that can be written using MODBUS Global Address – see section 8.2. Sampled when read.
2	FAULT_1_16	BIT FIELD	Bit 0 is FAULT_1 Bit 15 is FAULT_16
3	FAULT_17_32	BIT FIELD	Bit 0 is FAULT_17 Bit 15 is FAULT_32
4	FAULT_33_48	BIT FIELD	Bit 0 is FAULT_33 Bit 15 is FAULT_48
Each bit of these <i>bit fields</i> indicates if the fault designated by the equivalent code is active. See section 7.4 for list of fault codes. Sampled when read.			
5	FAN_1_SPEED	UNSIGNED	The speed, in <i>RPM</i> , of the internal cooling fans. Sampled when read.
6	FAN_2_SPEED	UNSIGNED	Note that the AEI detects a fault if these speeds fall below safe values (the exact value varies based upon a number of factors).
7	FAN_3_SPEED	UNSIGNED	These are provided to allow the user to compare speeds <i>between</i> AEI's and with <i>historical</i> values, giving the possibility of identifying a unit with a fan problem prior to failure.
8	MAX_POS_CURRENT_A	SIGNED	The maximum positive current, in <i>AMPS</i> , of each output phase of the AEI, since the diagnostic data was last transmitted. This will be a positive value.
9	MAX_POS_CURRENT_B	SIGNED	
10	MAX_POS_CURRENT_C	SIGNED	
11	MAX_NEG_CURRENT_A	SIGNED	The maximum negative current, in <i>AMPS</i> , of each output phase of the AEI, since the diagnostic data was last transmitted. This will be a negative value.
12	MAX_NEG_CURRENT_B	SIGNED	
13	MAX_NEG_CURRENT_C	SIGNED	
14	AVG_CURRENT_A	SIGNED	The average absolute current, in <i>AMPS</i> , of each output phase of the AEI, since the diagnostic data was last transmitted.
15	AVG_CURRENT_B	SIGNED	Note that the current is first rectified before the average is calculated, so that positive or negative output currents are not differentiated.
16	AVG_CURRENT_C	SIGNED	Note that (due to storage limits) the evaluation of average is suspended after 32767 PWM periods of evaluation (13s at 2.5kHz PWM). So to utilize this data, it must be accessed at least this often.
17	IGBT_TEMP_A	SIGNED	The temperature, in <i>0.1°C</i> units, of the IGBT temperature feedback devices. Sampled when read.
18	IGBT_TEMP_B	SIGNED	
19	IGBT_TEMP_C	SIGNED	
20	MAX_IGBT_TEMP_A	SIGNED	The maximum temperature, in <i>0.1°C</i> units, of the IGBT temperature feedback devices since the diagnostic data was last read.

REG.	NAME	TYPE	NOTES
21	MAX_IGBT_TEMP_B	SIGNED	
22	MAX_IGBT_TEMP_C	SIGNED	
23	CIB TEMPERATURE	SIGNED	The CIB temperature in <u>1°C</u> units. Sampled when read.
24	DC_VOLTS	SIGNED	The current value, in <u>0.1V</u> units, of the measured DC link voltage. Sampled when read.
25	MAX_DC_VOLTS	SIGNED	The maximum value, in <u>0.1V</u> units, of the measured DC link voltage since the diagnostic data was last read.
26	STATUS	BIT FIELD	BIT 0: TRIPPED
			BIT 1: ENABLED
			BIT 2: FAN FAIL
			OTHER BITS: ZERO
27	SENSOR 1	UNSIGNED	The AEI has three internal sensors, CURRENTLY UNUSED, able to measure 0-10V signals from a variety of optional sensors. These registers give the sensor values, in <u>1mV</u> units. Sampled when read.
28	SENSOR 2		
29	SENSOR 3		
30	UNUSED	UNSIGNED	These words are stuck at ZERO.
31			

9. System Design Requirements to Satisfy UL508C

- UL 508C has several requirements that must be satisfied:
 - Motor over-temperature monitoring is required. Details of the required connections to the User I/O panel are given in T1689;
 - Semiconductor fuses should be located within the same enclosure as the AEI module;
 - The integral short circuit protection provided by the AEI module does not provide branch circuit protection. Branch circuit protection must be provided in accordance with the National Electric Code and any additional local codes.

9.1 EMC Bonding for Electromagnetic Compatibility

- The AEI power modules must be bonded together and to the drive control module.
-
- A bonding plate is supplied with the AEI module to aid with this EMC bonding.
- - These plates form a single metal highway providing a low resistive, low inductive path between the modules and the controller.
 - This arrangement forms a ground plane, against which the control ribbon cables are run, improving the noise immunity of the system.
 - The plate is secured using the screws supplied, pre-fitted to the front of the DELTA module.

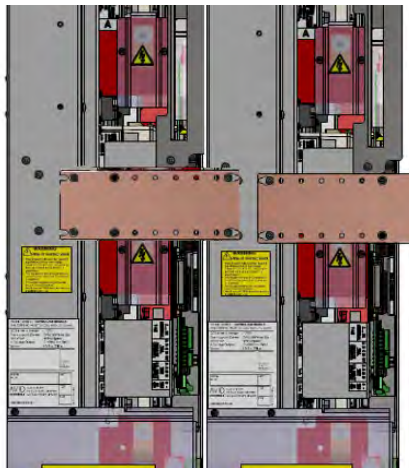

Bonding plates linking adjacent AEI Modules

- The installer of the modules into the enclosure must complete the bonding path (and cable routing) of the AEI modules to the MV3000 controller.
- The dimensions of this plate depend on the location of the controller and so cannot be supplied with the module.
- The ribbon cable between the DELTAs and the control module must be screened and bonded at both ends.

9.2 Enclosure

- This module is as an ‘open type’ product (IP00) for installation into an enclosure (cabinet / cubicle).

9.2.1 Enclosure Requirements

- The essential requirements for the enclosure are:
 - Protection of personnel against direct contact of hazardous parts:
 - Electrical – all hazardous live parts, e.g. the AEI module power circuit
 - Thermal - hot parts (on the AEI module, the heatsink and busbars; for the system these plus high temperature cables, reactors, etc.)
 - Moving parts – on the AEI none; on the system: the impellers of the cooling fans
 - Energy hazards – Electrical (including the stored energy in the dc capacitor bank, which takes up to five minutes to discharge), the rotational mechanical energy in the fan (this stops within a few seconds) and the energy that could be supplied into the enclosure during catastrophic failure of any part of the system ‘arc-containment’.
 - Protection of the enclosed equipment against the environmental conditions
 - Mechanical impact against the enclosure
 - Environmental control against the ingress of water, dust and solid objects
 - Condensation control to meet the requirements of Pollution Degree 2 (see Section **Error! Reference source not found.**)
 - Reduction of radiated emissions from the drive and protection of the drive from radiating sources.

9.2.2 AEI Module Construction

- The front of the unit is supplied with terminal shrouds to aid in the requirement to provide accidental protection to personnel against direct electrical contact during ‘proving dead’ procedures.
- All the insulation materials used in the AEI module have a low flammability rating when tested against UL 94 (limited burn rate; will self-extinguish and do not drop burning particles when the source of ignition is removed).
- The DC link capacitor bank has discharge resistors fitted to discharge the capacitors to below 50V in less than 5 minutes after the isolation of the supply.

9.2.3 Enclosure Construction Requirements

Steel Enclosure

- To provide a conductive and magnetic screen in addition to safety segregation.

Earthing / Grounding

- To be locally earthed/grounded for both safety and for EMC.
- Note converters contain high leakage current equipment.
- Panels to be bonded together for earth/ground continuity and continuation of conductive screen/shield

Openings

- Designed to protect personnel (and equipment) against hazards.
- Avoid all unnecessary apertures.
- All doors and covers to hazardous parts to be closed when the equipment is energized.

10. Spares and Service

The AEI contains no user serviceable parts. For repairs and replacement product contact:

Avid Controls Inc.
 41261 Park 290 Drive,
 Waller, TX 77484, USA

info@avidcontrolsinc.com

(+1) (281) 640-8600

11. Document Revision History

Rev.	Date	Author	Changes
00	Mar 22 2019	Mark Woods	Document created
01	Aug 15 2024	Gary Pace	Note about not-fitted TB's on CIB added.