

REV 02
Jun 4, 2025

Avid Controls Inc.
41261 Park 290 Drive, Waller, TX 77484, USA
info@avidcontrolsinc.com
(+1) (281) 640-8600

AVID Controls Inc. pursues a policy of continuous product improvement and innovation. This may not be the latest revision of this publication and may not reflect all current product changes. Contact AVID Controls Inc. for the latest revision of this data sheet and information on other product enhancements.

Intentionally Blank

Contents

1.	Introduction	5
1.1	Terms and Definitions	5
1.2	Related User Documents	5
2.	WARNINGS	6
3.	Specification	7
3.1	Model Numbers	7
3.2	Electrical – Power Section	8
3.3	Electrical – Control & Interface Section	9
3.4	Cooling	10
3.4.1	Heat Loads to Coolant	11
3.5	Environmental	12
3.6	Mechanical	13
4.	High Voltage / Power Connections	14
5.	Low Voltage / Control Connections	15
5.1	Overview	15
5.2	Plugs for TB3, TB4 & TB5	16
5.3	Shipping/Handling Protector for 40-Way Ribbon, PL2	17
5.4	TB3 – Auxiliary Power Supply	18
5.5	TB4 – Analog Outputs	18
5.6	TB5 – Solid State Relays	19
5.7	TB6 – RS485	19
5.8	PL2 – Controller Connection	20
6.	User Selectable Options	20
6.1	Overview	20
6.2	Over-volts Trip Mode (SW1 to SW4)	21
6.3	Analog Output Mode (SW5 and SW6)	21
6.4	Compatibility Rating Mode (SW7)	23
6.5	MODBUS Address Setup Switches	24
6.6	MODBUS Sample Mode	24
6.7	Unused Switches	24
7.	LEDs and Fault Indication	25
7.1	Discrete RED & GREEN LEDs	25
7.2	Discrete YELLOW LED	25
7.3	Program Version Display	25
7.4	LED Feedback Indication	26
7.5	Fault Codes	27
7.6	Internal Cooling Fan Fault	29
8.	MODBUS Communications	30
8.1	Introduction	30
8.2	MODBUS_TIMER	30
8.3	Diagnostic Data	30
8.4	MODBUS Sample Mode	33
9.	Contact Details: Sales, Service and Support	34
10.	Document Revision History	34

11.	Appendix A – Application Information	35
11.1	Introduction to Application Concepts	35
11.2	Liquid Cooled Avid Extreme Inverter Modules.....	36
11.3	Variable Frequency Drive Topologies	38
11.3.1	Diode Front End (DFE).....	38
11.3.2	Active Front End (AFE).....	39
11.4	Integrating the AEI into the Power Drive System.....	39
11.5	Installation.....	41
11.5.1	Enclosure/Cabinet Information	41
11.5.2	Fitting the Avid Extreme Inverter	42
11.6	Protection Requirements	44
11.6.1	Access.....	44
11.6.2	Low Voltage Circuits	44
11.6.3	Fuses.....	45
11.6.4	Motor Overload & Thermal Protection.....	46
11.6.5	Grounding Requirements	47
11.6.6	Shrouding	48
11.6.7	Other Safety/Protection Requirements.....	48
11.6.8	Specific Application Requirements to Comply with UL 61800-5-1.....	49
11.6.9	Bonding	49
11.6.10	Shielded Control Ribbon Cables	50
11.6.11	Cooling Fans.....	51

AVID CONTROLS and the  logo are registered trademarks of Avid Controls Inc.
MODBUS is a registered trademark of Schneider Automation Inc.

1. Introduction

- The AEI900L/AEI1000L/AEI1250L and AEI1400L are high reliability liquid cooled inverter modules with nominal ratings of 900A, 1000A, 1250A and 1400A. They are designed for use with MV3000 AC drives, controlled by the Common Drive Controller (CDC) on 600/690V systems.
- The AEI900L can also be operated at a nominal rating of 800A for compatibility purposes.
- Its significant technical attributes are:
 - Sintered solder-free IGBT modules for extended life operation
 - Ruggedized IGBT die for improved environmental robustness
 - Reduced internal voltage overshoot
 - More robust, fully digital gate driver
 - IGBT modules are fully sealed for protection from condensation
 - Continuous, accurate monitoring of IGBT silicon temperature under all operating conditions

1.1 Terms and Definitions

AEI	Avid Extreme Inverter
AEI-APU-X	Avid Extreme Auxiliary Power Unit
AFE	Active Front End
CDC	Common Drive Controller
CDM	Complete Drive Module
CIB	Controller Interface Board
CPT	Control Power Transformer
DFE	Diode Front End
IGBT	Insulated Gate Bipolar Transistor
PCB	Printed Circuit Board
PDS	Power Drive System
PWM	Pulse Width Modulation
SFE	Sinusoidal Front End
System	General term for the PDS
THD	Total Harmonic Distortion

1.2 Related User Documents

- The documents below are available on request from Avid Controls:

Document Number	Description
DTS-MID0124	Auxiliary Power Unit Types D, E & F Customer Data Sheet
DTS-02175-ASY-A	Auxiliary Power Unit Type G Customer Data Sheet
DTS-01944-ASY-A	AEI Upgrade, Control Power Transformer Data Sheet

- These documents are provided with the purchase of the specific products detailed.
- These should be kept for the life of the product.

2. WARNINGS

The operation of this equipment requires detailed installation and operation instructions provided in this manual; this information should be retained with this product.

- This equipment may be connected to more than one live circuit.
- All power supplies must be switched off and isolated before working on the equipment, failure to do so could result in death or serious injury.
- Wait at least 8 minutes after isolating supplies and check that the voltage between DC+ and DC- has reduced to a safe level before working on the equipment.
- Risk of burn - surfaces on the coolant pipes, cables and busbars can reach high temperatures and remain hot for some time after power is removed.
- Ensure that all coolant has cooled to a safe temperature and the equipment is suitably drained and isolated before the external pipework is disconnected from the equipment.
- Unit is heavy: 105kg (231 lb.) for the AEI900L/AEI100L and 125kg (276 lb.) for the AEI1250L/AEI1400L.
- The AEI modules are of IP00 construction and must be built into an enclosure or cabinet.
- If the Power Drive System that utilizes AEI modules is configured to auto-restart, the motor may start rotating without an operator input. Precautions Must be taken to prevent injury to personnel.
- Units are designed and manufactured to comply with EN 61800-5-1 and certified to UL 61800-5-1. To maintain this certification when used with a controller other than the MV3000 Common Drive Controller (CDC), motor thermal protection as detailed in section 11.6.4 **MUST** be implemented.

3. Specification

3.1 Model Numbers

- All Avid Extreme Inverter products use a consistent Model Number scheme:

AEI xxx c – 000000 – mm – g

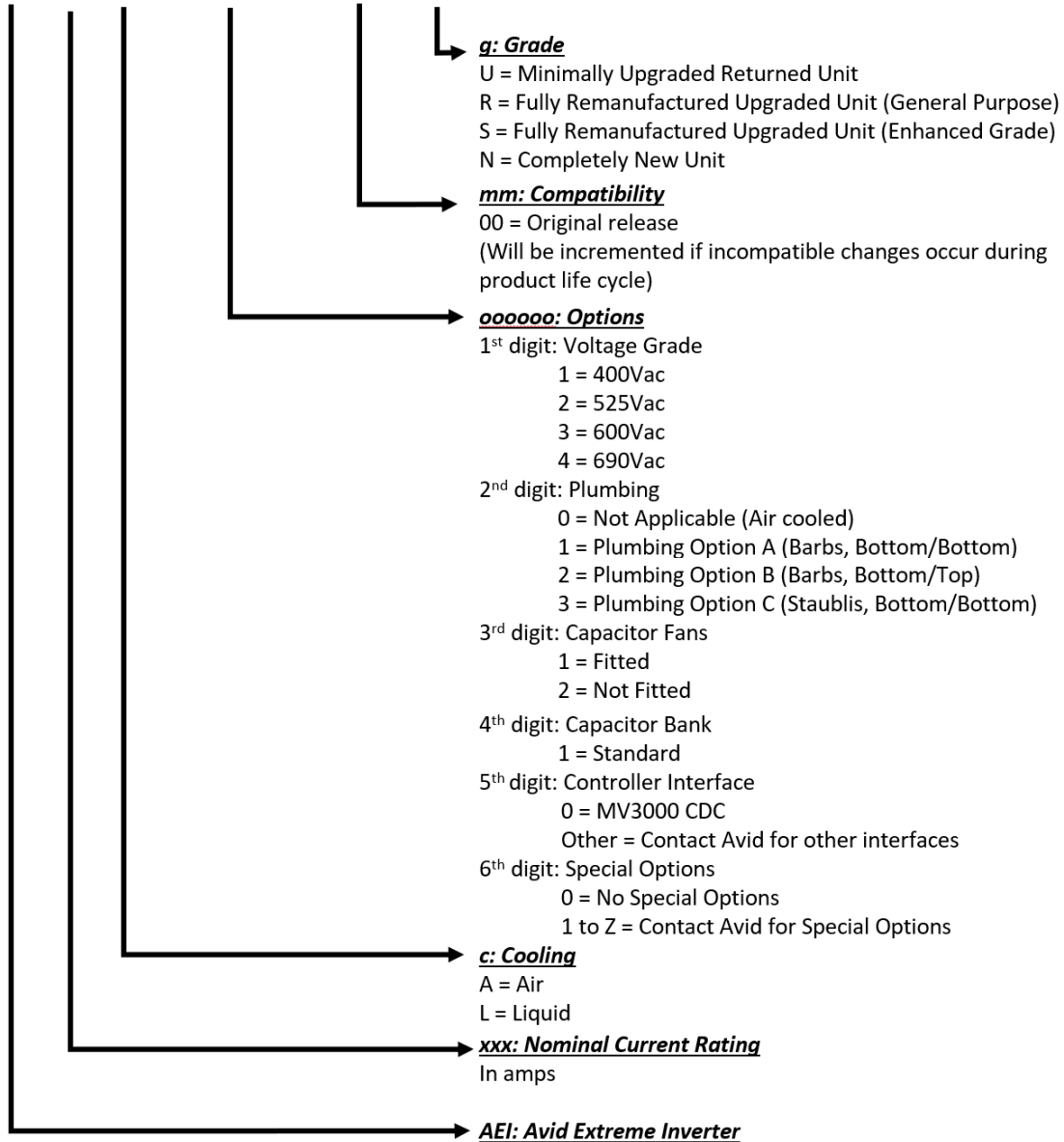

- Unless otherwise stated, this data sheet is applicable to all CDC interfaced Avid Extreme Inverter models beginning AEI900L, AEI1000L, AEI1250L and AEI1400L.
- Note that not all options that can be defined by this scheme are actual products – contact Avid Controls for specific product availability.

3.2 Electrical – Power Section

Specification	AEI900L	AEI1000L	AEI1250L	AEI1400L	Notes & Applicable Conditions
Continuous Current, 690V Renewable Energy Applications*	900A	1000A	1250A	Contact Avid	60s Overload = 110% once per 10 minutes DC Link Voltage = 1100V Coolant Temp. = 60° (AEI900L/AEI1000L) Coolant Temp. = 50° (AEI1250L) PWM Frequency = 1.8kHz (Generator) = 2.5kHz (Network) Generator Power Factor = -0.89 Network Power Factor = 1.00 Generator & Mains Freq. > 20Hz
Continuous Current, 600V Pump Applications*	900A	1000A	1250A	1400A	60s Overload = 110% once per 10 minutes DC Link Voltage = 850V Coolant Temp. = 60° (AEI900L/AEI1000L) Coolant Temp. = 50° (AEI1250L/AEI1400L) PWM Frequency = 2.5kHz Motor Power Factor = 0.85 Motor Frequency > 20Hz
Continuous Current, 690V Pump Applications*	900A	1000A	1250A	Contact Avid	60s Overload = 110% once per 10 minutes DC Link Voltage = 975V Coolant Temp. = 60° (AEI900L/AEI1000L) Coolant Temp. = 50° (AEI1250L/AEI1400L) PWM Frequency = 2.5kHz Motor Power Factor = 0.85 Motor Frequency > 20Hz
Continuous Current, 600V Hoist Applications*	660A	733A	916A	1026A	60s Overload = 150% once per 10 minutes DC Link Voltage = 820V Coolant Temp. = 60° (AEI900L/AEI1000L) Coolant Temp. = 50° (AEI1250L/AEI1400L) PWM Frequency = 2.5kHz Motor Power Factor = 0.85 Motor Frequency > 1Hz
Continuous DC Link Operating Voltage	1188 V				
Short Term (7.5s) DC Link Operating Voltage	1262 V				
Non-Operating DC Link Withstand Voltage	1350 V				
DC Link Capacitance	11600 μ F	16800 μ F	16433 μ F	23800 μ F	+20/-10 %
Maximum PWM Frequency	2.5 kHz				In some circumstances, higher frequencies may be used with de-rating – contact Avid Controls if this is required.

* For other applications contact AVID Controls Inc.

3.3 Electrical – Control & Interface Section

Specification	<i>AEI900L / AEI1000L</i>	<i>AEI1250L / AEI1400L</i>	Notes
Control Power Source	Avid Auxiliary Power Unit (APU) Model Numbers: AEI-APU-B AEI-APU-C AEI-APU-D AEI-APU-E AEI-APU-F AEI-APU-G AEI-APU-H	Avid Auxiliary Power Unit (APU) Model Numbers: AEI-APU-C AEI-APU-D AEI-APU-E <u><i>AEI-APU-G or AEI-APU-H models DO NOT work with these AEI models.</i></u>	Customers wishing to provide their own auxiliary power <u>MUST</u> contact Avid Controls for further information. Models AEI-APU-B & -C are legacy items no longer produced by Avid Controls. See Avid Data Sheets DTS-MID0124 for complete data on the -D,-E & -F models, and DTS-02175-ASY-A for the -G model.
Analog Outputs	4 Channels +/-10V		Optional indication for phase currents, temperatures etc. DIP switch function selection See section 6.3 for more details
Fault Indication	<ul style="list-style-type: none"> • Fault Codes indicated by controller for all compatible faults • Two-digit LED display for additional diagnostic codes • Two 24V Solid-State relay outputs for indication of fault status 		See section 7.5 for definition of fault codes.
Operational Indication	Two-digit LED display for display of DC link voltage, currents and temperatures		See section 7.4 for details.
Remote Monitoring	Two wire RS485 fully isolated MODBUS RTU Protocol		See section 8 for details.
DC Link Voltage Feedback Accuracy	+/- 4V @ 1000V DC		Measured internally within inverter unit

3.4 Cooling

Specification	<i>Value</i>
Coolant Type* ¹	Water / Ethylene Glycol Maximum 50% Ethylene Glycol With suitable corrosion inhibitors
Minimum Coolant Flow	25 liters/min (6.6 US-GPM)
Maximum Coolant Inlet Pressure	300kPa (45psi)
Maximum Coolant Inlet Temperature	60°C (Derate 2%/°C above 50°C for AEI1250L & AEI1400L)
Minimum Coolant Inlet Temperature	0°C
Coolant Strainer	Coolant must be strained to remove particles Maximum recommended strainer mesh is 0.7mm (0.028") Inspect and clean strainer every six months
Coolant Lifetime	Check coolant constituent concentration every six months Remove coolant, flush system with de-ionized water and refill with new coolant every 24 months.
Coolant Connection Options* ^{2*3}	<ul style="list-style-type: none"> • 2x hose-barb at bottom of unit (Option A) • 1x hose-barb top, 1x hose-barb bottom (Option B) • 2x Quick-Disconnect at bottom of unit (Option C)*⁴

*1: The materials used in all cooling system components must be compatible with ethylene glycol. Incompatible materials may be corroded or degraded over time causing leakage. Therefore, it is important to check the compatibility of the coolant with all components.

*2: Where the AEI module is fitted with hose-barb connectors, the recommended flexible hoses are silicone rubber or ethylene propylene diene monomer (EPDM) reinforced with textile braid. Inside diameter = 19mm (3/4").

*3: Flexible hose should be secured using stainless steel hose clamps that provide 360° even pressure around the hose and have rounded edges to prevent pipe damage. “Worm” clamps are not recommended. Recommended types include Norma GBS M 29-31/18 W4 SK.

*4: AEIs with plumbing option C are fitted with Self-sealing Staubli RME 16 connectors.

3.4.1 Heat Loads to Coolant

<p>Typical heat loads to coolant (allow 33% more than quoted values when designing cooling system)</p>	DC Link V	PWM Freq. kHz	Power Factor	Current A	Typical Heat Load kW
	1100	2.5	1.0	800	8.7
				900	10.0
				1000	11.5
				1250	14.8
	1100	1.8	-0.89	800	7.0
				900	8.0
				1000	9.1
				1250	11.8
	976	1.25	0.90	900	6.3
				1000	7.2
				1250	9.4
	850	1.25	0.90	900	5.9
				1000	6.7
				1400	10.3
850		2.5	0.90	900	8.1
				1000	9.1
				1400	14.0

3.5 Environmental

Specification	Value
Ambient Temperature (Internal cabinet temperature) - Operating	0 to 50°C
Temperature – Storage or Transport	-13°F to 131°F (-25 to +55°C)
Altitude – Operating	Up to 3280ft. (1000m) ASL. Between 3280ft. (1000m) and 6551ft. (2000m) apply derating of 7.5% per 3280ft. (1000m).
Altitude – Storage	Up to 9842ft. (3000m) ASL
Altitude - Transport	Will withstand air transport
Vibration – Transport	IEC 60721-3-2:1997 Class 2M1, in transport packaging.
Humidity – Operating, Storage or Transport	5% to 95% RH, Non-condensing.
Cabinet air – Operating	Pollution Degree 2 as per IEC60664-1, UL 840 & CSA C22.2 No. 0.2-93 i.e. clean, free from dust, condensation and conductive or corrosive gases. Maximum chemicals 15ppm H ₂ S, 25ppm NO ₂ , 25ppm SO ₂

3.6 Mechanical

Specification	Value
Dimensions	248mm W x 1232mm H x 546mm D (9.75" W x 48.5" H x 21.5" D)
Enclosure	IP00 (IEC 60529:1989; BS EN 60529:1992) NEMA 1 Must always be installed within suitable enclosure with restricted access
Mass	105kg (231 lb.) for AEI900L/AEI1000L 125 kg (276 lb.) for AEI1250L/AEI1400L

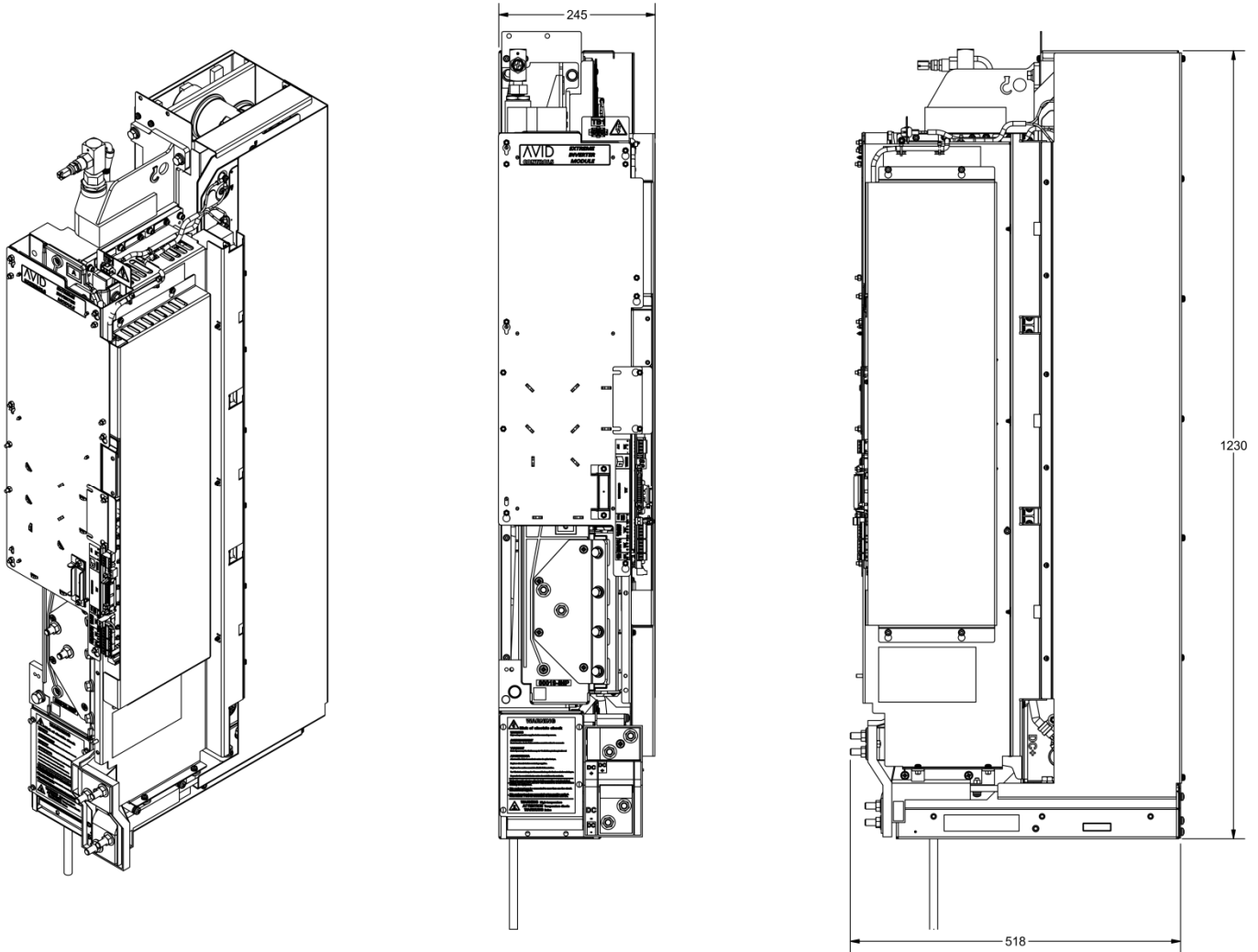

4. High Voltage / Power Connections

Connection	<i>Value for AEI900L</i>	<i>Value for AEI1000L/AEI1250L/AEI1400L</i>
AC Power Terminals	2 x M10 studs per phase	3 x M10 studs per phase
DC Power Terminals	2 x M10 studs each for DC+ and DC-	3 x M10 studs each for DC+ and DC-
Ground Connection	1 x M10 bolt	

- Recommended fastening torque for power terminals is 35Nm (26 ft-lbs.).
- It is not recommended to terminate more than one power cable per fastener on the AEI module.
- Maximum cable size per stud/bolt is 250MCM or 120mm².
- All power cables must have insulation rated to a minimum temperature of 125°C. Recommended insulation materials include high temperature silicone rubber and extruded radiation-crosslinked polyolefin.
- AC and GROUND cables must have insulation rated to a minimum of 690V AC.
- DC cables must have insulation rated to a minimum of 1200V DC.
- Suitable cable types include:
 - Nexans - SIWO-KUL B10 1x120 1.1Kv YE (120mm² 250MCM) P/N10148828.
 - Huber and Shuner - Radox 125 600/1000V AC (120mm² 250MCM).

5. Low Voltage / Control Connections

5.1 Overview

- All control connections are made to terminals and plugs on the *Controller Interface Board* (hereinafter referred to as the *C.I.B.*) as shown in the following image (left hand side is towards the top of the unit when installed):

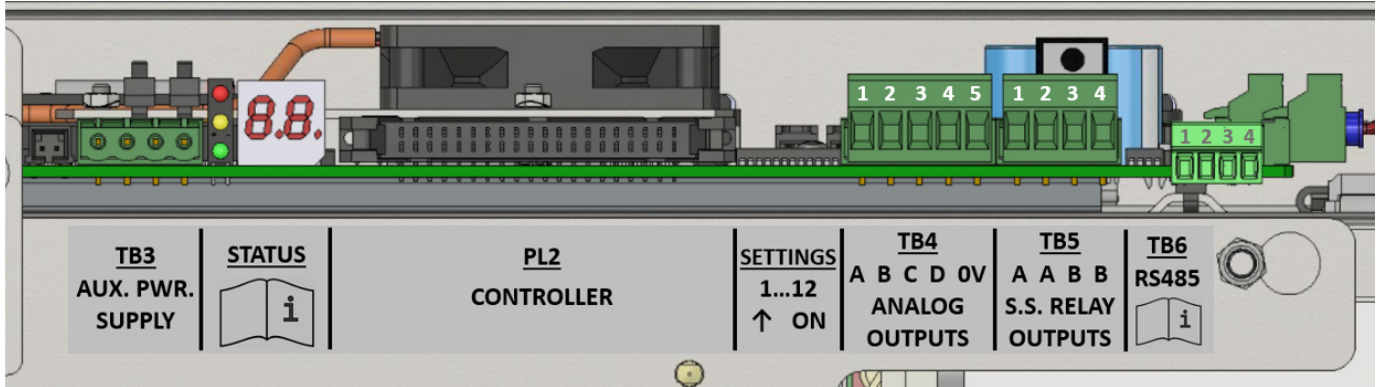

- The terminal blocks may not be physically numbered – pin one is always towards the top of the unit when installed.
- The pin numbers for TB3 are not shown since the cable and header are pre-made as part of the Auxiliary Power Unit assembly.
- The recommended wire sizes for TB4, TB5 and TB6 are from 0.5mm² (20 AWG) to 1.5mm² (16 AWG).
- The recommended fastening torque is 0.6Nm (5.3 in-lbs.)

5.2 Plugs for TB3, TB4 & TB5

- The pluggable part of TB3 is part of the Auxiliary Power Unit assembly, hence no plug is provided or needed in the AEI module for this connector.
- The functions of TB4 (analog outputs) and TB5 (solid-state relays) are rarely used in AEI applications, and in certain Delta module replacement applications can cause a fitment issue. To avoid any fitment issues, and to avoid the wasteful fitting of these plugs, AEI modules ship from Avid without these plugs.
- The following table lists some of the widely available options for these plugs:

Plug	Description	Approved Parts
TB4	Five pin 0.2” Horizontal Entry Plug	TE Connectivity: Part Number 796634-5 Molex: Part Number 395305005 Phoenix Contact: Part Number 1757048 Würth: Part Number 691351500005 Amphenol: Part Number TJ0551530000G
TB5	Four pin 0.2” Horizontal Entry Plug	TE Connectivity: Part Number 796634-4 Molex: Part Number 395305004 Würth: Part Number 691351500004 Amphenol: Part Number TJ0451530000G

- These plugs may also be obtained by contacting Avid Controls Inc.

5.3 Shipping/Handling Protector for 40-Way Ribbon, PL2

- The 40-way ribbon connector, PL2, is shipped from Avid with a protector to prevent damage during handling of the AEI module.
- This should be removed immediately prior to carefully inserting the ribbon cable from the CDC module:

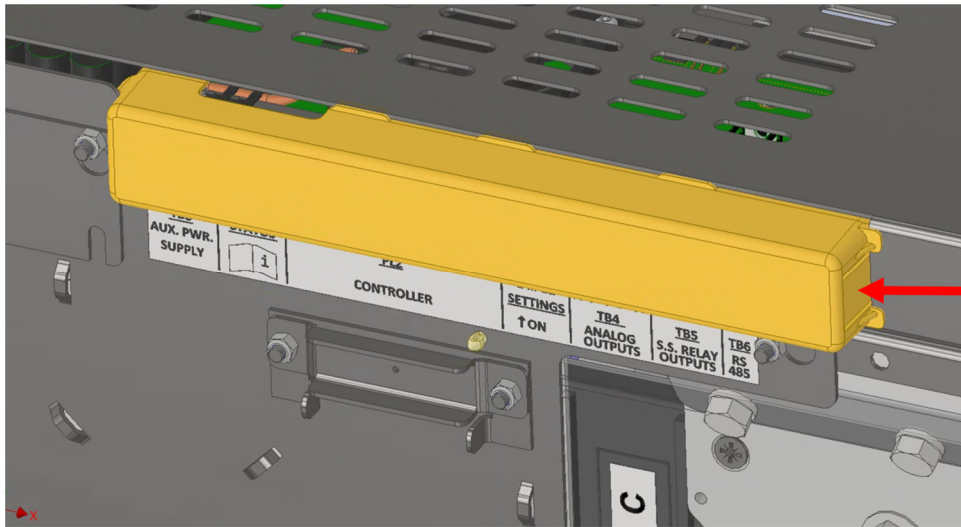

PRESS HERE TO
DISENGAGE PROTECTOR
FROM COVER

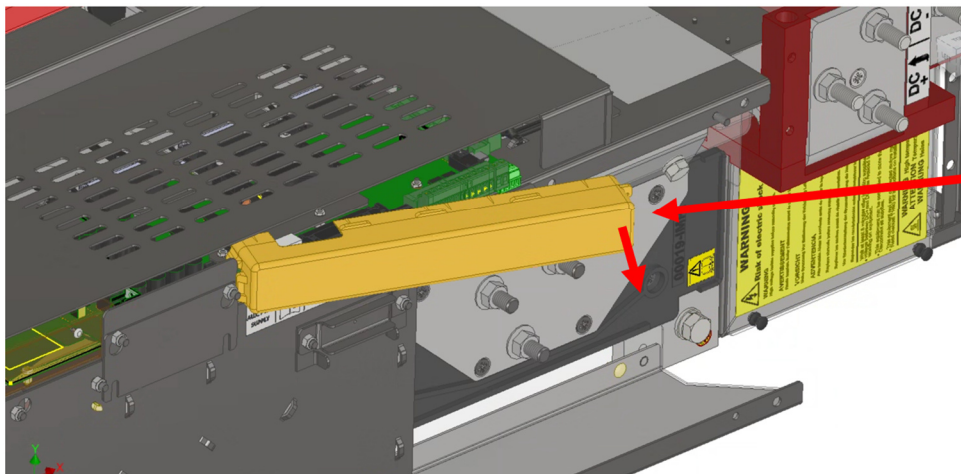

ROTATE PROTECTOR
AWAY FROM COVER AND
REMOVE

- This protector should be kept safe and re-fitted if it is ever necessary to remove the AEI unit.

5.4 TB3 – Auxiliary Power Supply

- Auxiliary power is generally provided to the AEI unit from an Avid Auxiliary Power Unit.
- For reference, the following gives more details of TB3:

Terminals	Function	Specifications and Notes
1	CONTROL POWER SUPPLY [+]	<ul style="list-style-type: none"> • Provides power for controller interface and IGBT drivers • 24V DC, +/-5%, 5A maximum load • Voltage transients during power on/off must be monotonic • Supply must meet application power loss ride-through requirements. • [-] terminals are connected to system 0V [GROUND] on the C.I.B.
3	CONTROL POWER SUPPLY [-]	
2	FAN POWER SUPPLY [+]	<ul style="list-style-type: none"> • Provides power for AEI internal cooling fans (when fitted) • 24V DC, +/-10%, 10A maximum load • Negative supply must be externally connected to system 0V [GROUND]
4	FAN POWER SUPPLY [-]	

- Customers wishing to provide their own auxiliary power should contact Avid Controls for further information and approval of proposed power supply equipment and connections. Customers **MUST NOT** use an unapproved auxiliary power scheme, doing so will void the product warranty.

5.5 TB4 – Analog Outputs

Terminals	Function	Specifications and Notes
1, 2, 3, 4	ANALOG OUTPUT A, B, C, D	<ul style="list-style-type: none"> • Analog outputs for user diagnostic monitoring • See section 6.3 for details on selecting specific signals to be output via analog outputs. • Range is +/-10V • Maximum load current is 5mA • Output source impedance is 50 Ω • Maximum error at all outputs is +/- 1% of full range with zero load • Pin 5 (0V – GND) is connected to system 0V [GROUND] on the C.I.B.
5	0V (GND)	

5.6 TB5 – Solid State Relays

Terminals	Function	Specifications and Notes
1, 2	SS RELAY A	<ul style="list-style-type: none"> Inverter module fault indication Relay energized indicates no fault condition Relay de-energized indicates a fault condition
3, 4	SS RELAY B	<ul style="list-style-type: none"> Internal cooling fan fail indication Relay energized indicates internal cooling fans are operating normally Relay de-energized indicates internal cooling fans are operating below minimum speed Under high load conditions, the unit will trip with a fan fail fault. See section 7.6 for details
		<ul style="list-style-type: none"> Maximum operating voltage is 60Vdc / 40Vac(rms) Maximum load current is 0.4A Typical ON resistance is 0.5 Ω NOT overload (short-circuit) or overvoltage protected For reference, on-board device is <i>Panasonic AVQ202A</i> or <i>AVQ252GA</i> solid-state relay.

5.7 TB6 – RS485

- The AEI inverter has a single 2-Wire RS485 (5V) port at TB6.
- See section 8, MODBUS Communications for a complete functional description of the operation of the RS485 port.
- If bus termination is required, an internal 120 Ω resistor can be connected across the DATA wires by connecting pins 1 & 2 of TB6.
- This port is fully isolated and has its own reference zero volts. ***Note that the isolation is provided for signal integrity and is not specified as a safety isolation barrier. All conductors on the RS485 connector must be maintained at safe low voltages.*** For signal integrity purposes, the isolation is rated at a minimum of 1500VDC.

- The pin out of this is:

Terminal	Function	Notes
1	TERM+	<ul style="list-style-type: none"> • One end of a 120 Ω resistor • The other end is internally connected to the DATA- signal • To terminate the RS485 bus at an AEI unit, connect this terminal to the DATA+ terminal (connect together pins 1 & 2)
2	DATA+	<ul style="list-style-type: none"> • RS485 (5V) 2-Wire data
3	DATA-	
4	RS485 0V	<ul style="list-style-type: none"> • This is the reference ground of the RS485 signals • It is not connected to system 0V (GROUND) • All RS485 0V connections (including the master device) should be connected for correct operation of the RS485 network

5.8 PL2 – Controller Connection

- Standard 40-way ribbon cable header for connection to a CDC.

6. User Selectable Options

6.1 Overview

- There are several options for the inverter unit that must be configured.
- These are configured using a set of 12 DIP switches on the C.I.B.
- These switches are numbered from 1 to 12, the ON position is towards the PCB itself, and the OFF position is towards the edge of the board.
- An additional set of 4 DIP switches is located adjacent to TB6 to configure the RS485 communications port. See section 8 for details.
- The DIP switches are very small, so a fine point instrument is needed to set them correctly.
- The default options are identified in the following descriptions.

6.2 Over-volts Trip Mode (SW1 to SW4)

- The overvoltage thresholds and delays are configured by SW1 to SW4.
- The following table defines the operation of these switches:

SWITCH SETTINGS				DC Link Voltage Trip Instant	DC Link Voltage Trip Delayed	Delay Time	Notes
SW 1	SW 2	SW 3	SW 4				
OFF	OFF	OFF	OFF	1188 Vdc	None	N/A	Legacy behavior for non-renewable energy systems
OFF	OFF	OFF	ON	1262 Vdc	1188 Vdc	0.5s	Units configured in one of these modes are used in position 1 of the system. <i>Default is 1s delay.</i>
OFF	OFF	ON	OFF			1.0s	
OFF	OFF	ON	ON			1.5s	
OFF	ON	OFF	OFF			2.0s	
OFF	ON	OFF	ON			2.5s	
OFF	ON	ON	OFF			3.0s	
OFF	ON	ON	ON			3.5s	
ON	OFF	OFF	OFF			4.0s	
ON	OFF	OFF	ON			4.5s	
ON	OFF	ON	OFF			5.0s	
ON	OFF	ON	ON			5.5s	
ON	ON	OFF	OFF			6.0s	
ON	ON	OFF	ON			6.5s	
ON	ON	ON	OFF			7.5s	
ON	ON	ON	ON	1290 Vdc	None	N/A	This mode may be used in positions 2 to 6 of a parallel inverter system.

6.3 Analog Output Mode (SW5 and SW6)

- The unit provides four analog outputs for system monitoring / debugging.
- See section 5.5 for electrical specifications.

- Scaling of different signal types is as follows:

Signal Type	Scaling
Current	<ul style="list-style-type: none"> • +/- 10 V output is equivalent to +/- 2500A • Positive values are defined as positive current OUT of the AC terminals of the unit. • When the output mode is rectified phase currents, only positive values will be output. • The formula for rectified mode is: Output = MAXIMUM (Ia , Ib , Ic).
DC Link Voltage	<ul style="list-style-type: none"> • 0 to +10V is equivalent to 0 to 1500 Vdc
Temperature	<ul style="list-style-type: none"> • 0 to +10V is equivalent to 0 to 150°C • Note that due to the nature of the internal temperature sensor, any temperature below 30°C will be indicated as 30°C.

- The signals that are output are controlled by DIP switches **SW5 & SW6**

Switch Positions		Mode	Analog Channel Outputs			
SW5	SW6		A	B	C	D
OFF	OFF	MIXED	Full wave rectified AC currents	Maximum IGBT module temperature	Minimum IGBT module temperature	DC Link Voltage
ON	OFF	CURRENTS	A phase AC current	B phase AC current	C phase AC current	
OFF	ON	TEMPS.	A phase IGBT module temperature	B phase IGBT module temperature	C phase IGBT module temperature	
ON	ON	UNUSED	Undefined value between -10V and +10V			

- **The default mode is MIXED.**

6.4 Compatibility Rating Mode (SW7)

- Certain models of Avid Extreme Inverter may be configured to report a lower rating to the controller than that of which they are capable.
- This feature is provided to support compatibility with legacy systems and to increase flexibility in different applications.
- Not all Avid Extreme Inverter units support a compatibility rating.
- Compatibility Rating Mode is enabled by setting DIP switch **SW7** to the ON position (its ***default is OFF***).
- The following table shows those modules that support this mode:

MODEL	Compatibility Rating (Reported to Controller) (DIP Switch SW7 = ON)
AEI900L	110% Overload Duty: 800A 150% Overload Duty: 587A
AEI1000L / AEI1250L / AEI1400L	No compatibility rating is supported. SW7 has no effect.

6.5 MODBUS Address Setup Switches

- These three switches set the MODBUS Slave Address of the AEI.
- These are SW1 to SW3 on the small DIP switch bank adjacent to TB6. Like the main DIP switch bank, these are numbered SW1 to SW4 from top to bottom when the unit is installed vertically in a cabinet.
- The functions are as follows:

SWITCH SETTINGS			MODBUS SLAVE ADDRESS	Notes
SW1 (RS485)	SW2 (RS485)	SW3 (RS485)		
OFF	OFF	OFF	1	As can be seen, the MODBUS slave address is <i>1 + SW[]</i> <i><u>The default is OFF OFF OFF</u></i> : Slave Address = 1
OFF	OFF	ON	2	
OFF	ON	OFF	3	
OFF	ON	ON	4	
ON	OFF	OFF	5	
ON	OFF	ON	6	
ON	ON	OFF	7	
ON	ON	ON	8	

- See section 8 for details of the MODBUS communication function.

6.6 MODBUS Sample Mode

SW4 (RS485)	Sample Mode	Notes
<i>OFF (Default)</i>	Standard Sample Mode	See section 8.4 for details
ON	Simultaneous Sample Mode	

6.7 Unused Switches













- SW8 through SW12 of the main switch bank currently have no assigned functions.
- ***They should be left in the OFF position to ensure compatibility with any future upgrades.***

7. LEDs and Fault Indication

- The unit has two discrete LED's (red and green) and a two-digit LED display.
- The discrete LEDs indicate the operational state of the unit and the numeric display may either indicate various feedback signals or all active faults.

7.1 Discrete RED & GREEN LEDs

 - OFF  - ON  - FLASHING

RED LED	GREEN LED	Meaning
		Auxiliary supply is not present
		Internal error present on C.I.B. or auxiliary supply is out of tolerance
		Unit healthy (not tripped) and disabled (IGBT's not switching)
		Unit healthy (not tripped) and enabled (IGBT's switching)
		Unit faulted. Fault codes will be displayed on 2-digit display, appropriate fault codes sent to controller (as supported – see section 7.5)
		Controller is attempting a reset cycle

7.2 Discrete YELLOW LED

- When illuminated, this indicates that a FAN FAIL condition exists and that, depending upon load current, a unit trip may occur in the future.
- See section 7.6 for more details on fan monitoring.

7.3 Program Version Display

- When the auxiliary power is applied, the 2-digit LED displays the C.I.B. program version for three seconds.
- This version is also displayed on a small label on the front of the unit. This information will be required by Avid when providing technical assistance.

7.4 LED Feedback Indication

- After power up, when the unit is not faulted, the 2-digit LED display cycles through indications of several operational feedbacks.
- Each feedback is displayed for 1s, before the display cycles to the next feedback. A "--" pattern is used to indicate the start of the cycle.
- The cycle is:



- "--"
- CURRENT - A PHASE
- CURRENT - B PHASE
- CURRENT - C PHASE
- TEMPERATURE – A PHASE IGBT
- TEMPERATURE – B PHASE IGBT
- TEMPERATURE – C PHASE IGBT
- TEMPERATURE – C.I.B.
- DC LINK VOLTAGE

- In a similar manner to the analog outputs, most values are displayed as the percentage of a defined value. The exception is the C.I.B. temperature which is displayed in °C.

Signal Type	Explanation & Scaling
Current	<ul style="list-style-type: none"> • 100% output is equivalent to 2500A • The formula for the indication is: <ul style="list-style-type: none"> ○ % CURRENT = 100% X AVERAGE_{1s} (Phase Current) / 2500A • Or, in words, the formula is <i>the absolute current averaged over 1s, expressed as a percentage of 2500A</i> • This will produce fluctuating display values at lower power frequencies as the 1s average period beats with the current waveform • For reference, the relationship between AVERAGE OF MEAN and RMS values for a sinusoid is AVERAGE = 0.90 X RMS
DC Link Voltage	<ul style="list-style-type: none"> • Average over 1s expressed as percentage of 1500 Vdc
IGBT Temperature	<ul style="list-style-type: none"> • Expressed as percentage of 150°C (0°C = 0%, 150°C = 100%) • Note that due to the nature of the internal temperature sensor, any temperature below 30°C will be indicated as 20%.
C.I.B. Temperature	<ul style="list-style-type: none"> • This is displayed in °C • Note due to absence of negative sign any value below 0°C will be displayed as '00'

7.5 Fault Codes

- When the unit has a fault, the 2-digit LED display cycles through a list of all active faults.
- Each fault that the unit recognizes is encoded into a compatible fault code for indication by the controller.
- The AEI unit can identify many more and different faults than the controller can recognize, so for each native AEI fault the most appropriate controller fault code is generated. This is detailed in the table below.
- All of the active fault codes can also be read via MODBUS – see section 8 for details.
- The following table describes each fault code on the unit, together with the fault code that is transmitted to the controller for each of the faults recognized by the C.I.B.:

Fault Code on LED Display	Meaning	Trip Code Transmitted to Controller* ¹
1	A Phase IGBT Self-Protect Fault	31
2	B Phase IGBT Self-Protect Fault	33
3	C Phase IGBT Self-Protect Fault	35
4	A Phase Heatsink Over Temperature Fault	32
5	B Phase Heatsink Over Temperature Fault	34
6	C Phase Heatsink Over Temperature Fault	36
7	A Phase Silicon Over Temperature Fault	32
8	B Phase Silicon Over Temperature Fault	34
9	C Phase Silicon Over Temperature Fault	36
10	Over Voltage (DC Link)	38
11	External Trip Fault	37
12	Internal Fan 1 Failure (on units where this fan is fitted)	243
13	Internal Fan 2 Failure (on units where this fan is fitted)	243
14	Internal Fan 3 Failure (on units where this fan is fitted)	243
15	External Fan Failure (on units where this fan is fitted)	243
16	Incoming Power Supply Fault	240
17	Internal Power Supply Fault (+15V)* ²	241
18	Internal Power Supply Fault (-15V)* ²	242
19	Internal Power Supply Fault (IGBT)* ²	240
20	Internal Power Supply Fault (+3V5)* ²	240
21	Internal PWM Deadtime Fault (A Phase)* ²	247
22	Internal PWM Deadtime Fault (B Phase)* ²	248

Fault Code on LED Display	Meaning	Trip Code Transmitted to Controller ^{*1}
23	Internal PWM Deadtime Fault (C Phase) ^{*2}	249
24	Internal PWM Frequency Fault (A Phase) ^{*2}	244
25	Internal PWM Frequency Fault (B Phase) ^{*2}	245
26	Internal PWM Frequency Fault (C Phase) ^{*2}	246
27	A Phase Positive Instantaneous Overcurrent	31
28	A Phase Negative Instantaneous Overcurrent	31
29	B Phase Positive Instantaneous Overcurrent	33
30	B Phase Negative Instantaneous Overcurrent	33
31	C Phase Positive Instantaneous Overcurrent	35
32	C Phase Negative Instantaneous Overcurrent	35
33	DC Link Feedback Fault ^{*2}	212
34	Internal Fault ^{*2}	212
35	Interface Board Over Temperature (65°C)	212
36	Internal Data Error ^{*3}	212

***1:** The fault code for a unit connected to position 1 of the controller system is given. For units in other positions the equivalent fault code will be displayed by the controller.

***2:** These faults indicate a fault within the inverter unit. They do not occur in normal operation and user fault-finding is generally not possible. In the unlikely event that these faults are experienced, contact Avid Controls for support.

***3:** This fault can happen if the connected CDC (controller) makes an incomplete attempt to reprogram the internal data. Reprogramming is possible with access to the controller’s maintenance features.

7.6 Internal Cooling Fan Fault

- AEI units with internal cooling fans continually monitor the fans' speed and take action if they drop below minimum speed.
- Certain AEI900L and AEI1000L models do not have internal cooling fans. In these cases, the user **MUST** implement external capacitor cooling fans for the unit. These external fans are **NOT** monitored by the unit and their failure may result in failure of the unit. If you are using AEI900L or AEI1000L units without internal fans, it is highly recommended that you contact Avid Controls for additional technical support.
- All units immediately indicate fan failure via SS RELAY B, see section 5.6 for details.
- After a load dependent delay, the unit will fault, indicating the appropriate fault code from section 7.5.
- The following figure shows the fault delay time as a function of the load current:

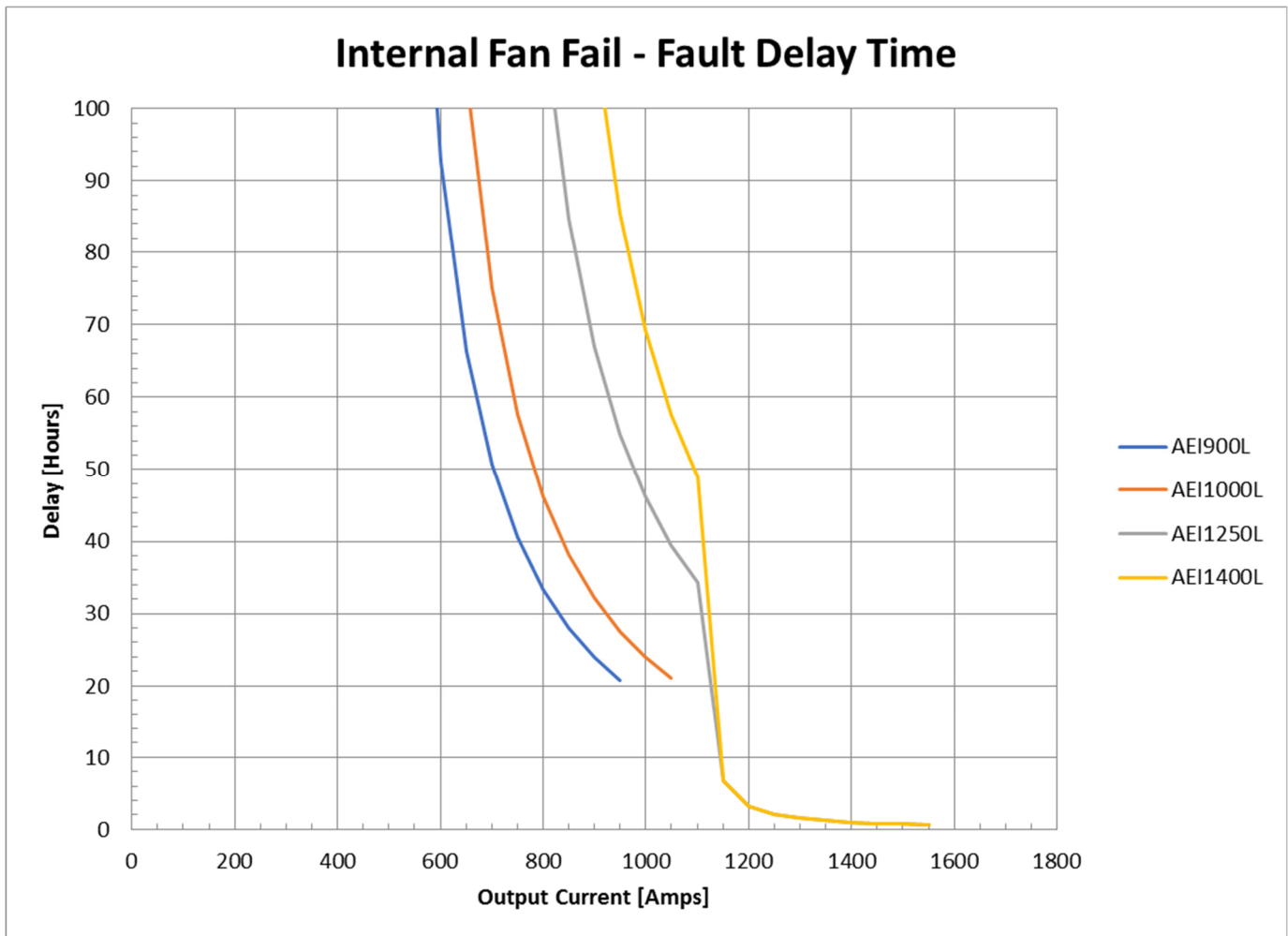

8. MODBUS¹ Communications

8.1 Introduction

- The AEI implements a small subset of the MODBUS RTU SLAVE PROTOCOL via the 2-wire (plus ground) RS485 port on TB6.
- The port has the following electrical and data specifications:
 - Electrical Levels: TIA/EIA RS485, 5V
 - Isolation: Fully isolated for signal integrity
Maximum isolation voltage (*not for safety*) is 1500V
 - Baud Rate: 115200 bits per second
 - Parity: None
 - Data Bits: 8
 - Stop Bits: 1
 - Termination: An internal 120Ω termination resistor may be connected across the RS485 data wires by linking TB6/1 to TB6/2

8.2 MODBUS_TIMER

- The AEI maintains a 1ms timer, **MODBUS_TIMER**, that counts continuously and overflows from 65535 to 0 every 65.536 seconds.
- The value of **MODBUS_TIMER** is one of the diagnostic fields that is provided via the MODBUS link.
- The following MODBUS function is used to synchronize **MODBUS_TIMER** between all AEI's connected to the MODBUS network:
 - MODBUS Address: 00 (Global Address)
 - MODBUS Function: 06 – Write Single Register
 - Register Address: 0
 - Write Data: The required value for **MODBUS_TIMER**.
Data is loaded immediately (< 1ms) into **MODBUS_TIMER** by all AEI's that validate the received message

8.3 Diagnostic Data

- The AEI will transmit 32 words of diagnostic data in response to a MODBUS query.
- The following MODBUS function is used to read diagnostic data from the AEI:
 - MODBUS Slave Address: 01 to 08, switch selectable
 - MODBUS Function: 03 – Read Holding Registers
 - Base Register Address: 0
 - Read Length: 32

¹ MODBUS is a registered trademark of Schneider Automation Inc.

- The following table defines the diagnostic data that is transmitted:

REG.	NAME	TYPE	NOTES
0	SER_NUM	UNSIGNED	This is the AEI serial number. Does not change.
1	TIMER	UNSIGNED	Free running <i>1ms</i> timer that can be written using MODBUS Global Address – see section 8.2. Sampled when read.
2	FAULT_1_16	BIT FIELD	BIT 0 is FAULT_1 BIT 15 is FAULT_16
3	FAULT_17_32	BIT FIELD	BIT 0 is FAULT_17 BIT 15 is FAULT_32
4	FAULT_33_48	BIT FIELD	BIT 0 is FAULT_33 BIT 15 is FAULT_48
Each bit of these <i>bit fields</i> indicates if the fault designated by the equivalent code is active. See section 7.5 for list of fault codes. Sampled when read.			
5	FAN_1_SPEED	UNSIGNED	The speed, in <i>RPM</i> , of the internal cooling fans. Sampled when read.
6	FAN_2_SPEED	UNSIGNED	Note that the AEI detects a fault if these speeds fall below safe values (the exact value varies based upon a number of factors). See section 7.6 for details.
7	FAN_3_SPEED	UNSIGNED	These are provided to allow the user to compare speeds <i>between</i> AEI's and with <i>historical</i> values, giving the possibility of identifying a unit with a fan problem prior to failure.
8	MAX_POS_CURRENT_A	SIGNED	The maximum positive current, in <i>AMPS</i> , of each output phase of the AEI, since the diagnostic data was last transmitted. This will be a positive value.
9	MAX_POS_CURRENT_B	SIGNED	
10	MAX_POS_CURRENT_C	SIGNED	
11	MAX_NEG_CURRENT_A	SIGNED	The maximum negative current, in <i>AMPS</i> , of each output phase of the AEI, since the diagnostic data was last transmitted. This will be a negative value.
12	MAX_NEG_CURRENT_B	SIGNED	
13	MAX_NEG_CURRENT_C	SIGNED	
14	AVG_CURRENT_A	SIGNED	The average absolute current, in <i>AMPS</i> , of each output phase of the AEI, since the diagnostic data was last transmitted.
15	AVG_CURRENT_B	SIGNED	Note that the current is first rectified before the average is calculated, so that positive or negative output currents are not differentiated.
16	AVG_CURRENT_C	SIGNED	Note that (due to storage limits) the evaluation of average is suspended after 32767 PWM periods of evaluation (13s at 2.5kHz PWM). So to utilize this data, it must be accessed at least this often.
17	IGBT_TEMP_A	SIGNED	The temperature, in <i>0.1°C</i> units, of the IGBT temperature feedback devices. Sampled when read.
18	IGBT_TEMP_B	SIGNED	
19	IGBT_TEMP_C	SIGNED	
20	MAX_IGBT_TEMP_A	SIGNED	The maximum temperature, in <i>0.1°C</i> units, of the IGBT temperature feedback devices since the diagnostic data was last read.

REG.	NAME	TYPE	NOTES
21	MAX_IGBT_TEMP_B	SIGNED	
22	MAX_IGBT_TEMP_C	SIGNED	
23	CIB TEMPERATURE	SIGNED	The CIB temperature in <u>1°C</u> units. Sampled when read.
24	DC_VOLTS	SIGNED	The current value, in <u>0.1V</u> units, of the measured DC link voltage. Sampled when read.
25	MAX_DC_VOLTS	SIGNED	The maximum value, in <u>0.1V</u> units, of the measured DC link voltage since the diagnostic data was last read.
26	STATUS	BIT FIELD	BIT 0: TRIPPED
			BIT 1: ENABLED
			BIT 2: FAN FAIL
			OTHER BITS: ZERO
27	SENSOR 1	UNSIGNED	The AEI has three internal sensors, CURRENTLY UNUSED, able to measure 0-10V signals from a variety of optional sensors. These registers give the sensor values, in <u>1mV</u> units. Sampled when read.
28	SENSOR 2		
29	SENSOR 3		
30	UNUSED	UNSIGNED	These words are stuck at ZERO.
31			

8.4 MODBUS Sample Mode

Standard Mode (RS485 SW4 OFF)

- In this mode, the data to be transmitted in response to a MODBUS query is sampled as soon as a valid query, addressed to the slave address set by SW1 to SW3, is received.
- Once sampled, data is transmitted immediately.

Simultaneous Sample Mode (RS485 SW4 ON)

- In this mode, the data to be transmitted is sampled when a valid MODBUS query *addressed to slave address 01* is detected, independent of the slave address set by SW1 to SW3.
- The sampled data is not transmitted until a valid MODBUS query, addressed to the slave address set by SW1 to SW3, is received.
- In this mode, all AEI's on a single bus will sample their data simultaneously.
- Things to note:
 - This switch has no effect on the AEI configured to be slave address 01.
 - If slave address 01 is not polled by the MODBUS master, then no data will be sampled by any unit on the bus.
 - If a data error occurs on one of the units being commanded to sample, it will not do so but no MODBUS exception will be created. This circumstance should be vanishingly rare and may be detected by incoherent MODBUS TIMER data in the transmitted response.

9. Contact Details: Sales, Service and Support

Avid Controls Inc.
41261 Park 290 Drive, Waller, TX 77484, USA
info@avidcontrolsinc.com (+1) (281) 640-8600

10. Document Revision History

Rev.	Date	Author	Changes
00	Nov. 14 2023	Gary Pace / Mark Woods	Document created from DTS-MID0012-REV_15
01	June 10 2024	Mark Woods	Correction of Staubli type from RMI to RME
02	June 4, 2025	Mark Woods / Gary Pace	AEI1250L & AEI1400L incorporated into document. Analog output source impedance corrected.

11. Appendix A – Application Information

- This appendix provides additional information to allow the safe application of AEI900L and AEI1000L modules.

11.1 Introduction to Application Concepts

- The AEI900L / AEI1000L / AEI1250L / AEI1400L are liquid cooled power modules which can be defined as the Converter section of the Basic Drive Module of the Power Drive System as defined in UL 61800-5-1.
- They can be used to power motors in various applications including general industrial use and marine propulsion.
- The AEI modules can also be used as part of a sinusoidal four quadrant converter for AFE applications such as wind turbine converters.
- The Avid Extreme Inverter modules can be connected in parallel to provide a wide range of power levels.
- In relation to the PDS diagram defined in UL 61800-5-1, the AEI module provides the heart of the Converter Section of the BDM. The Control Section is separate from the AEI and interfaces to it via a 40-way ribbon cable. Avid provide a range of Auxiliaries such as compatible power supplies.

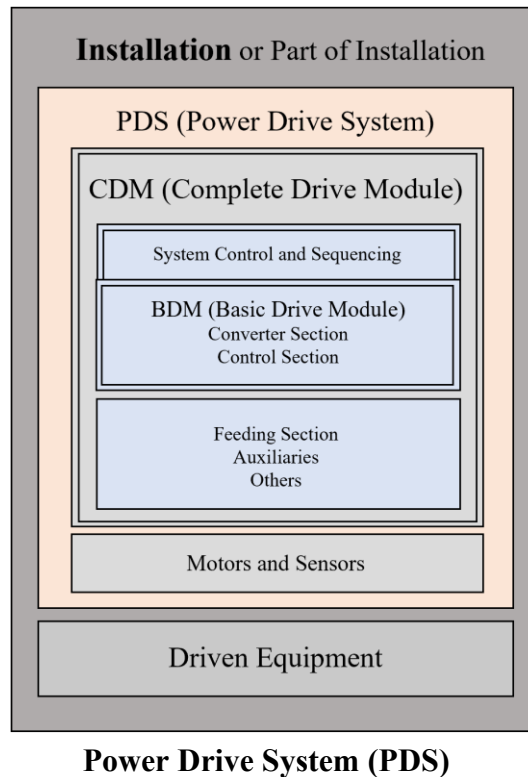

11.2 Liquid Cooled Avid Extreme Inverter Modules

- Avid Extreme Inverter (AEI) modules are used in Variable Frequency Drives in both Diode Front End (DFE) and Active Front End (AFE) and can perform AC→DC or DC→AC conversion.
- A wide range of AEI models are available from Avid Controls. This manual covers the AEI900L / AEI1000L / AEI1250L / AEI1400L modules which have current ratings of 900A / 1000A / 1250A and 1400A respectively.

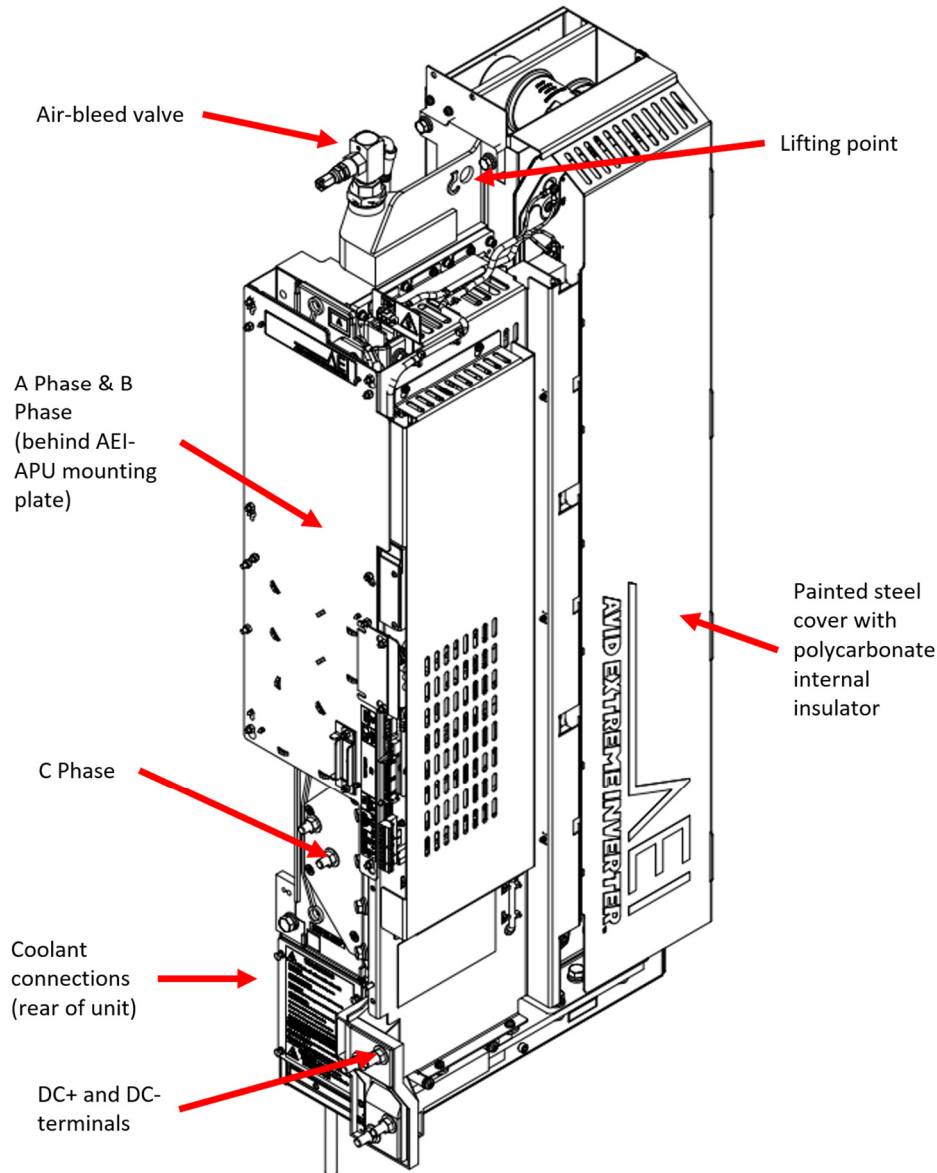

Figure 11-1. AEI Module Overview

- The Avid Extreme Inverter contains three high powered SKiiP®4 IGBT devices mounted on an aluminum duct with an integral DC capacitor bank (each SKiiP also contains protection flywheel diodes).
- The AEI contains an interface PCB mounted on the module. This is known as the Controller Interface Board or CIB which enables the AEI to be used as part of the MV3000 range of AC drives, controlled by the Common Drive Controller (CDC). The CIB also measures the DC link voltage and contains other interface circuitry such as communications and digital/analog outputs used for fault indication and monitoring.
- A large DC capacitor bank forms part of the AEI and connects to the IGBTs via a low impedance bus known as the DC laminate. There are two sizes of capacitor bank dependent on AEI model and discharge resistors are provided mounted on the underside of the aluminum casting duct. To achieve the voltage rating of the DC link, the capacitor bank has multiple, parallel paths of capacitors connected in series. The discharge resistors also act to ensure balanced voltage across the capacitors.
- Three AC terminals are provided on the front of the AEI, each containing two (900A) or three (1000A / 1250A / 1400A) M10 studs for cable connection.
- Two DC terminals are provided at the base of the module for DC+ and DC-. Each terminal has either two (900A) or three (1000A / 1250A / 1400A) M10 studs for cable connections.

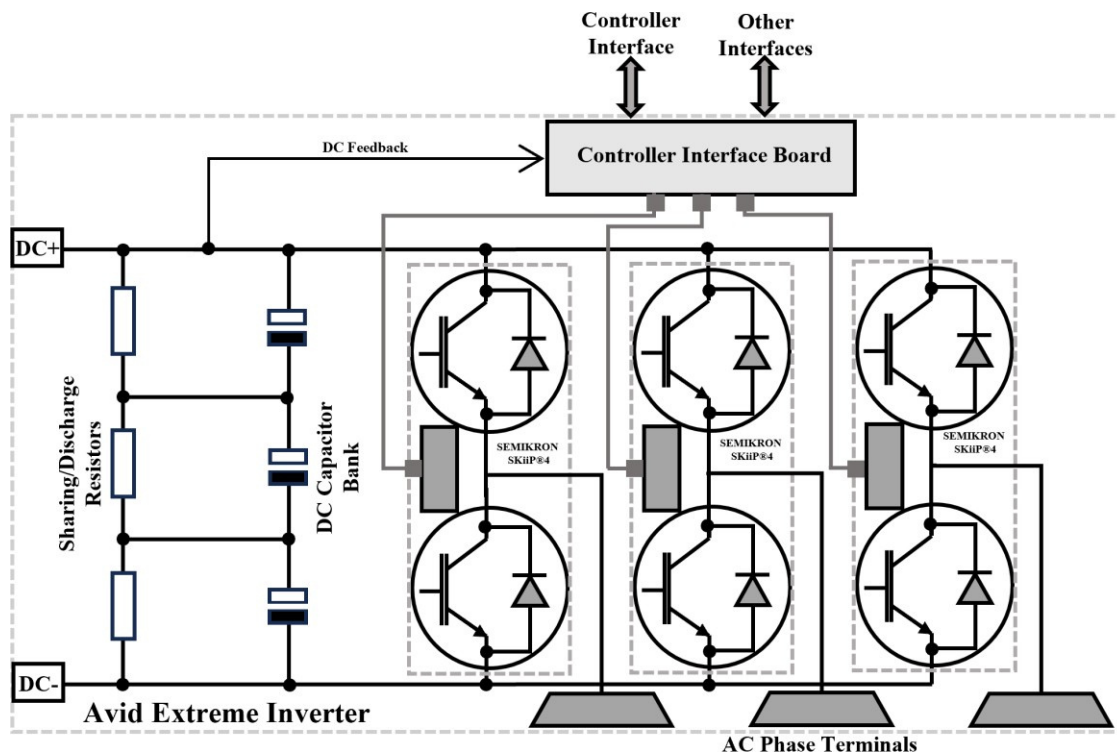

Figure 11-2. AEI Module Schematic

11.3 Variable Frequency Drive Topologies

11.3.1 Diode Front End (DFE)

- This type of drive allows power flow in one direction only. Using a diode rectifier to convert the three phase AC voltage the resulting DC link is inverted back to AC using the AEI module as an output bridge to the motor. The 6-pulse DFE uses a single 3-phase rectifier which produces excessive supply harmonics. These can be reduced using a 12-pulse DFE configuration requiring two rectifiers fed from a phase shift transformer.

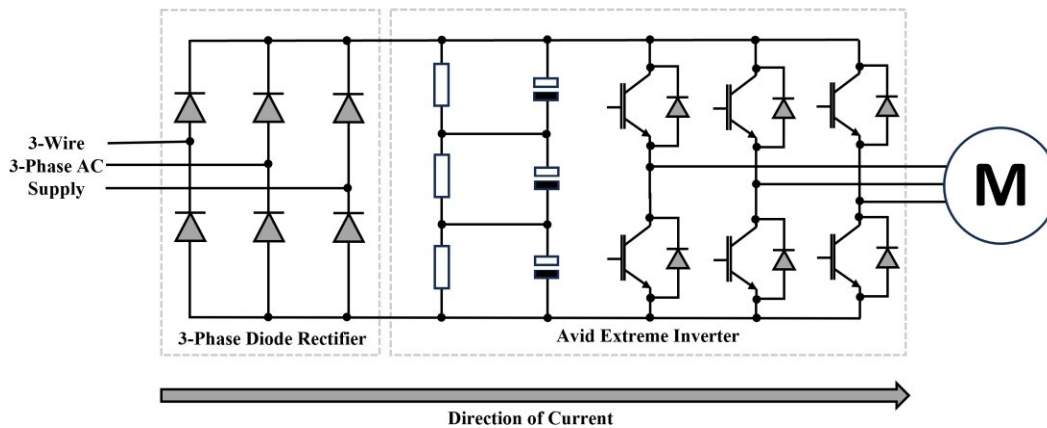

Figure 11-3. Power section of a 3-phase DFE converter

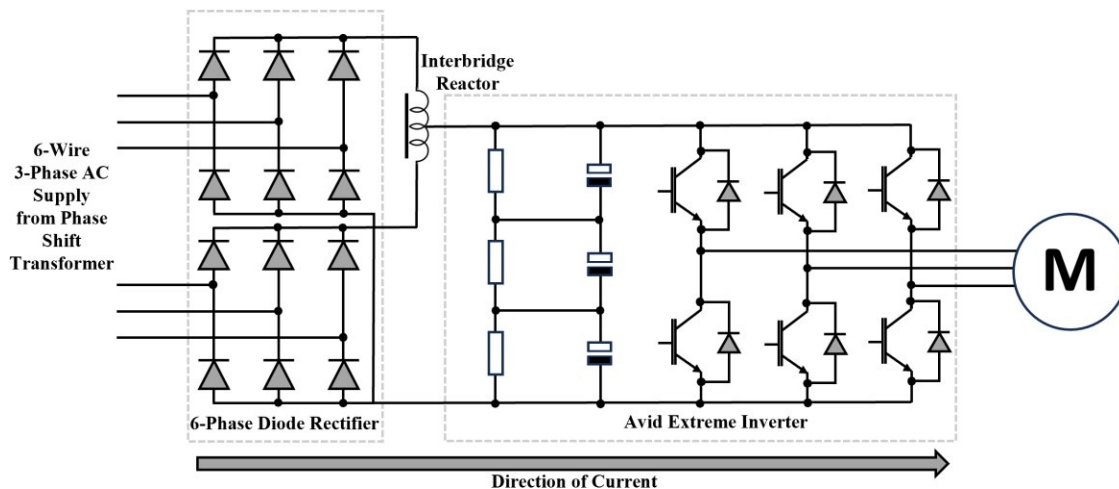

Figure 11-4. Power section of a 6-phase DFE converter

11.3.2 Active Front End (AFE)

- This drive allows power flow in both directions to and from the network and machine bridge. The AFE is useful for regenerative loads such as cranes and hoists. Using Insulated Gate Bipolar Transistors (IGBTs) instead of a diode front end the AFE monitors the input current waveform and shapes it to be sinusoidal, reducing total harmonic distortion (THD). The AFE configuration is also required in applications such as wind turbines where the variable voltage and frequency produced by the generator is required to be converted into a fixed voltage and frequency supply required by the network grid.

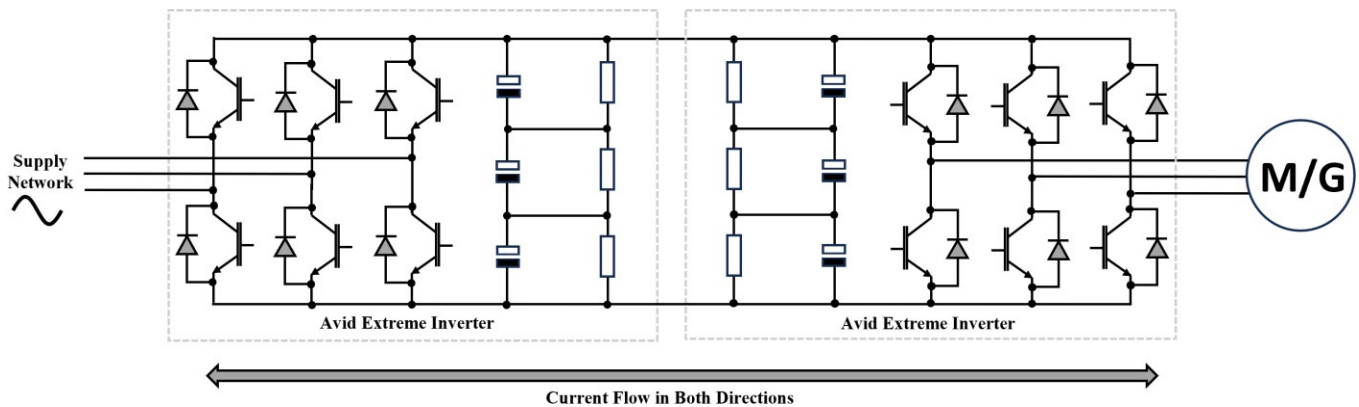

Figure 11-5. Power section of an AFE converter

11.4 Integrating the AEI into the Power Drive System

- The system designer must provide additional components in order to produce the complete Power Drive System (PDS):
- Supply Fuses – Suitably rated for the application and with fuse failure indication.
- Pre-Charge Circuit – A method of charging the DC link capacitors in a controlled manner via resistors to prevent excessive inrush currents. When pre-charge is complete, this circuit is bypassed. In the AFE, the DC pre-charge supply is often derived from the flywheel diodes in the IGBTs. The pre-charge circuit must be protected by suitably rated fuses rated only for the pre-charge current.
- Supply Reactor & PWM Filter – These components work together to filter out the high- frequency noise generated by the Pulse Width Modulation (PWM) switching noise generated by the converter which would otherwise affect the supply. The reactor is required to be rated at
- The full current of the PDS. The PWM filter will be designed for the main PWM frequency and significant harmonics.

- For parallel operation of two or more AEI modules, output sharing reactors are recommended on the AC output. These will generally be iron cored three phase reactors with inductance of 10uH and rated for the AEI output current and with Class H temperature rise. Contact Avid for available sharing reactors.

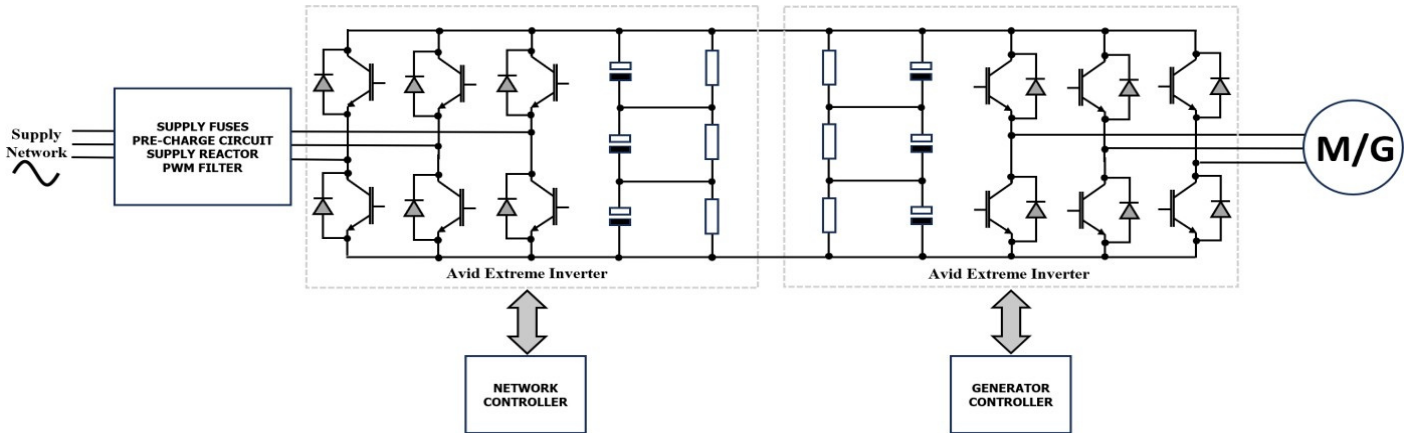

Figure 11-6. Example schematic of AEI modules integrated into the PDS

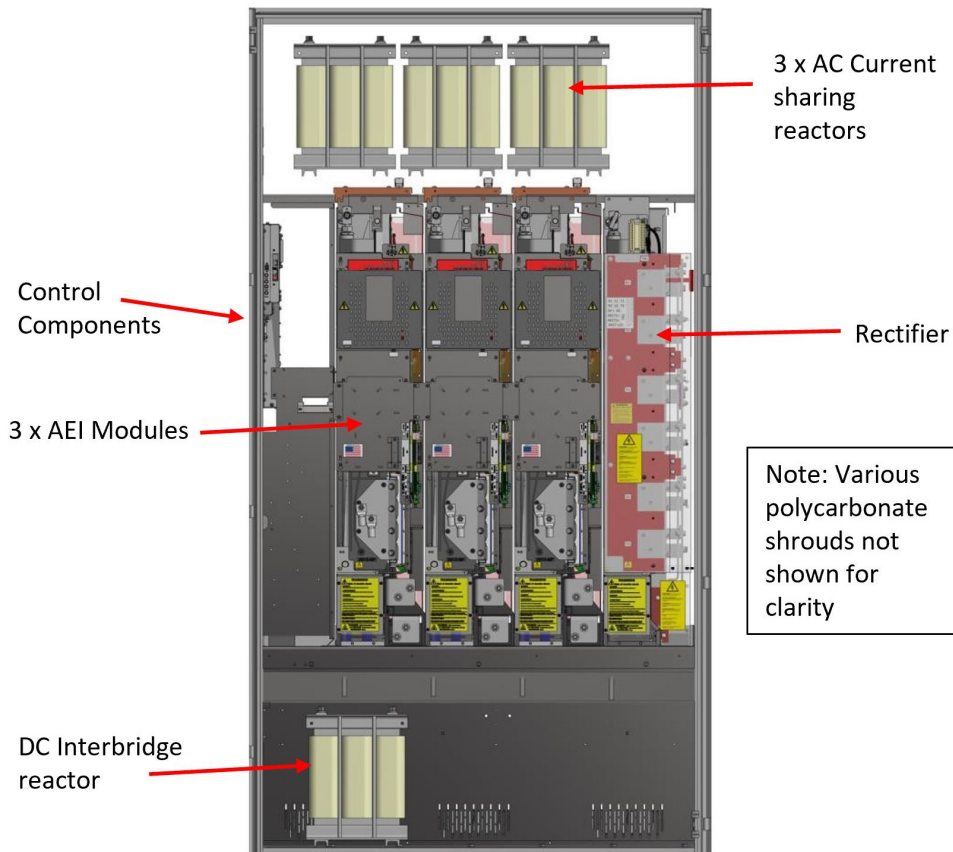

Figure 11-7. Example of general arrangement of a DFE drive

11.5 Installation

11.5.1 Enclosure/Cabinet Information

- The Basic Drive Module (BDM) consisting of the Avid Extreme Inverter (AEI) modules, auxiliary power units (APUs), controller, rectifier, etc. must be fitted into an enclosure.
- The size of the enclosure is dependent on the number of AEI modules.
- Rittal VX25 basic enclosures are recommended, e.g., VX 8806.000 (H 1800mm x W 600mm x D 600mm) and VX 8208.000 (H 2000mm x W 1200mm x D 800mm).
- The MINIMUM depth of an enclosure is 600mm for clearance of the modules to the front and back.
- The following compatible cubicle mounting accessories are available from Avid:

Description
Cross Rail Lower Front, VX25 800mm Wide Cubicle (8806.000)
Cross Rail Lower Rear, VX25 800mm Wide Cubicle (8806.000)
Guide Plate Lower, VX25 800mm Wide Cubicle (8806.000)
Guide Plate Upper, VX25 800mm Wide Cubicle (8806.000)
Cross Rail Lower Front, VX25 1200mm Wide Cubicle (8208.000)
Cross Rail Lower Rear, VX25 1200mm Wide Cubicle (8208.000)
Guide Plate Lower, VX25 1200mm Wide Cubicle (8208.000)
Guide Plate Upper, VX25 1200mm Wide Cubicle (8208.000)
Side Rail, VX25 800mm Wide Cubicle (8806.000)
Side Rail, VX25 1200mm Wide x 800 Deep Cubicle (8208.000)

11.5.2 Fitting the Avid Extreme Inverter

- Fit guide rails, cross rails etc. into the enclosure as shown:
- The type of guide rails needed depends on the size of the enclosure and number of modules.

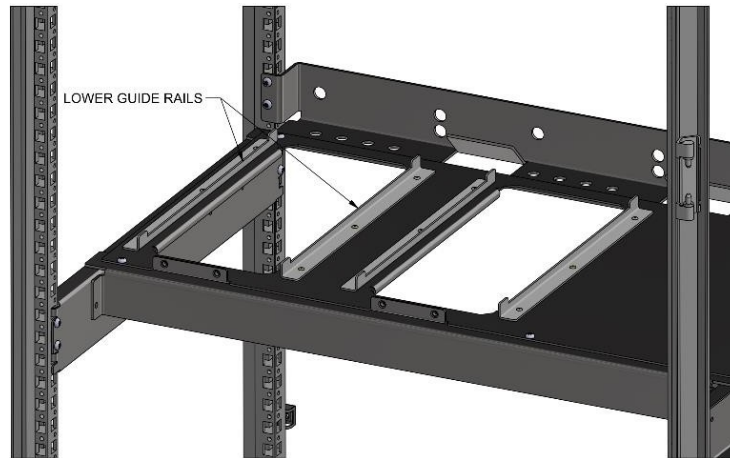

Figure 11-8. AEI mounting rails

- The module is heavy and **MUST** be positioned into the enclosure using suitable lifting equipment rated for the weight of the module:
 - 105kg/231 lb. for AEI900L/AEI1000L
 - 125kg/276 lb. for AEI1250L/AEI1400L
- The lifting eye is located at the top of the module and marked with a hook symbol.

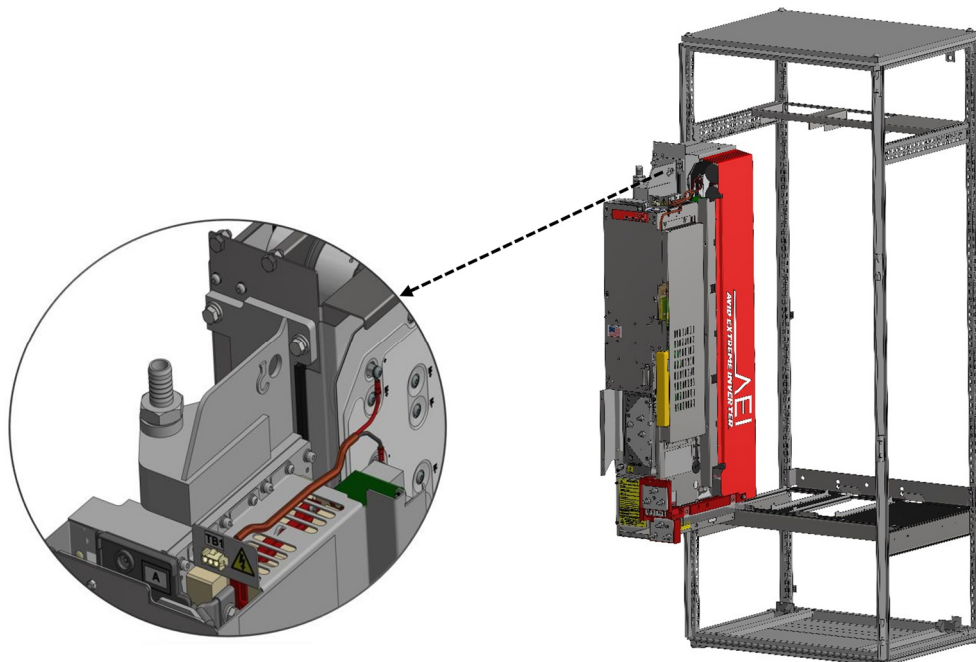

Figure 11-9. Location of lifting eye

- Using the lifting equipment raise the AEI module so that its base is level with the lower guide plate.
- Locate the bottom of the module between the lower guide rails.
- When engaged slide the module backwards into the enclosure.
- When the top of the AEI module engages with the upper guide rails the lifting hook can be detached.

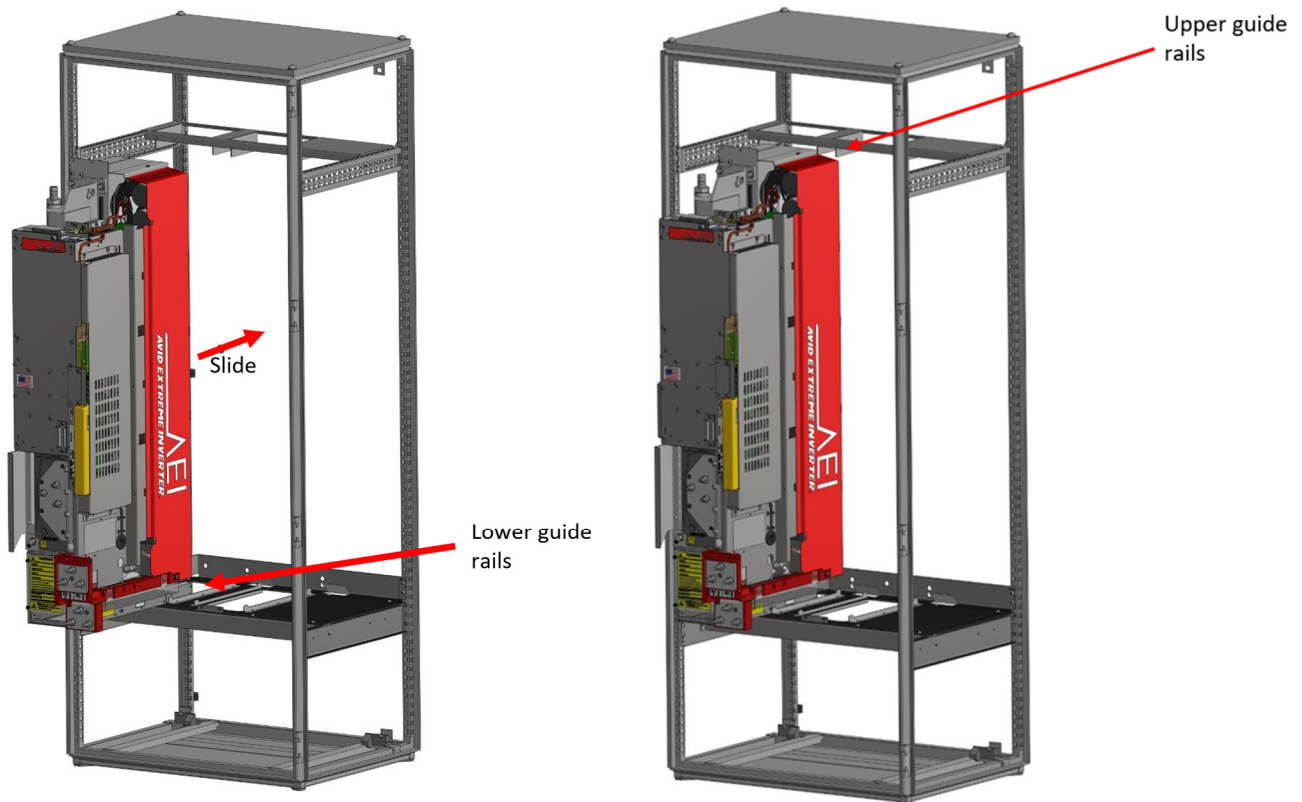

Figure 11-10. AEI engages with lower and upper guide rails

- Slide the AEI Module in the direction shown until fully home.

- Secure the AEI module to the top rail using 2 x M5x10 Taptite screws.
- Secure to the lower mounting rail using 2 x M6x16 hex bolts, flat and spring washers.

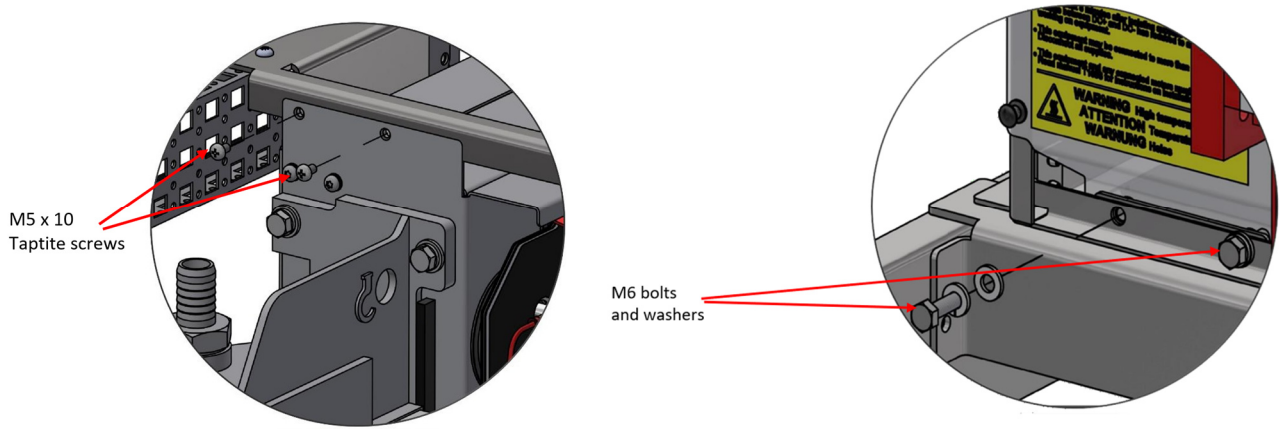

Figure 11-11. Securing fasteners (top and bottom)

11.6 Protection Requirements

11.6.1 Access

WARNING

- The AEI module is of IP00 construction and **MUST** always be installed in an enclosure with restricted access.
- Additional protection against accidental contact is provided in the form of polycarbonate covers (shrouds) for the AC and DC terminals. The AEI module must only be powered when these shrouds are fitted, and the enclosure doors are closed and secured. There is no protection at the rear of the module as this would not be accessible when fitted in the enclosure.
- Yellow warning labels on the AEI module instruct users to wait for 8 minutes after power is removed before working on the equipment (this is to allow DC link energy to discharge to a safe voltage).

11.6.2 Low Voltage Circuits

- The entire low voltage section of the AEI-CIB is considered to be Safety Extra Low Voltage (SELV).
- All circuits in the low voltage area are referenced to the chassis ground (earth) of the inverter unit assembly.
- This separation is achieved via the isolation barrier within the Auxiliary Power Unit (APU). For this reason, only Avid supplied APUs **MUST** be used to power the 24V input to the AEI module.

11.6.3 Fuses

- The fusing requirements depend on the system configuration. Fuses must have sufficient voltage rating for the application and have fuse failure indication. Typical fuses would include the Bussman, Mersen (Ferraz Shawmut), etc. high speed, square body range.
- DFE System - Fusing must be provided on the input side of each rectifier providing the DC link for the AEI modules. Output short circuit is provided by the AEI (Electronic protection provided in each IGBT).
- Single AEI AFE System - Semiconductor fuses should be fitted on the AC supply to the AEI module.
- Multiple AEI AFE System - Semiconductor fuses should be fitted on the AC supply to each AEI module and also to the DC output of each AEI. Note that fusing is required for both DC+ and DC- i.e., two fuses per AEI module.
- The following fuses are recommended:

AEI Type	Inverter Application Duty / Rating	Recommended AC Fuses
AEI900L	DC Voltage \leq 1200V DC Current 1098A / AC Current 900A (+10% Overload 60s once per 10 minutes) or DC Current 805A / AC Current 660A (+50% Overload 60s once per 10 minutes)	Rating: 1000A Eaton Bussmann 170M6114 Mersen PC33UD69V1000A
AEI1000L	DC Voltage \leq 1200V DC Current 1220A / AC Current 1000A (+10% Overload 60s once per 10 minutes) or DC Current 894A / AC Current 733A (+50% Overload 60s once per 10 minutes)	Rating: 1250A Eaton Bussmann 170M6116 Mersen PC33UD69V1250A
AEI1250L	DC Voltage \leq 1200V DC Current 1525A / AC Current 1250A (+10% Overload 60s once per 10 minutes) or DC Current 1118A / AC Current 916A (+50% Overload 60s once per 10 minutes)	Rating: 1400A Eaton Bussmann 170M6117 Mersen PC33UD69V1400A
AEI1400L	DC Voltage \leq 1200V DC Current 1708A / AC Current 1400A (+10% Overload 60s once per 10 minutes) or DC Current 1252A / AC Current 1026A (+50% Overload 60s once per 10 minutes)	Rating: 1600A Eaton Bussmann 170M6119 Mersen PC33UD60V1600A* NOTE* Fuse is rated at 600V AC IEC / 650V AC UL

- Suggested microswitches for the fuses:
 - Eaton Bussman Microswitch - 170H0069.
 - Mersen Microswitch - MS3V1-5.
- Suitable fuse holders can be chosen from the manufacturers' catalogs.

11.6.4 Motor Overload & Thermal Protection

- Motor protection is provided by the MV3000 Common Drive Controller and the I/O Module connected to the AEI. The following section details settings in the controller in order to provide comprehensive motor protection.
- The following sections detail the options provided by the Common Drive Controller for motor thermal protection.
- NOTE: For complete motor protection against sustained overloads or other operational issues, direct measurement of motor temperature using embedded thermostats and thermistors is required. This is detailed in the section below.

11.6.4.1 Motor I²T Function

- The common drive controller continuously monitors the motor current and performs a standard I²T (“I-Squared-T”) calculation to detect motor overload.
- The AEI modules are dual rated. They can operate with either a 110% overload or a 150% overload. The value set in parameter P99.02 selects the drive Full Load Current for the chosen rating as follows:
0 = (Disabled) 150% overload - for industrial plant applications.
1 = (Enabled) 110% overload - typically for fans and pumps. (This is the default value)
- The overload time has a default value of 60 seconds. This can be reduced or increased using parameter P2.07 and the range of values is from 10 s to 3600 s.

11.6.4.2 Motor Thermostat Protection

- Motor Thermostat protection is provided by connecting the motor thermostat to one of the digital inputs (DIGIN 1 to 6) on terminal block TB3 on the I/O Panel.
- The thermostat should be of the Normally Open contact type. The I/O module has solid state inputs therefore, no appreciable load is presented to the thermostat contacts. Connect this digital input to MTRIP, Control Flag 113 (P2.11).
- The motor thermostat input is normally held high (logic 1). In the event of the motor overheating the thermostat becomes open circuit (logic 0).
- P2.10 parameter controls the action of the drive when the MTRIP digital Input = (logic) 0.

- Options are:
 - 0 = No Action
 - 1 = Warning (No. 101)
 - 2 = Trip (No. 21)

11.6.4.3 Motor Thermistor Protection

- Connecting a motor Positive Temperature Coefficient (PTC) thermistor between TB5/1 and TB5/3 on the I/O Panel can provide motor PTC protection.
- There are several parameters withing the Common Drive Controller that configure the operation of the PTC input:
 - P2.13 - Motor PTC Trip Resistance
This is the value of motor PTC resistance to be determined as the trip level, i.e., above this value the motor is too hot; there is $\pm 0.1\text{k}\Omega$ hysteresis on this value.
Allowed range: 0.10k Ω to 10.00k Ω
 - P2.14 - Measured PTC Resistance
This is the value of resistance that the drive has determined between TB5/1 and TB5/3. Allowed range: 0.10k Ω to 10.00k Ω
 - P2.15 - Motor PTC Action
This parameter specifies the action to be taken by the drive when the measured PTC resistance is above the Trip value, i.e., when P2.14 > P2.13. Options are:
 - 0 = No Action (default)
 - 1 = Warning - drive issues a PTC Warning (No. 103)
 - 2 = Trip - drive issues a PTC Trip (No. 66)
 - 3 = Warning and Current Limit - drive issues a PTC Warning and additionally the current limit is reduced to the motor's capability at this speed.
- The motor PTC Trip is made auto-resettable by setting P28.10 (Motor Trips Auto-Reset Enable).

11.6.5 Grounding Requirements

- The AEI module will be grounded (earthed) by the metal contact when bolted in place on the cross rails of the enclosure.
- This contact must be tested using a current of at least 10A passed between the ground stud of the AEI module and the enclosure.
- The resistance must be $\leq 0.02\Omega$.
- If this cannot be achieved, then a separate cable must be fitted between the AEI modules ground stud and the main system ground.

11.6.6 Shrouding

- The PDS is designed to be operated with the enclosure doors closed and locked.
- As an additional safety measure to prevent accidental contact with live parts, shrouding is required inside the enclosure.
- The AEI module is provided with shrouding which *MUST* be fitted.
- Consideration should be given to other components within the enclosure such as rectifiers, reactor and filter terminals, etc. When designing and fitting shrouds, the material would normally be clear polycarbonate sheet of >2.0mm thickness and having a recognized flame retardancy rating.
- Shrouding should be designed so as not to restrict the air flows inside the enclosure. When using the AEI as a retrofit to existing systems, then the original shrouding must be re-fitted after fitting the AEI module/s.
- All shrouding should be fitted with electrical hazard warning signs/labels to alert personnel of danger:



Figure 11-12. Electrical Hazard sign

11.6.7 Other Safety/Protection Requirements

Control and Power Separation

- It is good practice to mount the low voltage components e.g., controller, I/O units, communications modules etc. in a segregated or separated part of the enclosure from the high-power rectifier/AEI modules.

Arc Containment

- The system designer should consider arc containment issues.
- In the event of a catastrophic failure of power components, arcing, flash energy and debris may be released.
- It is essential that this will not result in injury to personnel near to the enclosure.
- Such measures will include consideration of placement of ventilation louvres, roof mounted arc flaps which both absorb energy and enable pressure to be released safely.

Circuit Breakers

- Install a suitably rated circuit breaker on the incoming mains supply.

11.6.8 Specific Application Requirements to Comply with UL 61800-5-1

11.6.8.1 Branch Circuits

- The AEI output short circuit protection does not protect branch circuits. The UL standard states:
The integral solid state short circuit protection does not provide branch circuit protection. Branch circuit protection must be provided in accordance with the National Electrical Code and any additional local codes.

11.6.8.2 Motor Thermal Protection

- UL 61800-5-1 requires that motor over-temperature protection is provided by direct measurement of motor temperature.
- This must be provided by the system controller.
- Section 11.6.4 details how this is provided by the MV3000 Common Drive Controller.

11.6.9 Bonding

- Electromagnetic Compatibility (EMC) is a property of electrical/electronic equipment that allows it to operate in proximity to other electrical/electronic equipment without interfering with the other equipment.
- In a drive, control equipment can be adversely affected by the switching noise of the IGBTs.
- To reduce this interference low voltage components e.g., controller, I/O units, communications modules etc. should be mounted in a segregated or separated part of the enclosure from the high-power rectifier/AEI modules (normally separated by a grounded steel panel).
- In addition to the grounding (earthing) of metalwork for safety reasons, additional measures are needed to reduce the effects of electromagnetic noise. Cables used for safety grounding do not provide a low impedance path for high frequency noise signals due to the inductive impedance of the conductors. Therefore, bonding is required to ensure that all grounded metalwork is at the same potential with respect to these high frequency interference signals. Bonding is usually achieved via thin, wide sheets of metalwork fixed at multiple points between two units.
- The EMC linking plates provide equipotential, high frequency bonding between the AEI modules. This ensures that the 0 volts of each AEI is at the same potential and the effects of switching noise are minimized.
- This bonding also applies to all the cable gland plates to the enclosure. The screening effectiveness of screened or armored cables is achieved by bonding to the ground plate by a 360°-degree connection. This gland plate must then be connected directly to the enclosure walls.
- This bonding is required in addition to any electrical safety bonding and applies to both control and power cabling gland plates.

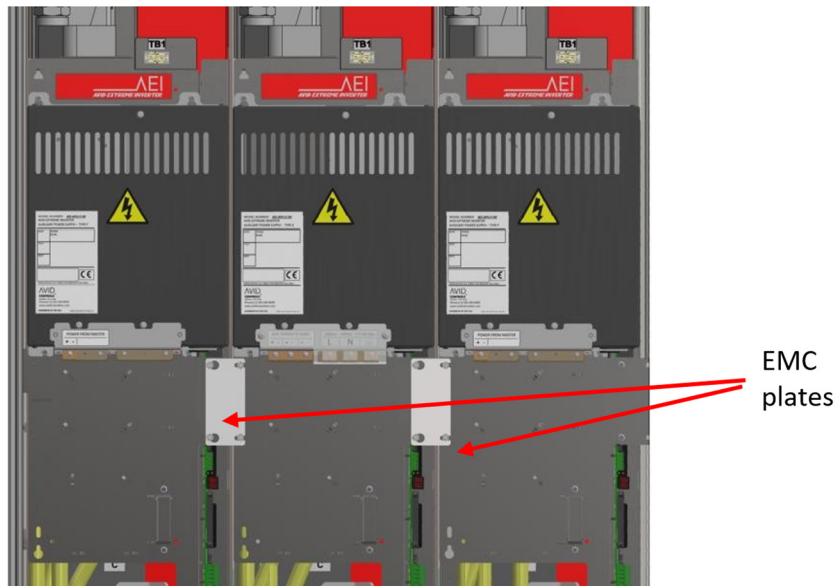

Figure 11-13. EMC linking plates

11.6.10 Shielded Control Ribbon Cables

- The control ribbon cables must be screened/shielded to prevent EMC interference.
- The cable should be routed below the APU units across the connected steel A and B phase shrouds.
- The screened ribbon should be secured via cable ties through the bridge punches on the metalwork.
- The screened ribbon cable should be secured at each end with a metal ribbon clamp ensuring that the clamp contacts the exposed copper braid of the ribbon cable.

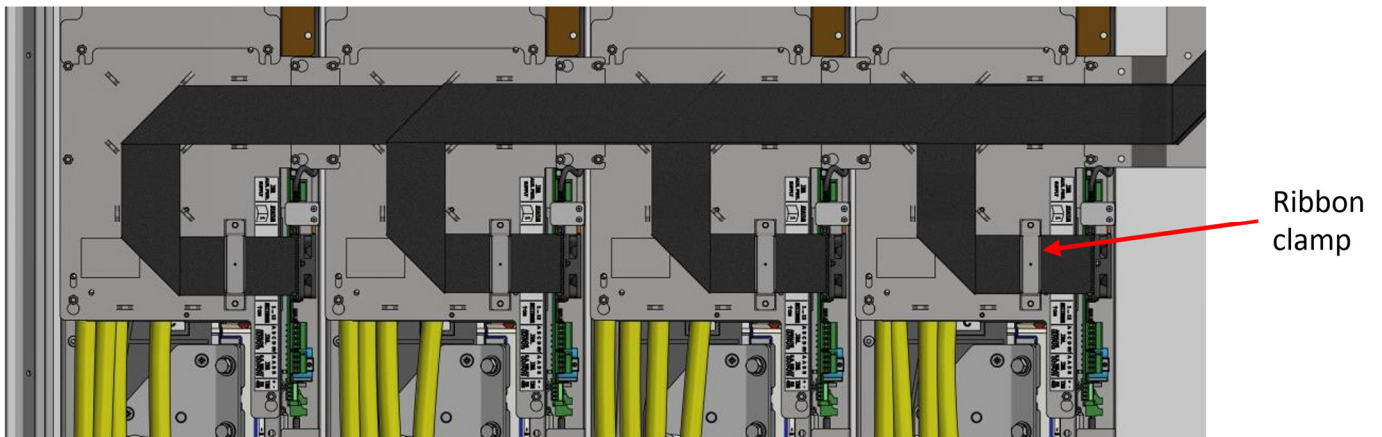

Figure 11-14. Routing of shielded ribbon cables

11.6.11 Cooling Fans

11.6.11.1 Capacitor Cooling

- AEI modules contain a DC link capacitor bank that must be provided with a suitable flow of cooling air.
- Some AEI modules have the capacitor cooling fans built into the unit, whereas some require an external supply of cooling air (see section 3.1 for details).
- Where capacitor cooling air is provided externally to the AEI modules, a minimum airflow of 260m³/h (150 CFM) with a maximum temperature of 50°C, is required per module.

11.6.11.2 Enclosure Cooling

- The air within the enclosure housing the AEI modules must be maintained at 50°C or below during operation.
- The cabinets will usually contain other heat-producing equipment (power supplies, coils, control modules etc.)
- Note that although ~90% of heat produced by the AEI is removed by the liquid cooling system, approximately 600W per AEI module will still be dissipated into the cabinet air.
- Therefore, suitable cooling fans are likely needed for the enclosure – the selection, quantity and location of these depends upon all of the heat being dissipated in the cabinet, combined with the external environmental conditions.
- If a completely sealed enclosure is required, other methods of removing heat, such liquid-liquid and liquid-air heat exchangers, will be required.